

Tolomatic Force Feedback Quick Setup Guide and Best Practice's

Setting up the Amplifier and Force Sensor:

The standard output connection is an M12, 8-pin, male, A-coded connector.

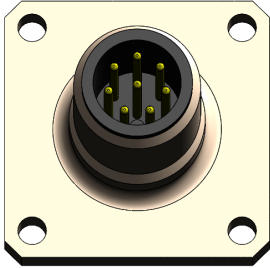

The eight pins have the following descriptions with explanations for each below.

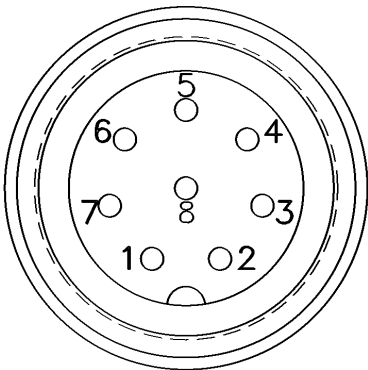

Pin	Function
1	0V - Ground Sensor
2	Range - High/Low
3	Reset / Measure Sensor
4	NC
5	0-10V Signal Out
6	I ² C Clock
7	I ² C Data
8	24VDC Power

Cable Recommendations:

A high quality shielded M12 cable is necessary to minimize noise during the welding process. The cable shielding must be grounded/connected on one end, preferably at the cabinet.

Pins:

Pin 1: Ground or 0V. Connect to common ground with actuator.

Pin 2: Apply 24VDC to Pin 2 to set the amplifier to the high range (**Suggested Setting**). This setting will allow for force measurement up to peak force of the actuator as shown on the actuator main label within the 0-10V output range of the amplifier. The ratio of the output voltage to force applied of the actuator alone is shown on the sticker near the M12 connector and labeled "FORCE OUTPUT SENSITIVITY".

Tolomatic ™		CE	C	UL	US	ServoWeld ™
ITEM#: 28010207	SERIAL#: J000360951-002	YYYYMMDD: 20241017				
CONFIG: CSWX3FV24W2F1CS1RX05S160A1UN1-FA-BBU						
MODEL: CSWX3	MOTOR: 3FV24W	SCREW: 5 mm/rev XR Roller				
CONT FORCE: 12.7 kN	PEAK FORCE: 18 kN	STROKE (mm): 160				
BUS VOLTAGE: 230 Vac, 3 Phase Ke: 77.6 v/kRPM L-L Peak POWER (kW): 4.92						
CONT. CUR. (Arms): 17.34 PEAK CUR. (Arms): 29 MAX SPEED (RPM): 4200						
RES (ohms): 1.14	INSUL. CLASS: F(155 °C)	PWM SOURCE: Voltage	IP: 65			
CUST#: 621-31164	FEEDBACK: F1-FANUC/AR128					
Phone: +1 763 478.8000 www.tolomatic.com MADE IN USA		Tolomatic Inc. Patented www.Tolomatic.com/Patents				

Tolomatic, Hamel, MN, USA
SERIAL NUMBER J00036095-02
FORCE OUTPUT SENSITIVITY 1905 N/V

If a lower range is desired, Pin 2 can be left open or set to ground (0V) and the output will be 1/10th of the “FORCE OUTPUT SENSITIVITY” label value. For example, with Pin 2 grounded and in low range, if the sensitivity label value is 1234N/V, the actuator output sensitivity will be 123.4N/V. The maximum output that can be used in this example is 123.4N/V x 10V or 1234N.

Pin 3: This pin is used to tare or reset the actuator output and set the amplifier in measure mode. The reset/tare functionality is critical to obtaining good measurements as sensor drift and/or actuator setup in the gun may apply a baseline load that must be zeroed so the measurement is only the weld force applied. When a measurement is needed, apply 24VDC for at least 1ms to Pin3 to reset/tare the output to 0V. Next create an open connection or ground connection on Pin3 to change to Measure mode. The time lag in the amplifier to change from the reset to measurement may be up to 20ms.

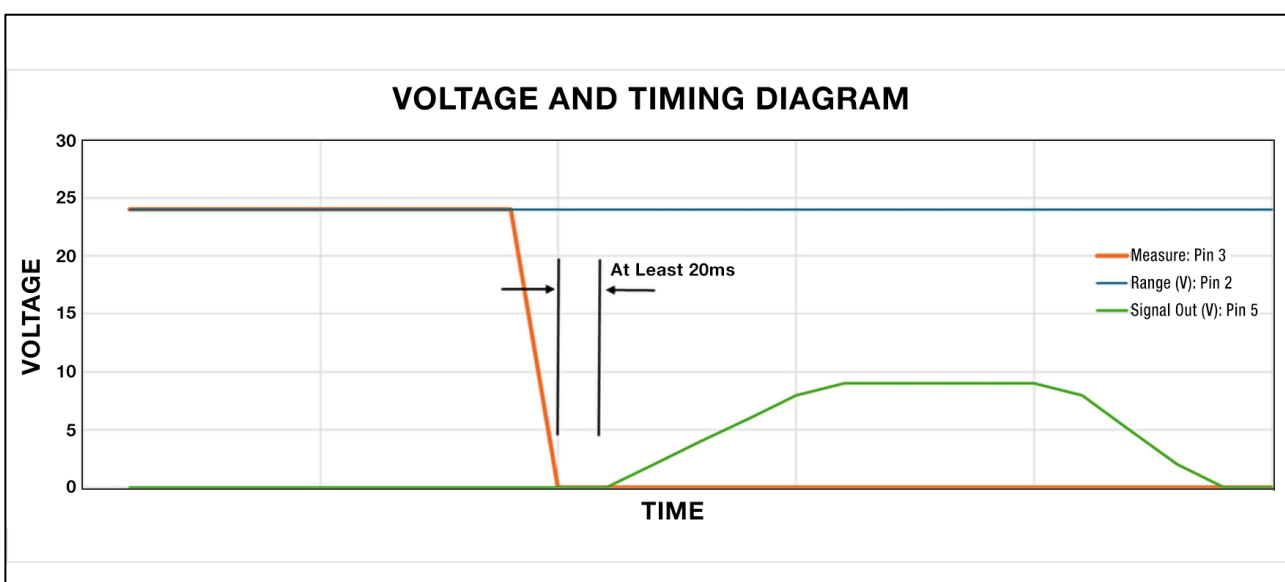

Pin 4: No Connection – Pin not used

Pin 5: Connect Pin 5 to read the 0-10VDC output. The force the actuator is sensing will be the “FORCE OUTPUT SENSITIVITY” value multiplied by this voltage. The force sensitivity value may change if the sensor in the actuator sees additional load when installed in the gun. This value should be confirmed after installation. During a press and hold move over 2 seconds the user may see the output voltage change. This is a function of the piezo sensor. Within a standard weld press cycle the drift will be minimal.

Pin 6: This pin is only used for amplifier setup and has no end user function.

Pin 7: This pin is only used for amplifier setup and has no end user function.

Pin 8: Amplifier power connection. Apply 24VDC to power the amplifier. The 24VDC amplifier power can also be tied to Pin 2 to set the range to the suggested value and simplify the wiring

Force Sensing with Ratio Weld Guns:

The force sensor will measure the force seen at the Tolomatic actuator and not the weld gun tips. In most cases, the weld controller needs the force *at the weld gun tips*, so a correction factor will need to be used if the weld gun has an arm ratio.

In this example below, the gun ratio is distanceX/distanceY,
i.e. $Tip\ Force = Actuator's\ Force * DistanceX/DistanceY$

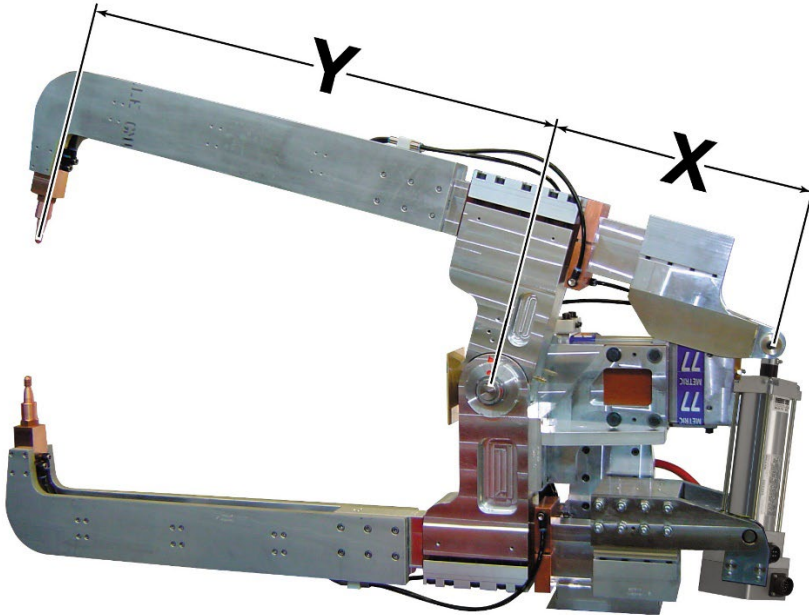

The Force Sensitivity sticker on the Tolomatic actuator in N/V is the force sensitivity of the actuator only, for example 1234 N/V. The controller for this case will need to be setup with a Sensitivity value of $1234 * X/Y$ Newtons per Volt to correctly output the force value at the weld gun tips.

Tolomatic, Inc.

Phone: (763) 478-8000; Toll Free: 1-800-328-2174; www.tolomatic.com