

Parts List (continued)

Item	Part No.	Description	3025-0001	3025-0101	3025-0201	3025-0002	3025-0102	3025-0202
14.	3025-1019	Small Flat Washer	4	4	4	4	4	4
15.	3005-1018	Caplug	1	1	1	1	1	1
16.	2307-1007	Hex Nut, 10-32	2	2	2	2	2	2
17.	3025-1040	Cap Screw, 10-32 x 1.38"				2	2	2
	3025-1028	Cap Screw, 10-32 x 1.125"	2	2	2			
18.	3025-1041	Cotter Pin, 1/8 x 3.50"				1	1	1
	3025-1029	Cotter Pin, 1/8 x 3.00"	1	1	1			
19.	0740-1002	Bleeder Valve, 1/8-27 NPT	4	4	4	4	4	4
20.	3025-9000	Retractor Body Subassembly	2	2	2	2	2	2
*21.	3010-1003	Flat Washer	2	2	2	2	2	2
*22.	3005-1004	Retaining Ring	2	2	2	2	2	2
*23.	3010-1001	Retractor Body	2	2	2	2	2	2
*24.	3010-1002	Belleville Spring Washer	2	2	2	2	2	2
25.	3025-1003	Inboard Housing	1	1	1	1	1	1
26.	3025-1001	Outboard Housing	1	1	1	1	1	1
27.	3025-1034	Soft Lining		2			2	
	3025-9008	Hard Lining Subassembly			2			2
28.	3025-1030	Housing Spacer (not shown)				2	2	2

* Part of Piston Retractor Subassembly 3025-9000

CAUTION: Wear adequate eye protection, gloves and clothing during installation. Brake fluid may cause eye irritation. In case of eye contact, flush with water for 20 minutes and get immediate medical attention.

INSTALLATION

Tighten mounting bolts to 20 foot-pounds. Install the Brake Linings (#27) and the Cotter Pin (#18). Fill the brake with fresh brake fluid from a sealed container. Connect the brake line to the 1/8-27 fitting. Use TEFLON® tape to seal the pipe threads.

Make certain the Brake Linings are installed BEFORE the brake is pressurized. Then, pressurize the brake and follow the bleeding instructions included in the parts sheet for the Airheart® master cylinder being used.

OVERHAUL

A special tool, which must be fabricated by the customer, is required to overhaul the 175 x 1 QCII brake. It should be made from a piece of flatstock steel, 1.50" long x .50" wide x .25" thick, with three holes drilled into it (see Figure 1). The two outer holes are to be .234" diameter and the central hole is to be big enough for 1/4-28 UNF tap through. Two #10-24 x 3/4" screws are required for the outer holes and a 1/4-28 x 2" screw with a minimum thread length of 1-1/8".

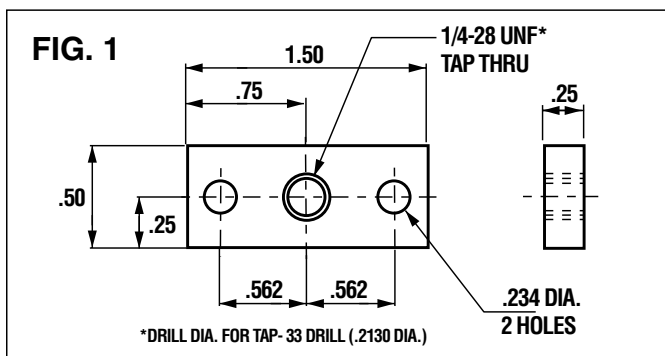

1. Remove the Cotter Pin (#18) and Brake Linings (#27).
2. Disconnect the brake line.
3. Remove the brake from the mounting bracket.
4. Remove the six bolts that hold the brake caliper halves together (#8, #9, #17).
5. Place a small ball bearing in the bottom bore of each Retractor Body Subassembly (#20) (see Figure 2).
6. Fasten the special disassembly tool to the piston with the two 10-24 x 3/4" screws. Then, screw the 1/4-28 x 2" screw into the disassembly tool. Turn the screw until the piston is extracted from the caliper.
7. Remove the Small Retaining Ring (#12) from the Piston (#1).
8. Remove the Drag Ring (#10).

9. Remove the Medium O-Ring (#6). Use a needle or O-Ring pick to remove the Large O-Ring (#5) from its groove on the Piston (#1). Be careful to avoid scratching the machined surfaces with sharp point. Remove Large Retaining Ring (#11) from the caliper. Remove the Retractor Body (#20), Wave Spring Washer (#4) (and shim, if one is found under the Wave Spring Washer).

NOTE: DO NOT disassemble the Retractor Body Subassembly (#20).

10. Clean all parts with solvent and either blow them completely dry with compressed air or allow sufficient time for them to completely air dry.
11. Examine all parts for wear or damage. Mating surfaces must be smooth and free of scoring, nicks, etc. Replace any parts that appear worn or damaged.

REASSEMBLY

All parts must be clean and dry. Be sure that all solvent has evaporated before reassembling, as the solvent will damage the O-Rings. Lubricate all of the parts with automotive brake fluid.

The following steps must be performed for each Piston:

1. Install the Medium O-Ring (#6) inside the Piston (#1). Install the Large O-Ring (#5) on the outside of the Piston (#1). Install the Small O-Ring (#7) in its groove on the Inboard (#25)

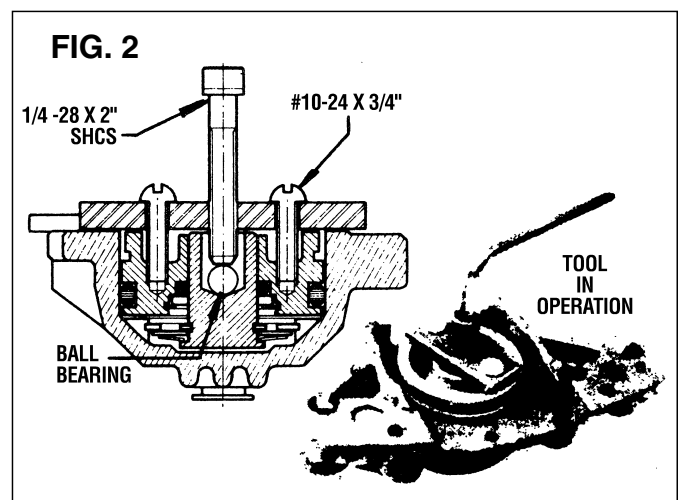

Housing half. (For spaced model, install second Small O-Ring in its groove on one of the Housing Spacers (#28).)

2. Place a Wave Spring Washer (#4) in the bottom of each piston bore. If a shim was found under the Wave Spring Washer during disassembly, it must be replaced in exactly the same position that it was found.
3. Place the Retractor Body Subassembly (#20) on top of the Wave Spring Washer.
4. Install the Large Retaining Ring (#11) in its recess.

- Lubricate Piston (#1), Large O-Ring (#5), Housing bore (#25, #26) and Retractor Body (#23) liberally with brake fluid.
- Place the Housing (#25 or #26) half in an arbor press with the bore facing up. Place Pilot Pin (P/N 3005-1045) in the bore of the Retractor Body Subassembly (#20) and place the Piston (#1) over the bullet nose of the Pilot Pin.
- Place the Housing (#25 or #26) half on an arbor press. Exercise care as the Piston (#1) is pressed into the bore of the caliper. Make sure the Piston is centered and square as it enters the bore of the caliper. Make certain the O-Ring (#5) on the Piston is not pinched as it enters the bore. Press the Piston down as far as it will go. When this is done, the Pilot Pin will be easy to remove. Use it to repeat this step with the other Piston and Housing half.

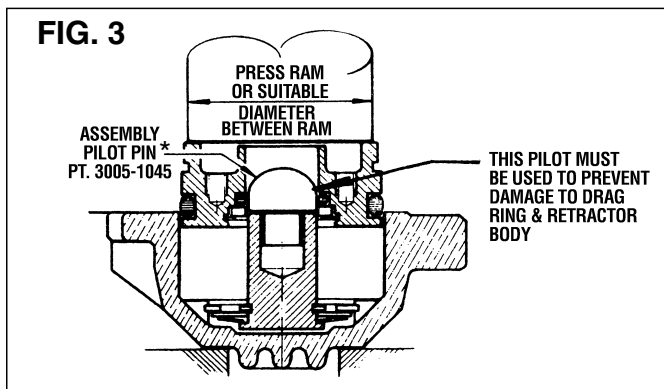

- Assemble the two Housing (#25, #26) halves together. Make sure to position the Small O-Ring (#7) properly in the fluid transfer passage between the two halves. Note that two Small O-Rings are used in the Spaced version of this brake. Hold the Housing halves (and Housing Spacer (#28) if spaced) firmly

together and install the six assembly bolts (#8, #9, #17) and their requisite nuts and washers. Note that the lock nuts are on the Outboard Housing (#26) half, opposite the Inboard (#25) half, with the 1/8-27 NPT inlet port. Use a torque wrench to tighten the bolts.

- Tighten the 1/4" bolts (#8) first, evenly in steps to 13 FOOT-POUNDS, MAXIMUM. Next, tighten the 5/16" bolts (#9), evenly in steps to 28 FOOT-POUNDS, MAXIMUM. Lastly, tighten the two Cap Screws (#17) evenly, in steps to 4 FOOT-POUNDS, MAXIMUM.

NOTE: Exceeding the torque figures above will distort the calipers. Insufficient torque will allow flexure and possible drag.

- Remount the caliper on the vehicle. Replace the Brake Linings (#27) and insert the Cotter Pin (#18) bending the long end to lock it in place.
- Fill the brake with fresh brake fluid from an unopened can. Reconnect the pressure line to the inlet port, using TEFLON® tape to seal the threads. DO NOT OVERTIGHTEN. The Piston Retractors will operate when the brake is pressurized.
- Bleed the brake following the bleeding instructions provided with the Airheart® master cylinder being used.

*NOTE: Pilot Pin 3005-1045 must be ordered separately from the Airheart® Brake Company.

Teflon® is a registered trademark of the E.I. DuPont de Nemours Co., www.dupont.com
Airheart®, A and heart symbols are registered trademarks of the Airheart® Brake Division of Tol-O-Matic, Inc.



TOL-O-MATIC, INC.

3800 County Road 116, Hamel, MN 55340

<http://www.Tolomatic.com> • Email: Help@Tolomatic.com

Phone: (763) 478-8000 • Fax: (763) 478-8080 • Toll Free: 1-800-328-2174



Information furnished is believed to be accurate and reliable. However, Tol-O-Matic assumes no responsibility for its use or for any errors that may appear in this document. Tol-O-Matic reserves the right to change the design or operation of the equipment described herein and any associated motion products without notice. Information in this document is subject to change without notice.