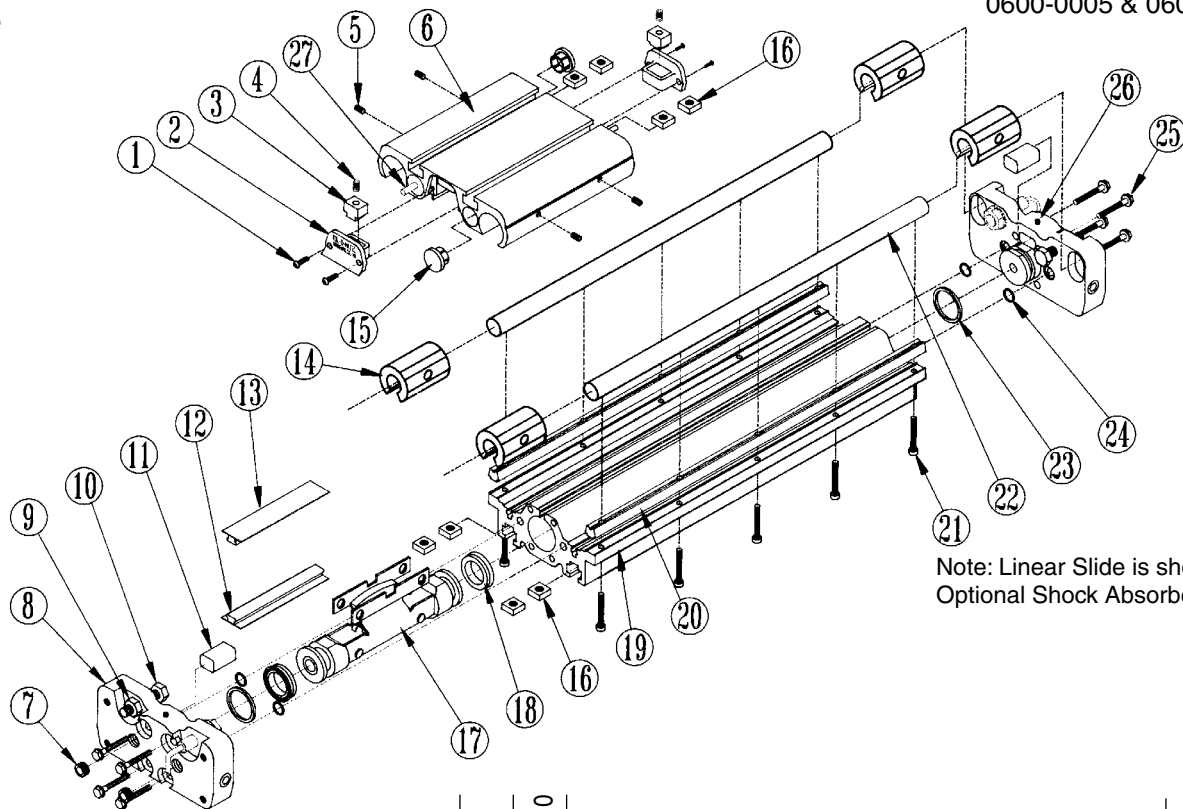

0600-4002_09

LS10 & LSMM10 Linear Slide

1" Bore

 Replaced Parts Sheets
 0600-0005 & 0600-0006

 Note: Linear Slide is shown with
 Optional Shock Absorbers

List of Parts

ITEM	PART NO.	DESCRIPTION	LS10	LSMM10
1 ¹	0910-1172	Screw	4	4
2 ¹	0610-1012	End Cap	2	2
3 ¹	4515-1012	Band Insert	2	2
4 ¹	4520-1012	Spring, Compression	2	2
5	0610-1046	Set Screw	4	4
6	0610-9000	Carriage Sub-Assembly	1	1
7 ²	1014-1065	Plug, Pipe	2	
	5910-1006	Pipe Plug		2
8	0610-9002	Head Sub-Assembly	2	
	5610-9002	Head Sub-Assembly		2
9 ²	0610-1026	Hex Nut	2	2
10 ²	0610-1016	Hex Head Screw	2	2
11	0610-1017	Band Wedge	2	2
12 ¹	0912-9006	Sealing Band (specify stroke)	1	1
3	0910-9016	Sealing Band (specify stroke)	**	**
13 ¹	0912-9000	Dust Band (specify stroke)	1	1
3	0910-9017	Dust Band (specify stroke)	**	**
14	0610-1005	Bearing, Linear	4	4
15	0610-1021	Hole Plug, Chrome	4	4

ITEM	PART NO.	DESCRIPTION	LS10	LSMM10
16	0610-1042	Square Nut	8	
	5610-1042	Square Nut		8
17	0910-9013	Piston Bracket Sub-Assembly	1	1
18 ¹	0910-1206	U-Cup	2	2
19 ⁴	RTBLS10	Tube (specify stroke)	A/R	A/R
5	0610-1220	Tube (specify stroke)	A/R	A/R
20 ⁶	RVRLS10	V-Block, Machined (spec. stroke)	2A/R	2A/R
7	0610-1037	V-Block, Machined (spec. stroke)	2A/R	2A/R
21	0610-1103	Cap Screw (Qty. depends on stroke)	A/R	A/R
22 ⁸	NGSLS10	Shaft, Machined (specify stroke)	2A/R	2A/R
9	0610-1032	Shaft, Machined (specify stroke)	2A/R	2A/R
23 ¹	0910-1160	O-Ring, Buna-N	2	2
24 ¹	0720-1003	O-Ring, Buna-N	4	4
25	0610-1011	Screw, Self-Tapping	8	8
26 ²	0915-1044	Set Screw	2	2
27 ¹⁰	0610-1100	Light Duty Shock Absorber	AR	AR
	0610-1101	Heavy Duty Shock Absorber	AR	AR

¹Included in Repair Kit RKLS10SK_ _ _

²Available only as Head Assembly 0610-9002 (5610-9002 metric).

³Narrower bands for models manufactured before 5-1-98 - Included in Repair Kit #0610-9033 SK_ _ _

⁴Replacement tube for LS manufactured after October 13, 2007 order with code RTBLS10 and specify stroke SK _ _ _ in inches

⁵Replacement tube for LS manufactured before October 13, 2007 order with no. 0610-1001 and specify stroke SK _ _ _ in inches

⁶Replacement V-Block for LS manufactured after October 13, 2007 order with code RVRLS10 and specify stroke SK _ _ _ in inches

⁷Replacement V-Block for LS manufactured before October 13, 2007 order with no. 0610-1037 and specify stroke SK _ _ _ in inches

⁸Replacement shaft for LS manufactured after October 13, 2007 order with code NGSLS10 and specify stroke SK _ _ _ in inches

⁹Replacement shaft for LS manufactured before October 13, 2007 order with no. 0610-1032 and specify stroke SK _ _ _ in inches

¹⁰Parts shown are shocks only. Field retrofit Kits are 0610-9022 Light Duty and 0610-9023 Heavy Duty.

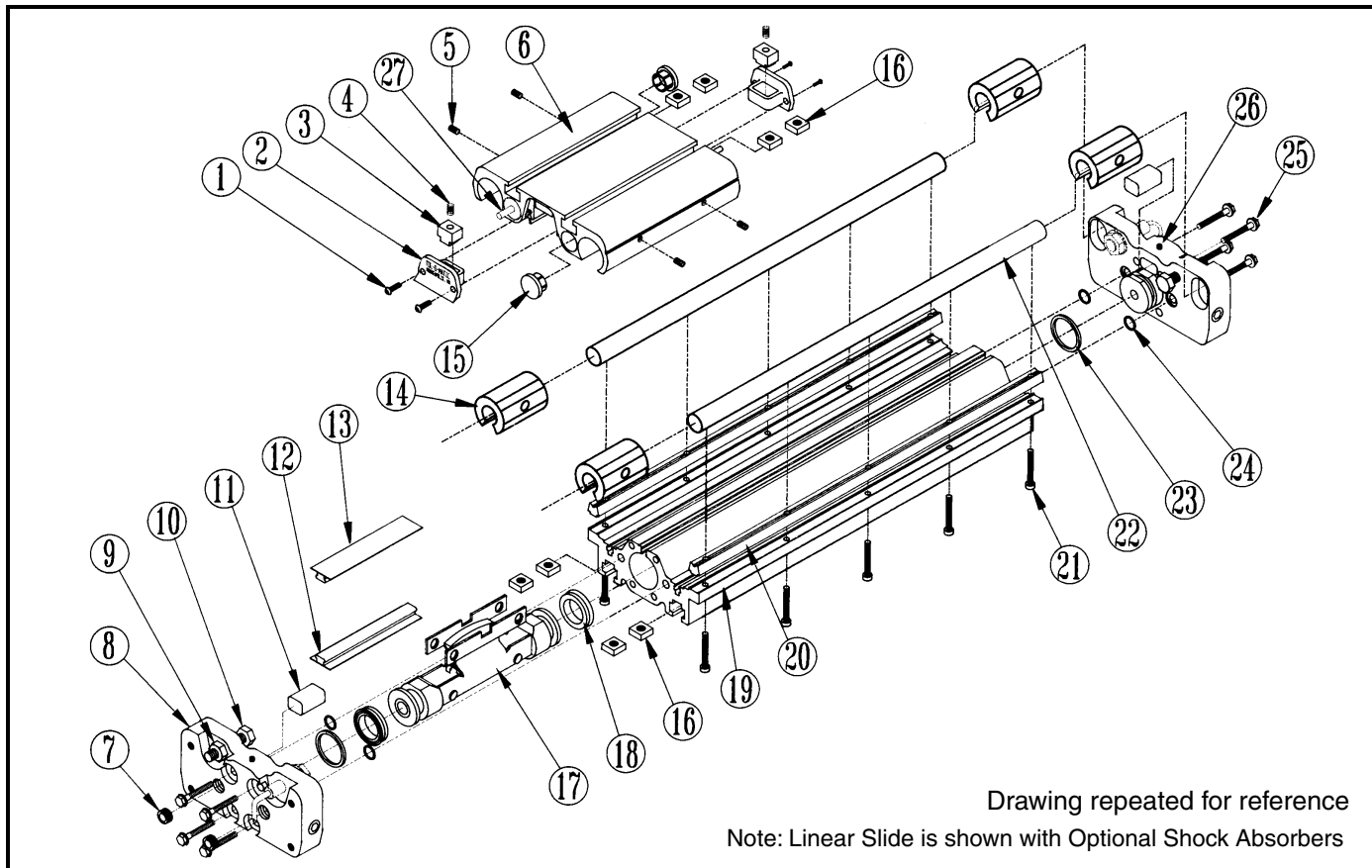

DISASSEMBLY

1. Remove Slide Cylinder from machinery.
2. Remove Screws (#1), and End Caps (#2). *Use care as End Caps (#2) are spring loaded.
3. Loosen set screws in Head Assemblies (#8).
4. Remove eight Screws (#25), and two Head Assemblies (#8).
5. Slide Piston/Bracket (#17) and Carrier (#6) out end of Tube/Base (#19).
6. Remove Screws (#5), and Bearings (#14), from Carrier (#6).
7. Remove Top Dust Band (#13).
8. Remove Inside Sealing Band (#12) by passing a screw driver or similar tool through the slot in the Tube/Base (#19) to dislodge the band. *Take care in doing this step to make certain that NO SCRATCHES ARE MADE in the Tube/Base (#19) bore or slot.

ASSEMBLY

1. Thoroughly clean all components, particularly the bore, slot, and bands. Carefully lubricate the tube and all rubber parts with MAGNALUBE®G.
2. Insert new sealing band (#12) into the Tube/Base (#19) bore (with the rubber portion facing up into the slot), centering the band along its entire length. *CAUTION: The metal edges of the band are very sharp. Exercise caution to avoid injury to yourself or the the Band and Tube/Base (#19) (When installing both the Inner and Top Bands).

3. Install the Piston/Bracket (#17), with new U-Cups (#18) in place in the Tube/Base by passing the Inner Sealing Band through the Piston/Bracket.
4. Push the Piston/Bracket (#17) along the cylinder length to position the Inner Band (#12) properly into the slot.
5. Cut Sealing Band (#12) to leave .5" overhang at either end of the Tube/Base. Remove rubber portion of overhanging band with a razor blade.
6. Install the Top Dust Band (#13) with the rubber sealing portion facing down into the slot and centering the band along its entire length. The band should lay over the center of the Piston/Bracket.
7. Cut Dust Band (#13) to leave .5" overhang at either end of the Tube/Base. Remove rubber portion of overhanging band with a razor blade.
8. Place two Bearings (#14) on each shaft (#22) with lowest set screw holes facing outward.
9. Install Carrier (#6) over Piston/Bracket (#17). Care must be taken to assure key in the bottom of the Carrier (#6) fits into the Piston/Bracket (#17) slot and one Bearing (#14) per Shaft (#22) is on either side of the Carrier (#6).
10. Push Bearings (#14) in Carrier (#6) as far as Carrier (#6) bores will permit.
11. Install Set Screws (#5). Apply **Loctite** #242 to Set Screws (#5) and screw them into Carrier (#6) until they bottom out on Bearings (#14), then back them out one half turn.
12. Install Springs (#4) and Band Inserts (#3) into End Caps (#2) and install in Carrier (#6) ends. Push Springs (#4) down to

- clear underside of Carrier (#6). Use Screws (#1) to hold End Cap (#2) in place.
13. Place Band Wedges (#11) between Bands (#12,#13) at both ends of cylinder.
 14. Install new O-Rings (#23,#24) on Head Assemblies (#8) and install Head Assemblies to cylinder. If using Square Nuts (#16) be sure they are installed in Tube/Base before Heads are installed.
 15. Install Screws (#25) and tighten Head Assemblies in place.
 16. Push Carrier (#6) to one end and tighten Set Screw in Head Assembly on that end. Push Carrier (#6) to the other end of the Slide Cylinder to take out any slack in Bands (#12,#13) and tighten Set Screw (#26) in Head Assemblies (#8).
 17. Run Carrier (#6) back and forth along the full stroke to make certain the Slide is properly assembled.
 18. Remount the completed Slide Cylinder.

SHAFT AND BEARING REPLACEMENT INSTRUCTIONS

Note: Shaft alignment is critical to assure proper function of the slide cylinder.

1. Remove Slide Cylinder from machinery.
2. Loosen two Set Screws (#26) in Head Assembly (#8) on one end of Cylinder.
3. Remove four screws (#25), and Head Assembly (#8) from same end of Cylinder.
4. Remove Screws (#21) from one shaft (#22).
5. Slide Shaft (#22) out of Carrier (#6).
6. Remove and replace Set Screws (#5) and Bearing (#14) from open side of Carrier (#6). Use **Loctite** #242 on Set Screws (#5) and screw them into Carrier (#6) until they bottom out on bearings (#14), then back them out one half turn.
7. Slide new Shaft (#22) through Bearings (#14). Replace Screws (#21) loosely, use **Loctite** #242 on Screws (#21).
8. Hold Top Dust Band (#13) at open end of Cylinder and slide Carrier (#6) to opposing end.
9. Tighten Screws (#21) below Carrier (#6) to 40 inch-pounds minimum.
10. To align Shaft (#22) properly, slide carrier over next Screw (#21) and tighten to 15 inch-pounds minimum. Repeat this until all Screws (#21) are tight.
11. Repeat steps 5 through 11 for second Shaft (#22).
12. Place Band Wedge (#11) between Bands (#12,#13) at open end of Cylinder.
13. Be sure O-rings are on Head Assembly (#8) and install Head Assembly (#8) to Cylinder. If using Square Nuts (#16) be sure they are installed in Tube/Base (#17) before Head is installed.
14. Install four Screws (#25) and tighten to 70-80 inch-pounds.
15. Position Carrier (#6) to the end of Cylinder with non-removed Head Assembly (#8). Push Carrier (#6) back to other end to remove any slack from Bands (#12,#13) and tighten Set Screws in Head Assembly (#8).
16. Run Carrier back and forth along the full stroke to make certain the Slide is properly assembled before applying air.
17. Remount the completed Slide Cylinder.

Loctite® is a registered trademark of the Loctite Corporation, www.loctite.com
 Magnalube®-G is a registered trademark of the Carleton-Stuart Corporation, www.magnalube-g.com
 Viton® is a registered trademark of the E.I. Du Pont de Nemours Co., www.dupont.com.

OPTIONAL ACCESSORIES

Shock Absorber (Shock absorbers are sold individually.)

DESCRIPTION		PART NO.
1"/25mm	Light Duty	0610-9022
1"/25mm	Heavy Duty	0610-9023

Inductive DC Proximity Sensors (also sold individually.)

DESCRIPTION		PART NO.
DC 10-24	NPN NO Sink	0610-1023
DC 10-24	PNP NO Source	0610-1024

NOTE: NO=Normally Open

SWITCH AND HARDWARE LISTING

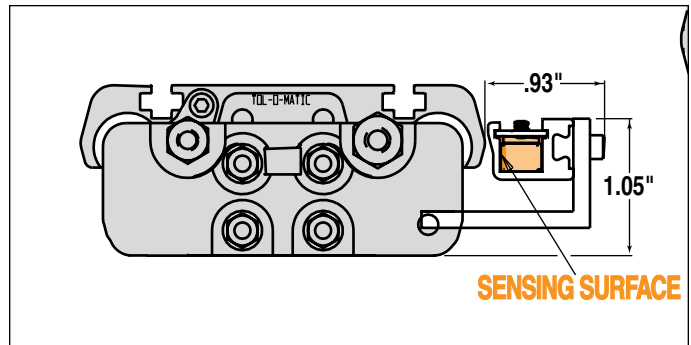

ITEM	PART NO.	DESCRIPTION	QTY
1.	3600-9082	Switch, Reed, Form A, 5M Wire	AR
	3600-9083	Switch, Reed, Form A, Male Connect	AR
	3600-9084	Switch, Reed, Form C, 5M Wire	AR
	3600-9085	Switch, Reed, Form C, Male Connect	AR
	3600-9086	Switch, Triac, 5M Wire	AR
	3600-9087	Switch, Triac, Male Connect	AR
	3600-9088	Switch, Hall, Sourcing, 5M	AR
	3600-9089	Switch, Hall, Sourcing, Male Connect	AR
	3600-9090	Switch, Hall, Sinking, 5M	AR
	3600-9091	Switch, Hall, Sinking, Male Connect	AR
2.	0610-9999	Hardware Only Kit	AR
3.	0610-9100	Rail and Rail Hardware (specify stroke)	AR

REED SWITCHES

NOTE: Form A Reed Switches should not be used in TTL logic circuits. A voltage drop caused by the L.E.D. indicator will result. For applications where TTL circuits are used, please contact the factory.

WARNING: An ohmmeter is recommended for testing Reed Switches. NEVER use an incandescent light bulb as a high current rush may damage the switch.

Reed and TRIAC switches are only recommended for signalling position, not directly powering solenoids. For shifting a solenoid, a relay or resistor is recommended between it and the Reed Switch. Switch ratings must not be exceeded at any time.

NOTE: The side of the switch with the groove indicates the sensing surface. This must face toward the magnet.

NOTE: For Hall Effect Switch Magnet, be sure the S pole of the magnet (indicated with black dot) is facing toward the switch (down).

UNIVERSAL SWITCH WIRING DIAGRAMS AND LABEL COLOR CODING

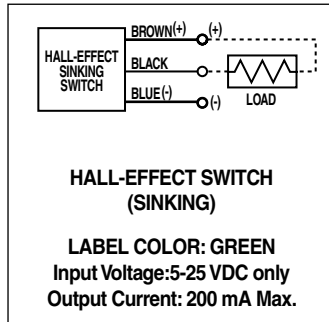
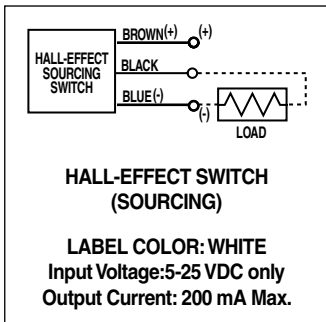
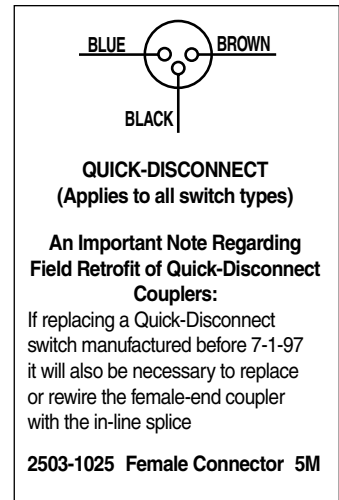
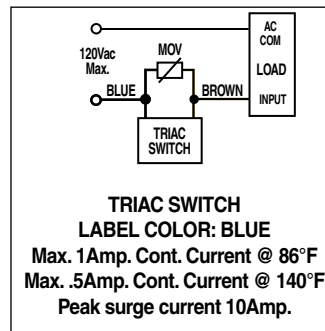
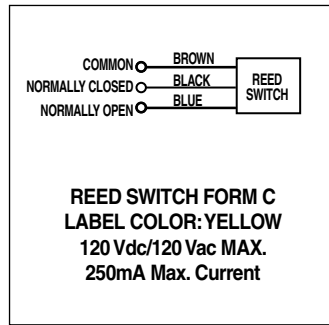
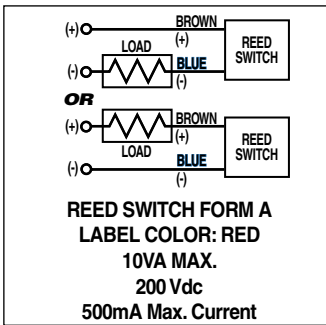

For complete Switch Performance Data, refer to the Tolomatic Fluid Power Catalog # 9900-4000.

TO ORDER RETROFIT KITS: SW (then the model number and base size, and code for type of switch needed).

EXAMPLE: SWLS10BT

Where **SW** is the switch kit, **LS** is Linear Slide, **10** is the 1" size, and **BT** is a Form C Reed Switch with 5-meter lead.

All Switch Kits come with 1 switch and mounting hardware.

SWITCH TYPE CODE

- BT** (Form C Reed Switch with 5-meter lead)
- BM** (Form C Reed Switch with 5-meter lead and QD)
- RT** (Form A Reed Switch with 5-meter lead)
- RM** (Form A Reed Switch with 5-meter lead and QD)
- CT** (TRIAC Switch with 5-meter lead)
- CM** (TRIAC Switch with 5-meter lead and QD)
- KT** (Hall-effect Switch (Sinking) 5-meter lead)
- KM** (Hall-effect Switch (Sinking) 5-meter lead and QD)
- TT** (Hall-effect Switch (Sourcing) 5-meter lead)
- TM** (Hall-effect Switch (Sourcing) 5-meter lead and QD)



3800 County Road 116, Hamel, MN 55340
<http://www.Tolomatic.com> • Email: Help@Tolomatic.com
 Phone: (763) 478-8000 • Fax: (763) 478-8080 • Toll Free: 1-800-328-2174



Information furnished is believed to be accurate and reliable. However, Tolomatic assumes no responsibility for its use or for any errors that may appear in this document. Tolomatic reserves the right to change the design or operation of the equipment described herein and any associated motion products without notice. Information in this document is subject to change without notice.