

MXB63S Solid Bearing, Belt-Drive Actuators

63mm (2-1/2 inch) Series

EXPLODED VIEW - MXB63S

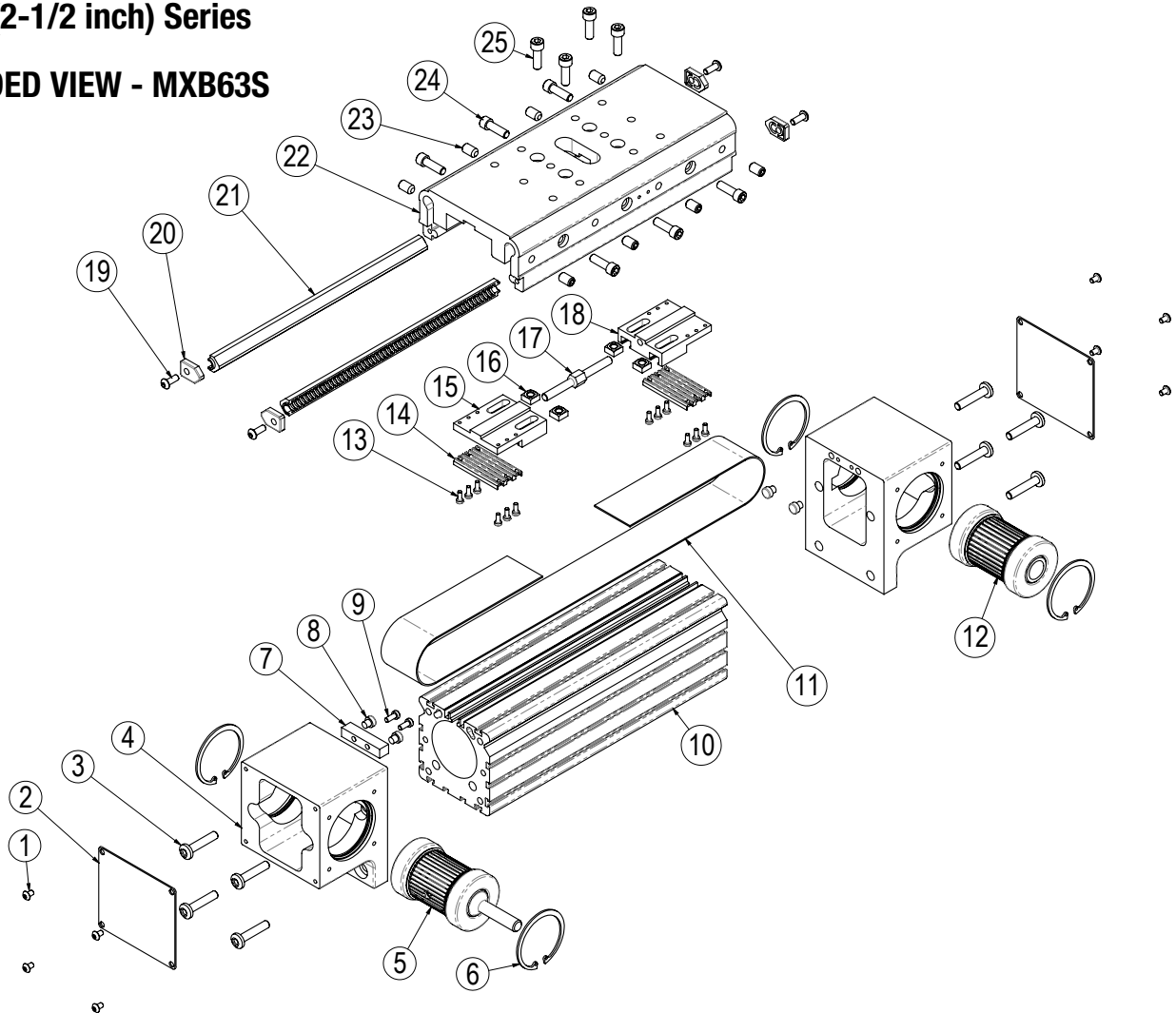

ITEM	PART NO or Config. Code	DESCRIPTION	QTY.
1	8540-1026	Button Head Cap Screw	8
2	8563-1020	End Cover Plate	2
3	8350-1023	Head Screws	8
4	8563-1000	Head	2
5	8630-9026	Drive Pulley Assembly	1
	8563-9027	Drive Pulley Assembly, Dual	1
6	8563-1026	Retaining Ring	4
7	8563-1032	Spacer	1
8	8525-1002	Bumper	4
9	3420-1644	Low Head Cap Screw	2
10*	RTBMXB63	Replacement Tube	1
11*	RBMXB63	Belt	1
12	8563-9028	Idle Pulley Assembly	1
13	8125-1070	Low Head Cap Screw	12
14	8563-1005	Belt Clamp, Bottom	2

ITEM	PART NO or Config. Code	DESCRIPTION	QTY.
15	8563-1004	Belt Clamp, LH	1
16	8563-1024	Square Nut	4
17	8540-1006	Turnbuckle	1
18	8563-1003	Belt Clamp, RH	1
19	2750-1049	Button Head Cap Screw	4
20	8163-1031	Bearing End Cap	4
21	8163-1030	Carrier Bearing	2
22	8563-1513	Carrier (inch)	1
	8563-1013	Carrier (metric)	1
23	8163-1572	Set Screw (inch)	8
	8163-1072	Set Screw (metric)	8
24	1009-1065	Socket Head Cap Screw (inch)	6
	8163-1071	Low Head Cap Screw (metric)	6
25	2164-1065	Socket Head Cap Screw	4

* Specify stroke length when ordering

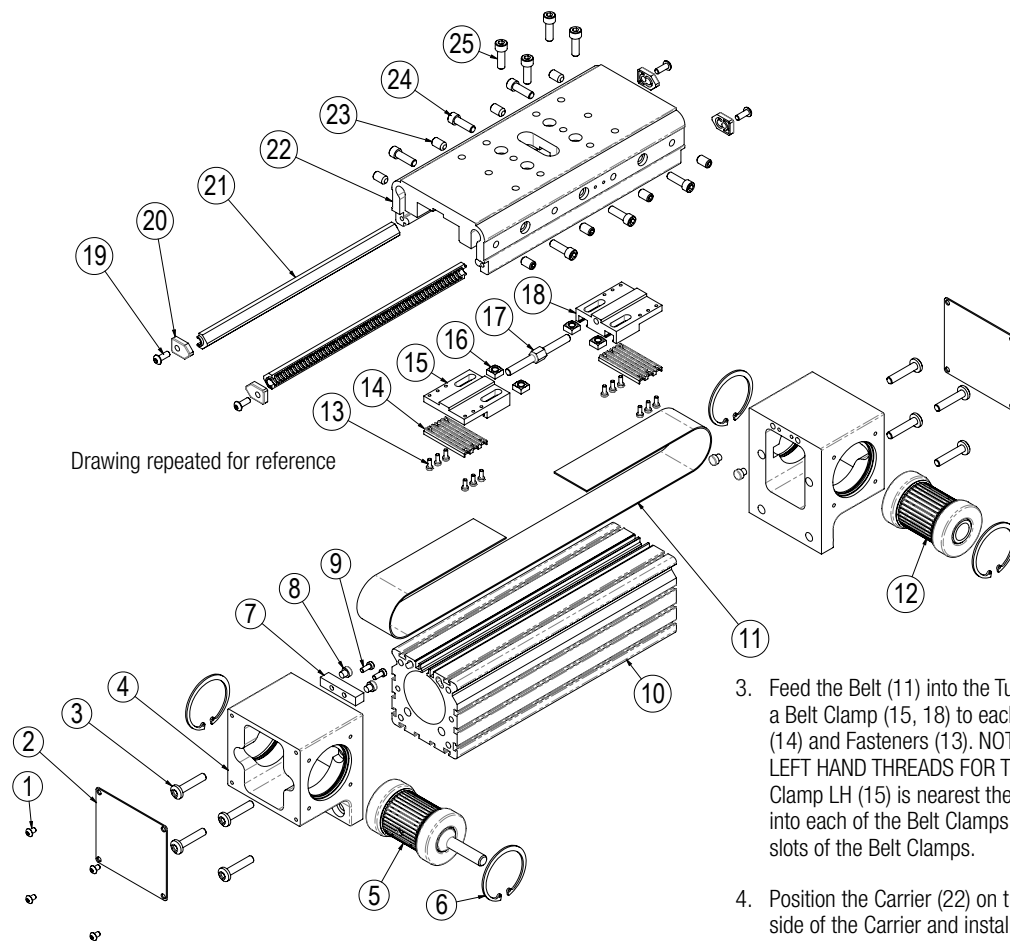

Drawing repeated for reference

GENERAL ACTUATOR DISASSEMBLY

1. Remove LHCS (25) from top of Carrier (22) to free it from the belt clamp assembly. Loosen the Turnbuckle (17) removing all belt tension. Slightly loosen the Carrier Tension Screws (24) and Set Screws (23). Remove Bearing End Caps (20) from the Bearings (21) and slide the Bearings out. The Carrier can now be removed.
 - a. Note: If the stroke of the actuator is too short to allow removal of the Carrier Bearings, it is necessary to remove the Non-Drive End Head (4) from the Tube (10).
2. Remove the Belt (11) from the Belt Clamps (15, 18) by removing Fasteners (13) and Belt Clamp Bottom (14). The Belt can now be removed from the actuator.
3. Remove the Retaining Rings (6) from each of the Heads (4). Note that the Bearing/Pulley Assemblies (5, 12) are slip fit into the Head (4), but are bonded in the bore w/ Loctite 641, so it may be necessary to press the Pulley Assemblies out of the Head.
4. Remove the Heads (4) from the Tube (10) by removing Fasteners (3).

GENERAL ACTUATOR ASSEMBLY

1. Install the Drive and Idle Heads (4) to the Tube (10). Note that the Bumper Spacer (7) installs onto the Drive End Head.
2. Install one Retaining Ring (6) into each Head (4). Apply a light coating of Loctite 641 to the OD of the bearings of the Pulley Assemblies (5, 12) and to the ID of the bearing bores of the Head. Install the Drive and Idle Pulley/Bearing Assemblies into the Heads.
 - a. NOTE THAT ORIENTATION OF THE DRIVE SHAFT IS DETERMINED BY THIS ASSEMBLY STEP. Install the remaining Retaining Ring into each Head.

3. Feed the Belt (11) into the Tube (10) from one end of the actuator. Install a Belt Clamp (15, 18) to each end of the Belt with Belt Clamp Bottoms (14) and Fasteners (13). NOTE THAT ONE BELT CLAMP (15) WILL HAVE LEFT HAND THREADS FOR THE TURNBUCKLE (17). Assemble so that Belt Clamp LH (15) is nearest the drive end Head. Start the Turnbuckle (17) into each of the Belt Clamps. Position Square Nuts (16) in their respective slots of the Belt Clamps.
4. Position the Carrier (22) on tube (10). Position the Bearings (21) on each side of the Carrier and install the Bearing End Caps (20). Snug SHCS (24) and Set Screws (23) then back off 1/8 turn to ensure they are not tight at this time.
5. **TENSION THE CARRIER.** The MX solid bearing carrier will provide best performance when properly adjusted. The carrier design contains both Tension (24) and Lock Screws (23). The Tension Screws control the amount of pressure placed on the Carrier Bearings. The Lock Screws lock the Tension Screws in place and provide fine adjustment of the Carrier Bearings (21).

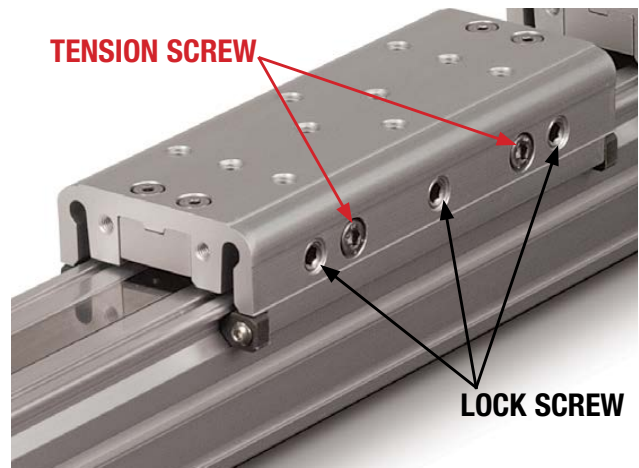

- a. Fully loosen all Tension (24) and Lock Screws (23) about 1/2 of a turn so that they are not engaged with the Bearing (21).
- b. Tighten Tension Screws (24) on both sides of the Carrier (22) roughly 1/8 to 1/4 turn clockwise past where the Screw starts to feel snug. The Carrier

should be very difficult or impossible to move by hand. If not, turn another 1/8 turn until it is difficult to move.

c. Next, adjust the Lock Screws (23) on both sides of the Carrier (22) roughly 1/8 to 1/4 turn clockwise past where the Screw starts to engage. The Carrier will be loose but should not rock sideways. To correct this, loosen the Lock Screws about 1/16 of a turn. If the Carrier becomes too snug, adjust the Lock Screws another 1/8 of a turn.

d. Ideal carrier tension is achieved when the Carrier (22) feels snug in relation to the Tube (10), yet can be moved by hand. No rocking motion should be present. The Carrier should also be loose enough to be moved by hand over the entire length of the actuator. If after this process the Carrier has become too loose, equally adjust all of the Lock Screws (23) with a slight 1/32 turn counter-clockwise. **During the service life of the application this process may need to be repeated. Keeping the Carrier in a properly adjusted tension will prolong the life of the MX bearing system and the actuator itself.**

e. When the proper carrier tension has been achieved, finish tightening the four Screws (19) to the Bearing End Caps (20).

f. Position the Carrier (22) over the belt clamps (15, 18) and install Fasteners (26), leaving looser at this time.

Allen wrench sizes for carrier adjustment, Solid bearing actuators

	Tension Screw		Lock Screw	
	mm	in	mm	in
63	5	1/4	5	3/16

6. TENSION THE BELT: To measure belt tension, position the edge of the Carrier (22) that is nearest the Head 6" from the inside edge of the Head (4) (either end of the actuator). Locate a force gage on the Belt (11) 2" from the inside edge of the Head. Support the tube side of the Carrier so that it is rigid to the Tube (10). Deflect the Belt 1/4" [6 mm] in either direction. The force gage should read between 18 and 22 lbs. [80 - 98 N]

7. Adjust the Turnbuckle (17) to achieve this tension, then tighten the Fasteners (25) to secure the Belt Clamps (15, 18) to the Carrier (22).

EXPLODED VIEW & PARTS LIST - LMI - INLINE MOTOR MOUNT

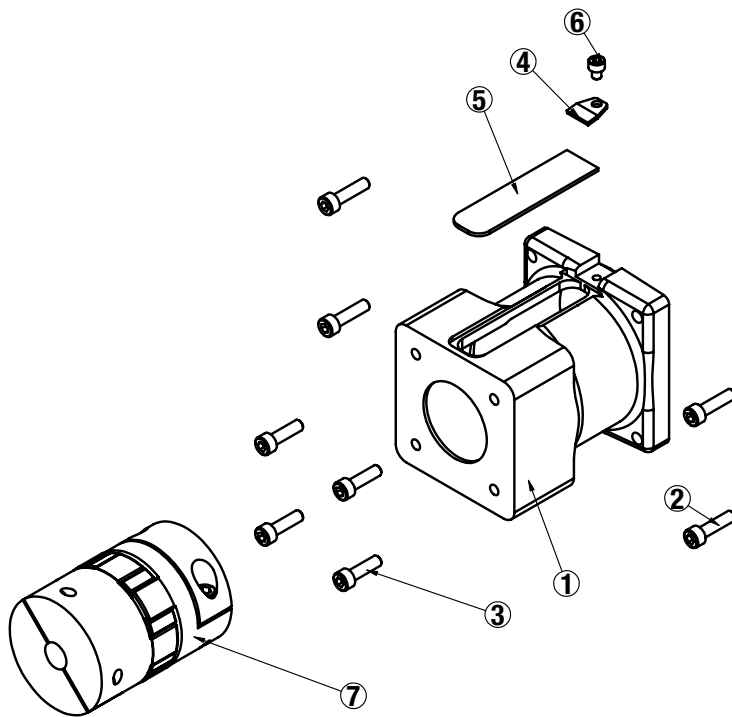

ITEM	PART NO.	DESCRIPTION	QTY.
1	§	Motor Spacer	1
2	2212-1098	Socket Head Cap Screws	4
3	§	Socket Head Cap Screws	4
4	1906-1022	Clamp	1
5	3410-1120	Cover	1
6	1124-1159	Socket Head Cap Screw	1
7	§	Coupler	1

§Determined by motor/gearhead used, contact Tolomatic

EXPLODED VIEW & PARTS LIST - RP - REVERSE PARALLEL MOTOR MOUNT

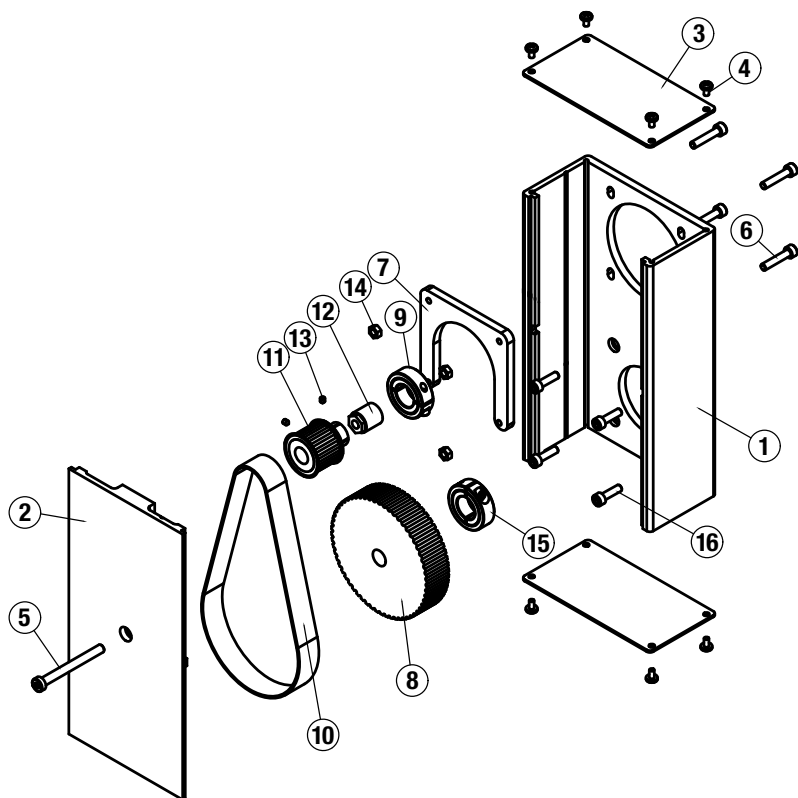

ITEM	PART NO.	DESCRIPTION	QTY.
1	§	Housing	1
2	§	Cover	1
3	3420-1602	Cap	2
4	0601-1625	Screw	8
5	3420-1641	Low Head Cap Screw	1
6	§	Socket Head Cap Screws	4
7	0602-1057	U-plate	
8	§	Pulley	1
9	§	Collar Clamp	
10	§	Belt	1
11	§	Pulley	1
12	0510-1111	Trantorque	
13	0610-1190	Set Screw	2
14	0603-2089	Nut	4
15	0520-1067	Collar Clamp	1
16	3420-1644	Low Head Cap Screws	4

§Determined by motor used, contact Tolomatic

PROCEDURE - MXB63S

REVERSE PARALLEL DISASSEMBLY INSTRUCTIONS:

1. Remove End Caps (3). Release tension on Belt (10) by breaking loose the Motor Fasteners (6).
2. Remove RP Cover (2).
3. Remove both Drive Pulley (11) and Driven Pulley (8) from their respective shafts. The Belt (10) will come off with the Pulleys.
4. Remove Motor Fasteners (6) from the U-Plate (7), to remove the motor from the Housing (1).
5. Remove the Housing (1) from the Head (page 1 #4) by removing Fasteners (16).

REVERSE PARALLEL ASSEMBLY INSTRUCTIONS:

*Apply Loctite #242 to all fasteners upon installation

1. Install Housing (1) to the Head (page 1 #4) with Cap Screws (16).
2. Install the Motor to the Housing (1) with Fasteners (6) into the U-Plate (7). Do not tighten the Fasteners at this time.
3. Locate the Belt (10) over the Pulleys (8, 11) and slide the Drive (11) and Driven (8) Pulleys over their respective shafts. Tighten each Pulley to its shaft with either Trantorque (12) or Collar Clamp (15). If Trantorque, use a torque wrench to apply appropriate torque. ½" hex on Trantorque apply 75 in-lbs. (8.5 N-m). 5/8" hex on Trantorque apply 100 in-lbs. (11.3 N-m).

4. Verify that there is clearance between the inside of the Housing (1) and each Pulley (8, 11). Verify that the Pulleys are aligned to each other.
5. Position the Cover (2) in mating slot of the Housing (1) and install the Fastener (5) to hold in place. Take care not to over-tighten. If the Cover is deflected it can interfere with the moving parts.
6. Tension the Belt (10) by pulling the motor away from the Drive Shaft Assembly (page 1 #5) with the appropriate force in the chart below. Tighten the Motor Fasteners (6) while this force is applied to the motor.

Smallest Shaft Diameter (Motor or Actuator)	Total Weight to Apply
mm	kg
4.572 to 6.579	5.902
6.604 to 12.675	9.988
12.7 to 15.875	14.074
15.875 and larger	18.160
<i>in</i>	<i>lb</i>
<i>0.18 to 0.259</i>	<i>13</i>
<i>0.260 to 0.499</i>	<i>22</i>
<i>0.500 to 0.625</i>	<i>31</i>
<i>0.625 and Larger</i>	<i>40</i>

7. Install both End Caps (3) with the Screws (4) to finalize assembly.

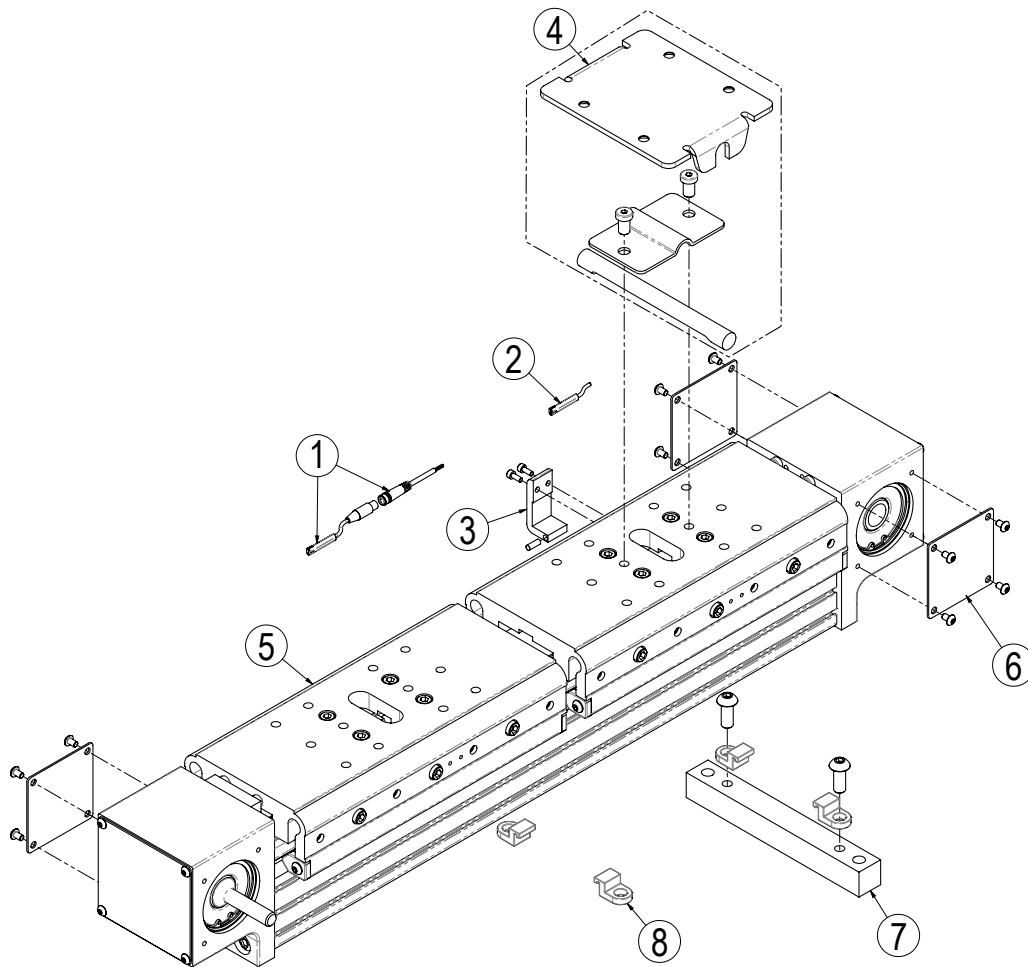

ITEM	Config. Code	DESCRIPTION
SWITCHES WITH QUICK-DISCONNECT COUPLERS		
1	SWMXB63SRK	Reed Switch, SPST Normally Open
	SWMXB63SNK	Reed Switch, SPST Normally Closed
	SWMXB63STK	Solid State Switch, PNP (Sourcing) Normally Open
	SWMXB63SKK	Solid State Switch, NPN (Sinking) Normally Open
	SWMXB63SPK	Solid State Switch, PNP (Sourcing) Normally Closed
	SWMXB63SHK	Solid State Switch, NPN (Sinking) Normally Closed
NOTE: Includes retained hardware & female connector for quick-disconnect		
SWITCHES WITHOUT QUICK-DISCONNECT COUPLERS		
2	SWMXB63SRY	Reed Switch, SPST Normally Open
	SWMXB63SNY	Reed Switch, SPST Normally Closed
	SWMXB63STY	Solid State Switch, PNP (Sourcing) Normally Open
	SWMXB63SKY	Solid State Switch, NPN (Sinking) Normally Open
	SWMXB63SPY	Solid State Switch, PNP (Sourcing) Normally Closed
	SWMXB63SHY	Solid State Switch, NPN (Sinking) Normally Closed

ITEM	PART NO	DESCRIPTION			
3	8563-9074	Magnet Kit			
		8563-1046	Magnet Block		
		2212-1092	Socket Head Cap Screw		
4	8163-9536	Floating Mount Kit (inch)			
		8163-9036	Floating Mount Kit (metric)		
		0925-1054	Floating Mount Clamp		
5	8563-9515	Auxiliary Carrier Assembly (inch)			
		8563-9015	Auxiliary Carrier Assembly (metric)		
		6	8540-9008	Side Cover Assembly	
				8540-1020	Cover Plate
				8540-1026	Button Head Cap Screw
7	8363-9016	Mounting Plate Kit			
		8363-1030	Mounting Plate		
		8163-1050	Tube Clamp		
		8363-1044	Button Head Cap Screw		
8	8163-9018	Tube Clamp Kit			
		8163-1050	Tube Clamp		

SWITCH WIRING DIAGRAMS AND LABEL COLOR CODING (CE and RoHS Compliant)

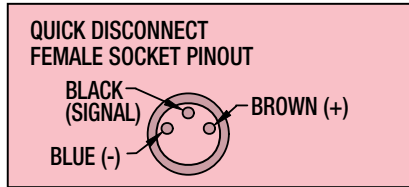
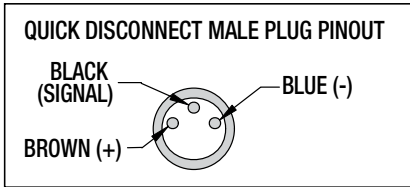
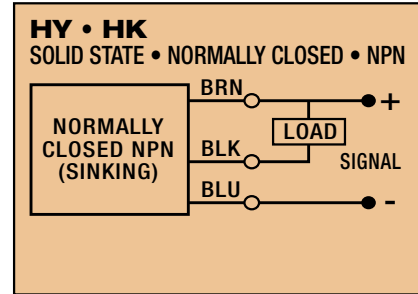
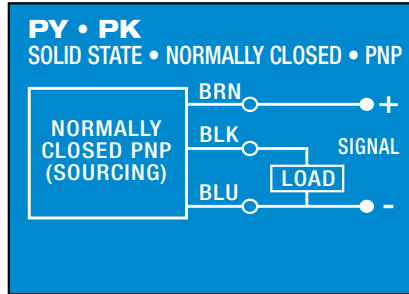
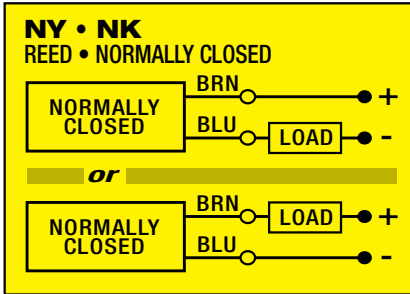
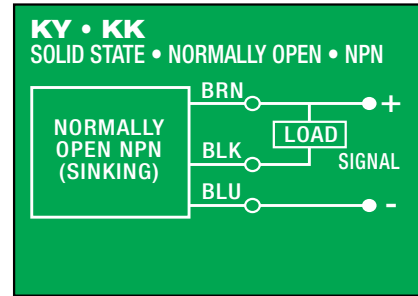
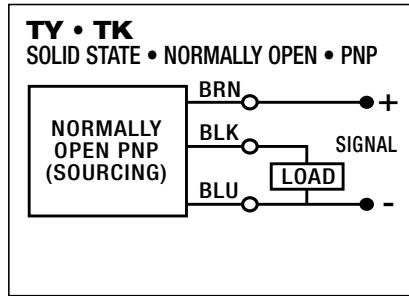
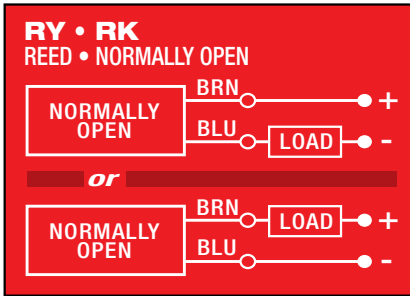

SWITCH INSTALLATION AND REPLACEMENT

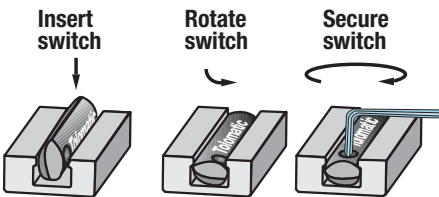

Place switch in side groove on tube at desired location with "Tolomatic" facing outward. While applying light pressure to the switch, rotate the switch halfway into the groove. Maintaining light pressure, rotate the switch in the opposite direction until the switch is fully inside the groove with "Tolomatic" visible. Re-position the switch to the exact location and lock it securely into place by tightening the screw on the switch.

SWITCH DETECTION POINT

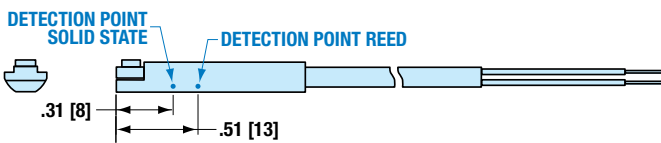

Dimensions in inches [brackets indicate dimensions in millimeters]



3800 County Road 116, Hamel, MN 55340 USA
 http://www.Tolomatic.com • Email: Help@Tolomatic.com
 Phone: (763) 478-8000 • Fax: (763) 478-8080 • Toll Free: 1-800-328-2174

COMPANY WITH
 QUALITY SYSTEM
 CERTIFIED BY DNV GL
 = ISO 9001 =

All brand and product names are trademarks or registered trademarks of their respective owners. Information in this document is believed accurate at time of printing. However, Tolomatic assumes no responsibility for its use or for any errors that may appear in this document. Tolomatic reserves the right to change the design or operation of the equipment described herein and any associated motion products without notice. Information in this document is subject to change without notice.