

MXB16S Solid Bearing, Belt-Drive Actuators

16mm (5/8 inch) Series

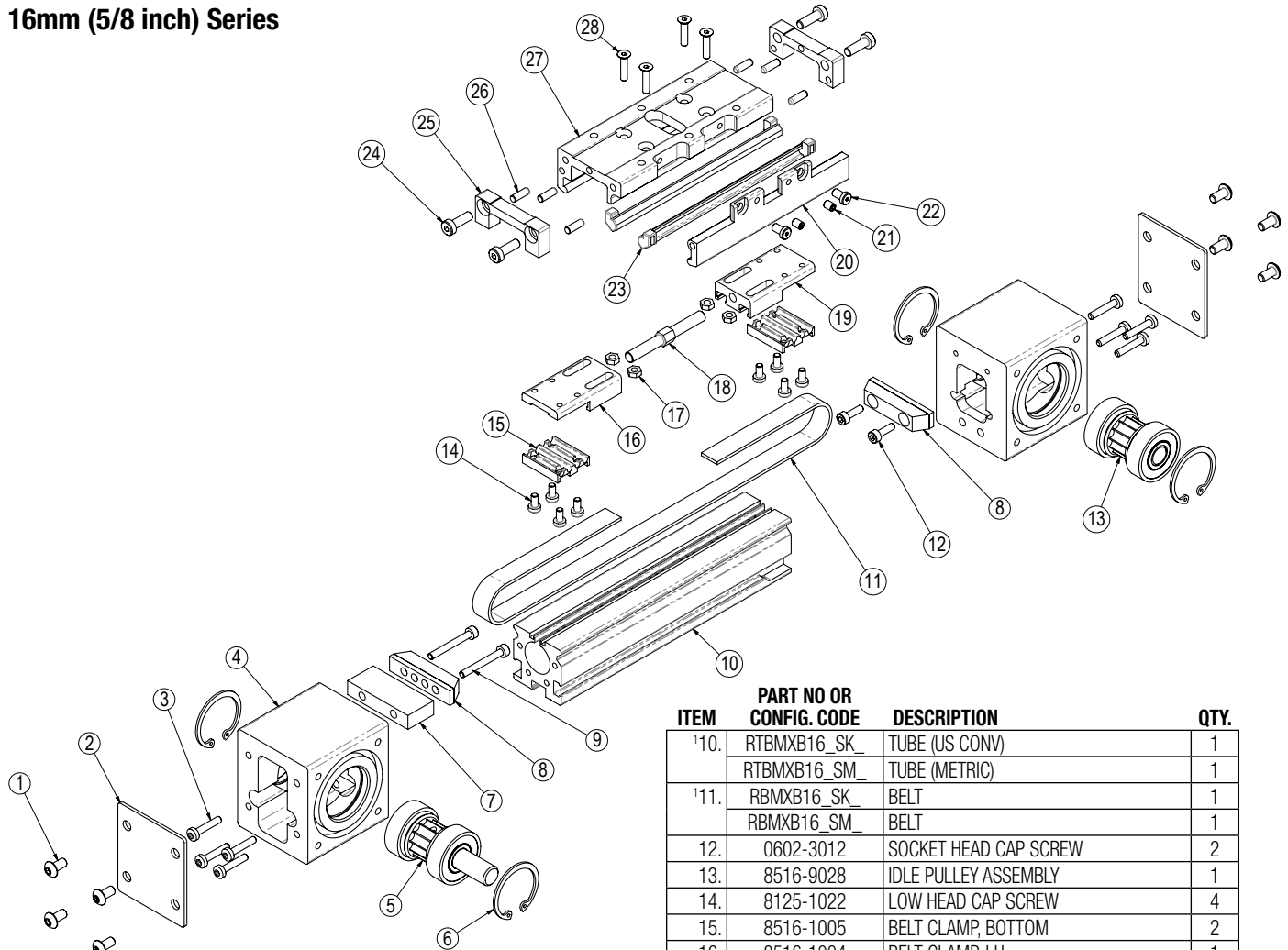

ITEM	PART NO OR CONFIG. CODE	DESCRIPTION	QTY.
1.	0510-1370	BUTTON HEAD CAP SCREW	8
2.	8516-1020	END COVER PLATE	2
3.	8316-1022	HEAD SCREWS	8
4.	8516-1047	HEAD	2
5.	8516-9025	DRIVE PULLEY ASSEMBLY, LMI	1
	8516-9026	DRIVE PULLEY ASSEMBLY, RP	1
	8516-9027	DRIVE PULLEY ASSEMBLY, RP DUAL	1
	8516-9029	DRIVE PULLEY ASSEMBLY, LMI DUAL	1
6.	2145-1031	RETAINING RING	4
7.	8516-1048	SPACER	1
8.	8516-9018	BUMPER	2
9.	2212-1091	SOCKET HEAD CAP SCREW	2

ITEM	PART NO OR CONFIG. CODE	DESCRIPTION	QTY.
10.	RTBMXB16_SK_	TUBE (US CONV)	1
	RTBMXB16_SM_	TUBE (METRIC)	1
11.	RBMXB16_SK_	BELT	1
	RBMXB16_SM_	BELT	1
12.	0602-3012	SOCKET HEAD CAP SCREW	2
13.	8516-9028	IDLE PULLEY ASSEMBLY	1
14.	8125-1022	LOW HEAD CAP SCREW	4
15.	8516-1005	BELT CLAMP, BOTTOM	2
16.	8516-1004	BELT CLAMP, LH	1
17.	0601-2089	HEX NUT	4
18.	8525-1006	TURNBUCKLE	1
19.	8516-1003	BELT CLAMP, RH	1
20.	8116-1514	CARRIER, LOWER (US CONV)	1
	8116-1014	CARRIER, LOWER (METRIC)	1
21.	8116-1575	SET SCREW (US CONV)	2
	8116-1075	SET SCREW (METRIC)	2
22.	8116-1515	LOW HEAD CAP SCREW (US CONV)	2
	8116-1076	LOW HEAD CAP SCREW (METRIC)	2
23.	8116-1030	CARRIER BEARING	2
24.	3410-3096	LOW HEAD CAP SCREW	4
25.	8516-1084	CARRIER END CAP	2
27.	8516-1513	CARRIER, UPPER (US CONV)	1
	8516-1113	CARRIER, UPPER (METRIC)	1
28.	8516-1085	FLAT HEAD CAP SCREW	4

¹ Replacement ordering method using config code: **MXB16S** **DC**

EXAMPLE: **RTB** **MXB16S** **BWS10SK** **21-25** **DC7**

Tube (RTB) or Belt (RB) | Model & Size | Bearing Style | Belt Size | Stroke Length | Aux. Carrier

Auxiliary Carrier Option Note: If replacing a Tube (10.) or Belt (11.) on an actuator that has an Auxiliary Carrier, add "DC ___" between Stroke Length and Motor Code. "DC" indicates the need for additional length and "___" indicates the measurement of space between carriers (in inches [SK] or millimeters [SM] as indicated earlier in the configuration string).

Drawing repeated for reference

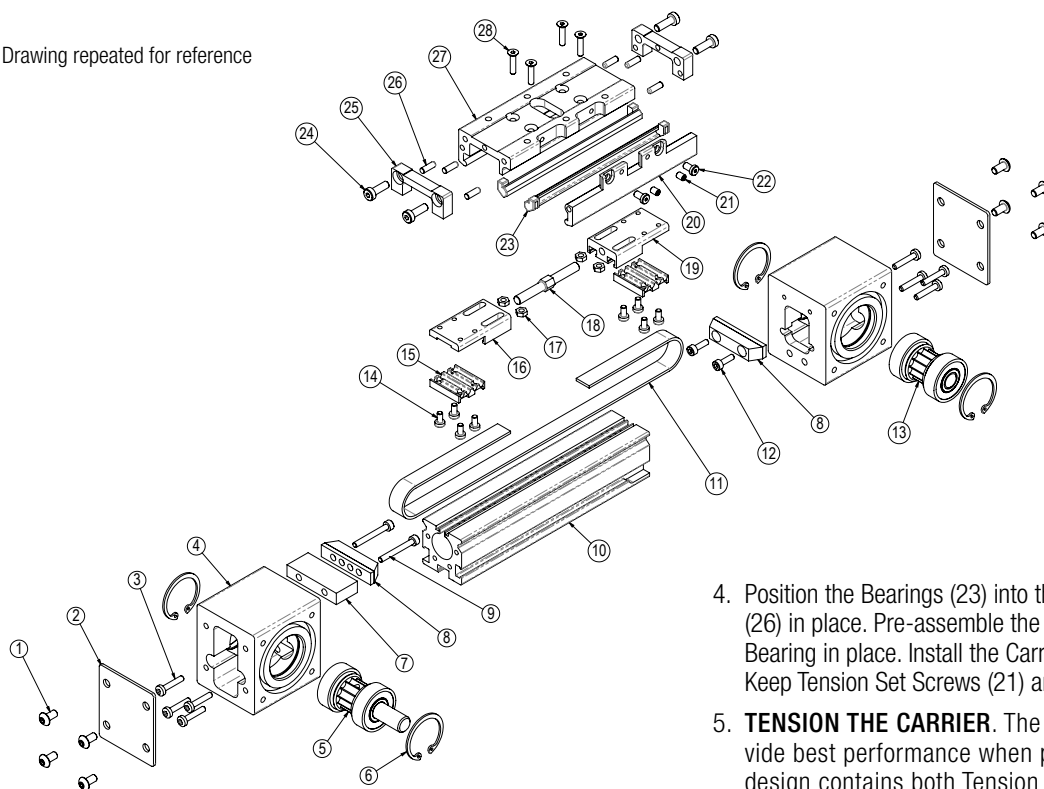

GENERAL ACTUATOR DISASSEMBLY

1. Remove FHCS (28) from top of carrier to free it from the belt clamp assembly. Loosen the Turnbuckle (18) removing all belt tension. Slightly loosen the Carrier Tension Screws (22) and Set Screws (21). Remove LHCS (24) and the carrier end caps (25). The carrier (27) can now be removed.
2. Remove the Belt (11) from the Belt Clamps (16, 19) by removing Fasteners (14) and Belt Clamp Bottom (15). The Belt can now be removed from the actuator.
3. Remove the Retaining Rings (6) from each of the Heads (4). Note that the Bearing/Pulley Assemblies (5, 13) are slip fit into the Head, but are bonded in the bore w/ Loctite 641, so it may be necessary to press the Pulley Assemblies out of the Head.
4. Remove the Heads (4) from the Tube (10) by removing Fasteners (3).

GENERAL ACTUATOR ASSEMBLY

1. Install the Drive and Idle Heads (4) to the Tube (10). Note that the Bumper Spacer (7) and Bumper (8) install onto the Drive End Head.
2. Install one Retaining Ring (6) into each Head. Apply a light coating of Loctite 641 to the OD of the bearings of the Pulley Assemblies (5) and to the ID of the bearing bores of the Head. Install the Drive and Idle Pulley/Bearing Assemblies into the Heads.
 - a. NOTE THAT ORIENTATION OF THE DRIVE SHAFT IS DETERMINED BY THIS ASSEMBLY STEP. Install the remaining Retaining Rings (6) into each Head.
3. Feed the Belt (11) into the Tube from one end of the actuator. Install a Belt Clamp (16, 19) to each end of the Belt with Belt Clamp Bottoms (15) and Fasteners (14). NOTE THAT ONE BELT CLAMP WILL HAVE LEFT HAND THREADS FOR THE TURNBUCKLE. Assemble so that Belt Clamp LH (16) is nearest the drive end Head. Start the Turnbuckle (18) into each of the Belt Clamps. Position Hex Nuts (17) in their respective slots of the belt clamps.

4. Position the Bearings (23) into the slots on the Carrier (27) with Pins (26) in place. Pre-assemble the Lower Carrier Plate (20) with the Bearing in place. Install the Carrier End Caps (25) with LHCS (24). Keep Tension Set Screws (21) and Lock Screws (22) loose.

5. **TENSION THE CARRIER.** The MX solid bearing carrier will provide best performance when properly adjusted. The carrier design contains both Tension and Lock Screws. The Tension Screws control the amount of pressure placed on the Carrier Bearings. The Lock Screws lock the Tension Screws in place and provide fine adjustment of the Carrier Bearings.

- a. Fully loosen all Tension (21) and Lock Screws (22) about ½ of a turn so that they are not engaged with the Bearing (23).
- b. Tighten Tension Screws (21) by turning them clockwise until the Carrier (27) is just tight enough so that no side-to-side rocking motion is present and it can easily be moved by hand over the entire stroke length with no hesitation. Very little torque on the screws is required to obtain this condition.

Note: The Tension Screws (21) are the small set screw style fastener. The Lock Screws (22) are the larger, low head, hex drive screws.

- c. Tighten Lock Screws (22) by turning them clockwise until tight. The Carrier (27) should feel snug in relation to the Tube (10), with no side-to-side rocking motion present. If the Carrier becomes too loose, loosen the Lock Screws, tighten the Tension Screws (21) and then re-tighten the Lock Screws.

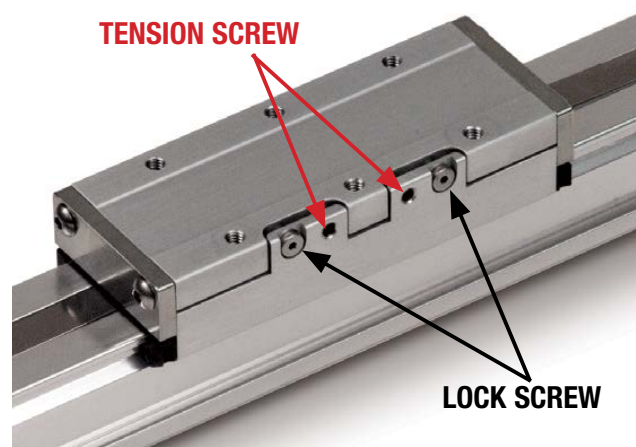

- d. Ideal carrier tension is achieved when the Carrier feels snug in relation to the Tube (10), yet can be moved by hand. No rocking motion should be present. The Carrier should also be loose enough to be moved by hand over the entire length of the actuator. If after this process the Carrier has become too loose, equally adjust all of the Lock Screws (22) with a slight 1/32 turn counter-clockwise. During the service life of the application this process may need to be repeated. Keeping the Carrier in a properly adjusted tension will prolong the life of the MX bearing system and the actuator itself.
 - e. When the proper carrier tension has been achieved, finish tightening the four Screws (24) to the Bearing End Caps (25).
 - f. Position the Carrier (27) over the Belt Clamps (16, 19) and install Fasteners (28), leaving looser at this time.
6. **TENSION THE BELT:** To measure belt tension, position the edge of the Carrier (27) that is nearest the Head (4) 6" from the inside edge of the Head (either end of the actuator). Locate a force gage on the Belt (11) 2" from the inside edge of the Head. Support the tube side of the Carrier so that it is rigid to the Tube (10). Deflect the Belt 1/4" [6 mm] in either direction. The force gage should read between 8 and 12 lbs. [35.6 - 53.4N]
 7. Adjust the Turnbuckle (18) to achieve this tension, then tighten the Fasteners (28) to secure the Belt Clamps (16, 19) to the Carrier (27).

ALLEN WRENCH SIZES FOR CARRIER ADJUSTMENT, SOLID BEARING ACTUATORS

	TENSION SCREW		LOCK SCREW	
	MM	IN	MM	IN
16	2	1/16	2	1/16

Direct Drive Motor Mounting Option

ITEM	PART NO.	DESCRIPTION	QTY
◊44.	CONFIGURED	MOTOR SPACER	1
◊45.	CONFIGURED	DOWEL PIN	2
◊46.	CONFIGURED	SCREW	4
◊47.	CONFIGURED	SCREW	4
◊48.	CONFIGURED	COVER	1
◊49.	CONFIGURED	CLAMP	1
◊50.	CONFIGURED	SCREW	1
◊51.	CONFIGURED	COUPLER	1

◊ Part number varies depending on YMH (Your Motor Here). Contact help@tolomatic.com for replacement part number.

A replacement Motor Mount Kit contains all parts listed above.

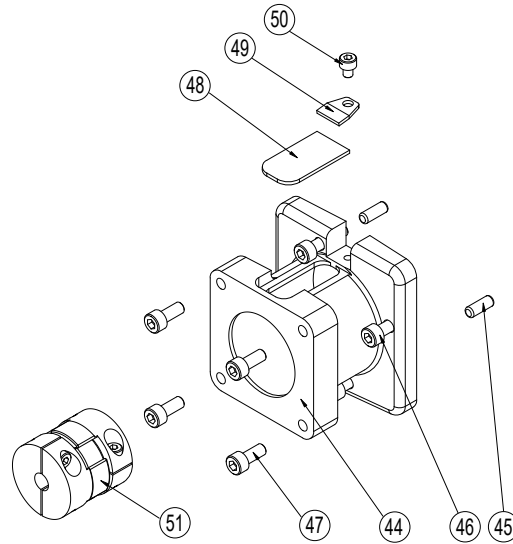

Replacement Motor Mount Kits ordering method: **MMK MXB16S** **YMH**

EXAMPLE: MMK MXB16S SDI YMHOTBD0

Motor Mount Kit ——— Model & Size ——— Bearing Style ——— Mounting Style ——— Motor Code

Reverse Parallel Reduction Drive Option

3:1 Reduction Drive

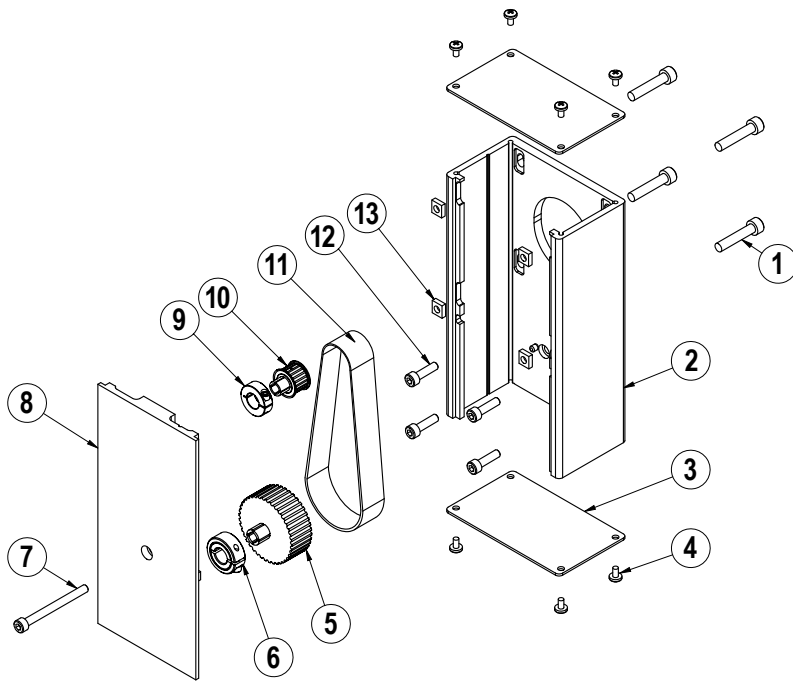

ITEM	PART NO.	DESCRIPTION	QTY.
◊1.	CONFIGURED	MOTOR FASTENER	4
◊2.	CONFIGURED	RP HOUSING	1
◊3.	CONFIGURED	RP HOUSING END CAP	2
◊4.	CONFIGURED	END CAP SCREW	8
◊5.	CONFIGURED	DRIVE SHAFT PULLEY	1
◊6.	CONFIGURED	COLLAR CLAMP, DRIVE SHAFT	1
◊7.	CONFIGURED	RP COVER FASTENER	1
◊8.	CONFIGURED	RP COVER	1
◊9.	CONFIGURED	COLLAR CLAMP, MOTOR	1
◊10.	CONFIGURED	MOTOR PULLEY	1
◊11.	CONFIGURED	BELT	1
◊12.	CONFIGURED	RP PLATE FASTENER	4
◊13.	CONFIGURED	SQUARE NUT	4

◊ Part numbers varies depending on YMH (Your Motor Here).
Contact help@tolomatic.com for replacement part numbers.

Disassembly Instructions

1. Remove End Caps (3), and release the tension on the Belt (11) by breaking loose the motor fasteners (1).
2. Remove the RP Cover (8).
3. The Belt (11) can now be removed along with the Motor.
4. Remove both Pulleys (10) and (5) from their respective shafts.
5. Remove the RP Housing (2) from the actuator head by removing the Fasteners (12).

Assembly Instructions

Note: Apply Loctite #242 to all fasteners upon installation

1. Install RP Housing (2) onto the actuator Head with Fasteners (12).
Note: If the RP housing has a bearing in it do not fully tighten the fasteners at this time. Instead temporarily install the RP cover (8) onto the RP case, positioning the bearing over the leadscrew shaft. Hold the cover in place while tightening all the Fasteners (12) so that the case is snug. Then remove the RP cover and finish tightening the fasteners
2. Install the Motor to the RP Housing with Fasteners (1) and Square Nuts (13). Do not tighten the fasteners at this time.
3. Locate the Belt (11) over the Pulleys (10) and (5) and slide both pulleys over their respective shafts. Tighten each pulley to its shaft with the Collar Clamps (9) and (6).

4. Tension the Belt (11) by pulling the motor away from the drive shaft with the appropriate tension force shown in the chart below. While tensioning, the actuator should be positioned so the weight of the motor does not affect the belt tension. Tighten the Motor Fasteners (1) while the tensioning force is applied to the motor.

SMALLEST SHAFT DIAMETER (Motor or Actuator)		TOTAL WEIGHT TO APPLY	
Inches	mm	lbs	kgs
0.18 to 0.259	4.572 to 6.579	13	5.902
0.260 to 0.499	6.604 to 12.675	22	9.988
0.500 to 0.625	12.7 to 15.875	31	14.074
0.625 and larger	15.875 and larger	40	18.160

Additional tips are found in Tolomatic [Electric Actuator Motor Mounts Technical Note # 3600-4203](#).

5. Verify that there is clearance between the inside of the RP case and each pulley. Verify the pulleys are aligned to each other.
6. Position the Cover (8) in the mating slot of the RP case and install the Fasteners (7) to hold it in place. Take care not to overtighten. If the cover is deflected, it can interfere with the leadscrew.
7. Install both End Caps (3) with the Screws (4) to finalize the assembly.

Switch Wiring Diagrams and Label Color Coding (Ce and Rohs Compliant)

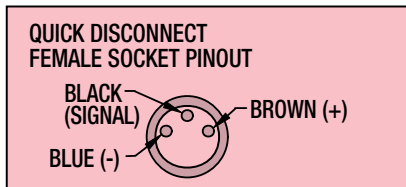
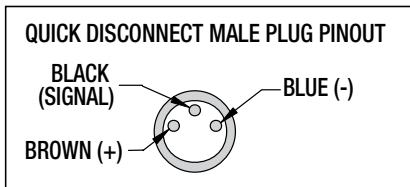
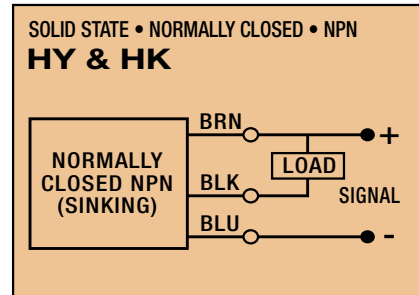
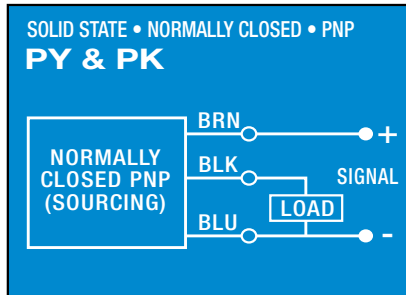
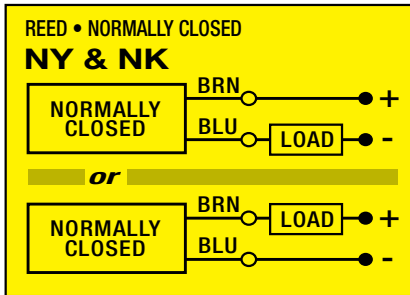
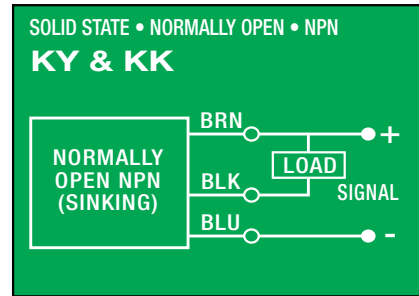
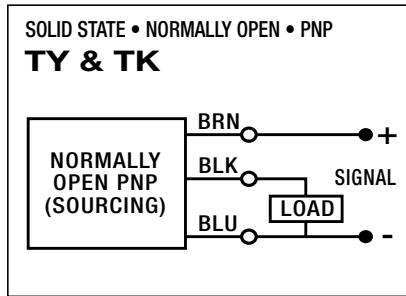
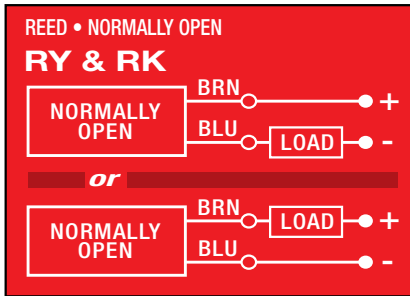

- Switches for MX:
- Include retained mounting hardware
 - In slot, sit below extrusion profile
 - Same for all sizes and bearing styles

Switch installation and replacement

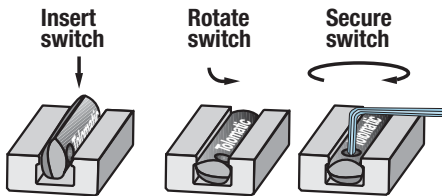

Place switch in side groove on tube at desired location with "Tolomatic" facing outward. While applying light pressure to the switch, rotate it such that the switch is halfway in the groove. Maintaining light pressure, rotate the switch in the opposite direction until the switch is fully inside the groove with "Tolomatic" visible. Re-position the switch to the exact location and lock the switch securely into place by tightening the screw on the switch.

Switch Detection point

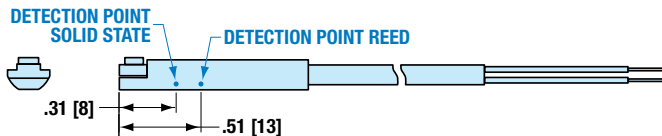

Dimensions in inches [brackets indicate dimensions in millimeters]



3800 County Road 116, Hamel, MN 55340 USA
<http://www.Tolomatic.com> • Email: Help@Tolomatic.com
 Phone: (763) 478-8000 • Fax: (763) 478-8080 • Toll Free: 1-800-328-2174

COMPANY WITH
 QUALITY SYSTEM
 CERTIFIED BY DNV
 = ISO 9001 =

All brand and product names are trademarks or registered trademarks of their respective owners. Information in this document is believed accurate at time of printing. However, Tolomatic assumes no responsibility for its use or for any errors that may appear in this document. Tolomatic reserves the right to change the design or operation of the equipment described herein and any associated motion products without notice. Information in this document is subject to change without notice.