

MXB63U Unguided, Belt-Drive Actuators

63mm (2-1/2 inch) Series

Models: MXB63UBWS50

EXPLODED VIEW - MXB63U

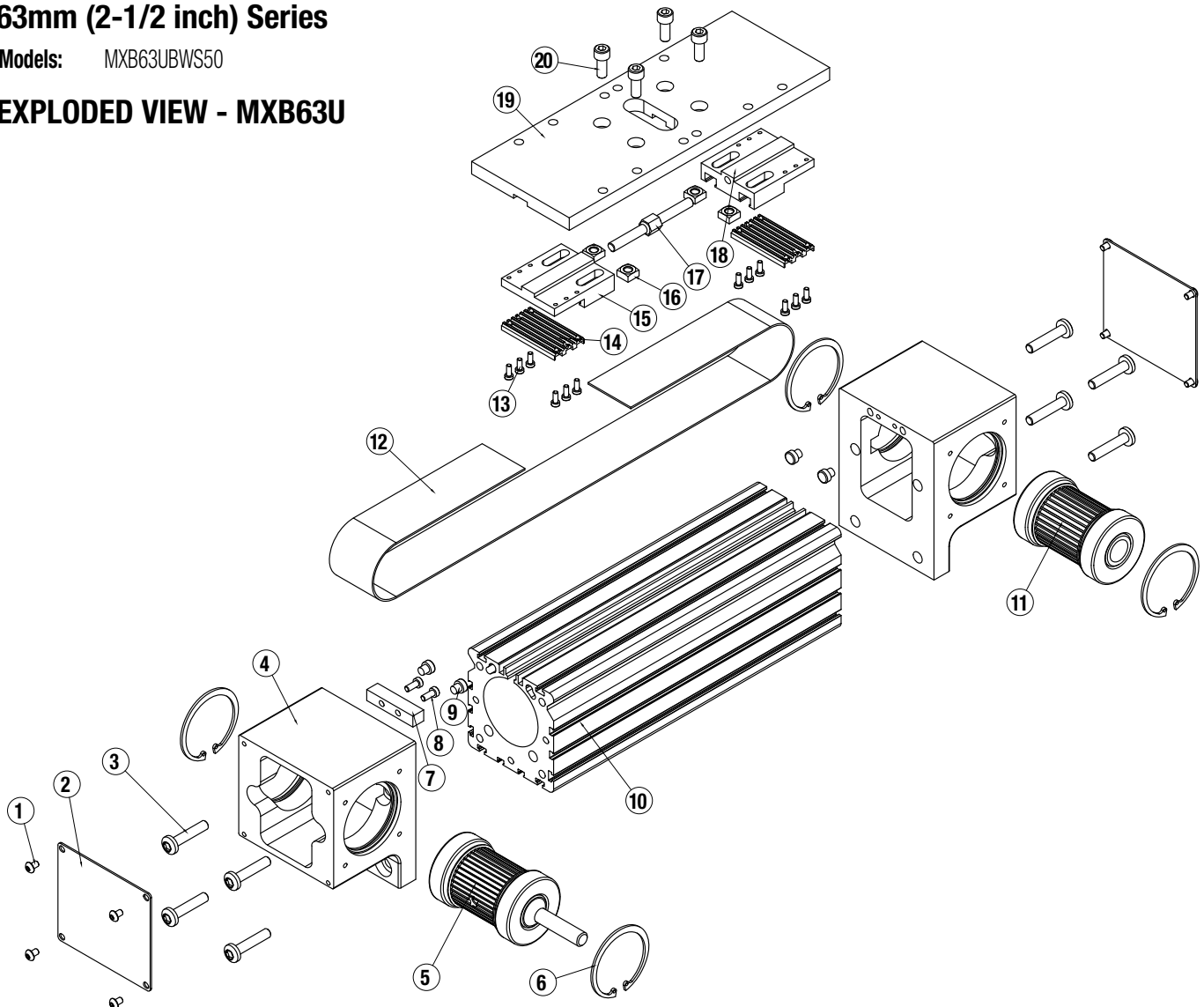

ITEM	PART NO or Config. Code	DESCRIPTION	QTY.
1	8540-1026	Button Head Cap Screw	8
2	8563-1020	End Cover Plate	2
3	8350-1023	Head Screws	8
4	8563-1000	Head	2
5	8563-9026	Drive Pulley Assy	1
	8563-9027	Drive Pulley Assy, Dual	1
6	8563-1025	Retaining Ring	4
7	8563-1032	Spacer	1
8	3420-1644	Socket Head Cap Screw	2
9	8525-1002	Bumper	4
10*	RTBMXB63	Replacement Tube (8563-1010)	A/R
11	8563-9028	Idle Pulley Assy	1
12*	RBMXB63	Belt (8563-1019)	A/R

ITEM	PART NO or Config. Code	DESCRIPTION	QTY.
13	8125-1070	Low Head Cap Screws	12
14	8563-1005	Belt Clamp Bottom	2
15	8563-1004	Belt Clamp, LH	1
16	8563-1027	Nut	4
17	8540-1006	Turnbuckle	1
18	8563-1003	Belt Clamp, RH	1
19	8563-1041	Carrier, Metric	1
	8563-1042	Carrier, Blank	1
	8563-1541	Carrier, Inch (US Standard)	1
20	0604-1038	Socket Head Cap Screw	4

*Specify stroke length when ordering A/R = As Required

PROCEDURE - MXB63U

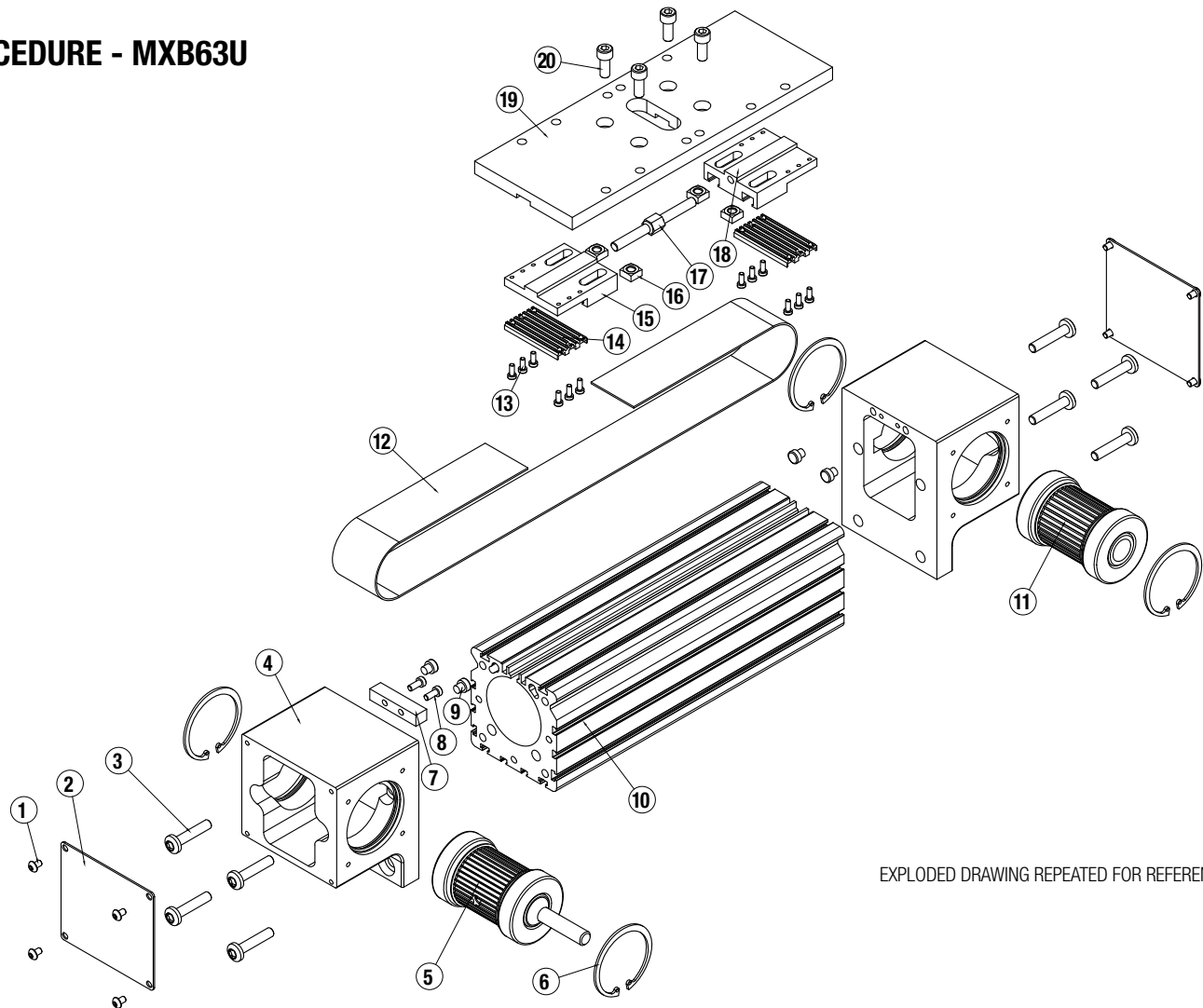

EXPLODED DRAWING REPEATED FOR REFERENCE

GENERAL ACTUATOR DISASSEMBLY

1. Remove End Cover Plates (2). Remove Low Head Cap Screws (20). Remove Carrier Plate (19) exposing the Belt Clamps (15, 18) and the Turnbuckle (17). Loosen the Turnbuckle (17) removing all belt tension.
2. Remove the Belt (12) from the Belt Clamps (15, 18) by removing Fasteners (13) and Belt Clamp Bottom (14). The Belt (12) can now be removed from the actuator.
3. Remove the Retaining Rings (6) from each of the Heads (4). Note that the Bearing/Pulley Assemblies (5, 11) are slip fit into the Head (4), but are bonded in the bore w/ Retaining Compound (Loctite 641 or equivalent), so it may be necessary to press the Pulley Assemblies (5, 11) out of the Head (4).
4. Remove the Heads (4) from the Tube (10) by removing Fasteners (3).

GENERAL ACTUATOR ASSEMBLY

1. Install the Drive and Idle Heads (4) to the Tube (10). Note that the Bumper Spacer (7) installs onto the Drive End Head (4).
2. Install one Retaining Ring (6) into each Head (4). Apply a light coating of Retaining Compound (Loctite 641 or equivalent) to the outside diameter of the bearings of the Pulley Assemblies (5, 11) and to the inside diameter of the bearing bores of the Head (4). Install the Drive and Idle Pulley/Bearing Assemblies (5, 11) into the Heads (4). NOTE THAT ORIENTATION OF THE DRIVE SHAFT IS DETERMINED BY THIS ASSEMBLY STEP. Install the remaining Retaining Ring (6) into each Head (4).
3. Feed the Belt (12) into the Tube (10) from one end of the actuator. Install a Belt Clamp (15, 18) to each end of the Belt (12) with Belt Clamp Bottoms (14) and Fasteners (13). Note that one Belt Clamp (15) will have left hand threads for the Turnbuckle (17). Assemble so that Belt Clamp LH (15) is nearest the drive end Head (4). Start the Turnbuckle (17) into each of the Belt Clamps (15, 18). Position Hex Nuts (16) in their respective slots of the Belt Clamps (15, 18).
4. Position Carrier Plate (19) over the Belt Clamps (15, 18) and install Fasteners (20), leaving loose at this time.
5. TENSION THE BELT: To measure belt tension, position the edge of the Carrier Plate (19) that is nearest the Head (4) 6" from the inside edge of the Head (4) (either end of the actuator). Locate a force gage on the Belt (12) 2" from the inside edge of the Head (4). Support the tube side of the Carrier Plate (19) so that it is rigid to the Tube (10). Deflect the Belt (12) 1/4" [6 mm] in either direction. The force gage should read between 18 and 22 lbs. [80 - 98 N]
6. Adjust the Turnbuckle (17) to achieve this tension, then tighten the Fasteners (20) to secure the Belt Clamps (15, 18) to the Carrier Plate (19).

EXPLODED VIEW & PARTS LIST - LMI - INLINE MOTOR MOUNT

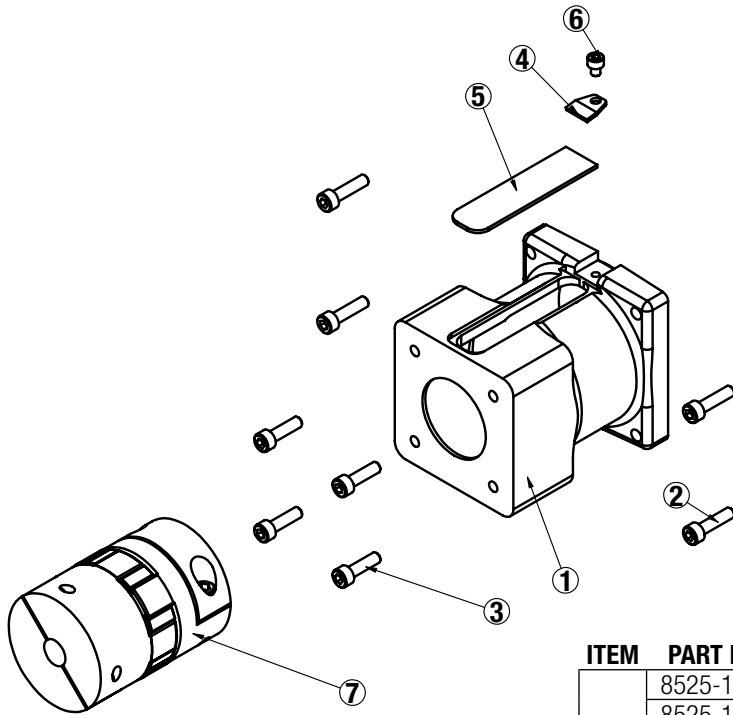

ITEM	PART NO.	DESCRIPTION	MOTOR					MOTOR & GH	
			MRV21,22,23,24	MRV31,32,33	MRS21,22,23	MRS31,32	MRS33	MRV2x, MRS2x & GHV205,210	MRV3x, MRS3x & GHV305,310
1	8525-1051	Motor Spacer	1						
	8525-1053	Motor Spacer		1					
	8525-1050	Motor Spacer			1				
	8525-1052	Motor Spacer				1	1		
	8525-1054	Motor Spacer						1	
	8525-1055	Motor Spacer							1
2	2212-1098	Socket Head Cap Screws	4	4	4	4	4	4	4
3	4415-1063	Socket Head Cap Screws	4	4		4	4		4
	2212-1096	Socket Head Cap Screws			4				
	2212-1097	Socket Head Cap Screws						4	
4	1906-1022	Clamp	1	1	1	1	1	1	1
5	3410-1120	Cover	1	1	1	1	1	1	1
6	1124-1159	Socket Head Cap Screw	1	1	1	1	1	1	1
7	3600-9242	Coupler	1	1		1		1	1
	3410-9157	Coupler			1				
	3600-9244	Coupler					1		

EXPLODED VIEW & PARTS LIST - RP - REVERSE PARALLEL MOTOR MOUNT

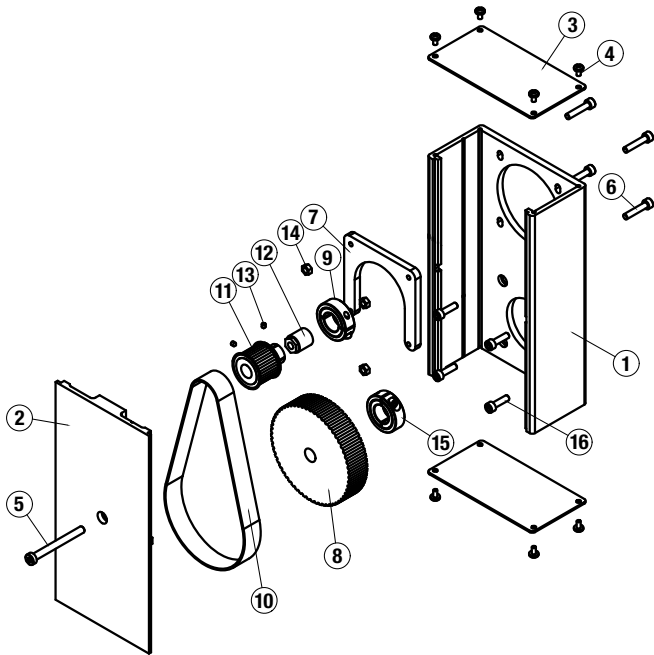

ITEM	PART NO.	DESCRIPTION	MOTOR				
			MRV21, 22, 23, 24	MRV31, 32, 33	MRS21, 22, 23	MRS31, 32	MRS33
1	3420-1603	Housing	1		1		
	3420-1604	Housing		1			
	3420-3034	Housing				1	1
2	3420-1613	Cover	1	1			
	3420-1614	Cover		1			
	3420-3035	Cover				1	1
3	3420-1602	Cap	2	2	2	2	2
	0601-1625	Screw	8	8	8	8	8
4	3420-1641	Low Head Cap Screw	1	1	1	1	1
	2212-1098	Socket Head Cap Screws	4				
6	2212-1099	Socket Head Cap Screws		4		4	4
	2212-1096	Socket Head Cap Screws			4		
	0602-1057	U-plate		1		1	1
8	3415-1439	Pulley	1	1		1	1
	3410-1439	Pulley			1		
9	0520-1067	Collar Clamp				1	
	0515-1080	Collar Clamp					1
10	3415-1441	Belt	1	1			
	3410-1441	Belt			1		
	2164-1008	Belt				1	1
11	3415-1438	Pulley	1	1			
	3420-9191	Pulley			1		
	3415-1436	Pulley				1	
	3420-1436	Pulley					1
12	0510-1111	Trantorque			1		
13	0610-1190	Set Screw	2	2			
14	0603-2089	Nut	4	4			
15	0520-1067	Collar Clamp	1	1	1	1	1
16	3420-1644	Low Head Cap Screws	4	4	4	4	4

PROCEDURE - MXB63U

REVERSE PARALLEL DISASSEMBLY INSTRUCTIONS:

1. Remove End Caps (3). Release tension on Belt (10) by breaking loose the Motor Fasteners (6).
2. Remove RP Cover (2).
3. Remove both Drive Pulley (11) and Driven Pulley (8) from their respective shafts. The Belt (10) will come off with the Pulleys (8, 11).
4. Remove Motor Fasteners (6) from the U-Plate (7), to remove the motor from the Housing (1).
5. Remove the Housing (1) from the Head (page 1 #4) by removing Fasteners (16).

REVERSE PARALLEL ASSEMBLY INSTRUCTIONS:

*Apply Loctite #242 to all fasteners upon installation

1. Install Housing (1) to the Head (page 1 #4) with Cap Screws (16).
2. Install the Motor to the Housing (1) with Fasteners (6) into the U-Plate (7). Do not tighten the Fasteners (6) at this time.
3. Locate the Belt (10) over the Pulleys (8, 11) and slide the Drive (11) and Driven (8) Pulleys over their respective shafts. Tighten each Pulley (8, 11) to its shaft with either Trantorque (12) or Collar Clamp (15). If Trantorque (12), use a torque wrench to apply appropriate torque. 1/2" hex on Trantorque (12) apply 75 in-lbs. (8.5 N-m). 5/8" hex on Trantorque (12) apply 100 in-lbs. (11.3 N-m).

4. Verify that there is clearance between the inside of the Housing (1) and each Pulley (8, 11). Verify that the Pulleys (8, 11) are aligned to each other.
5. Position the Cover (2) in mating slot of the Housing (1) and install the Fastener (5) to hold in place. Take care not to over-tighten. If the Cover (2) is deflected it can interfere with the moving parts.
6. Tension the Belt (10) by pulling the motor away from the Drive Shaft Assembly (page 1 #5) with the appropriate force in the chart below. Tighten the Motor Fasteners (6) while this force is applied to the motor.

Motor Frame	Tension Force
MRB23, MRS17/23	10 lbs (44 N)
MRV23, MRS34	20 lbs (89 N)
MRV34, MRB34	30 lbs (133 N)

7. Install both End Caps (3) with the Screws (4) to finalize assembly.

EXPLODED VIEW & PARTS LIST - OPTIONS

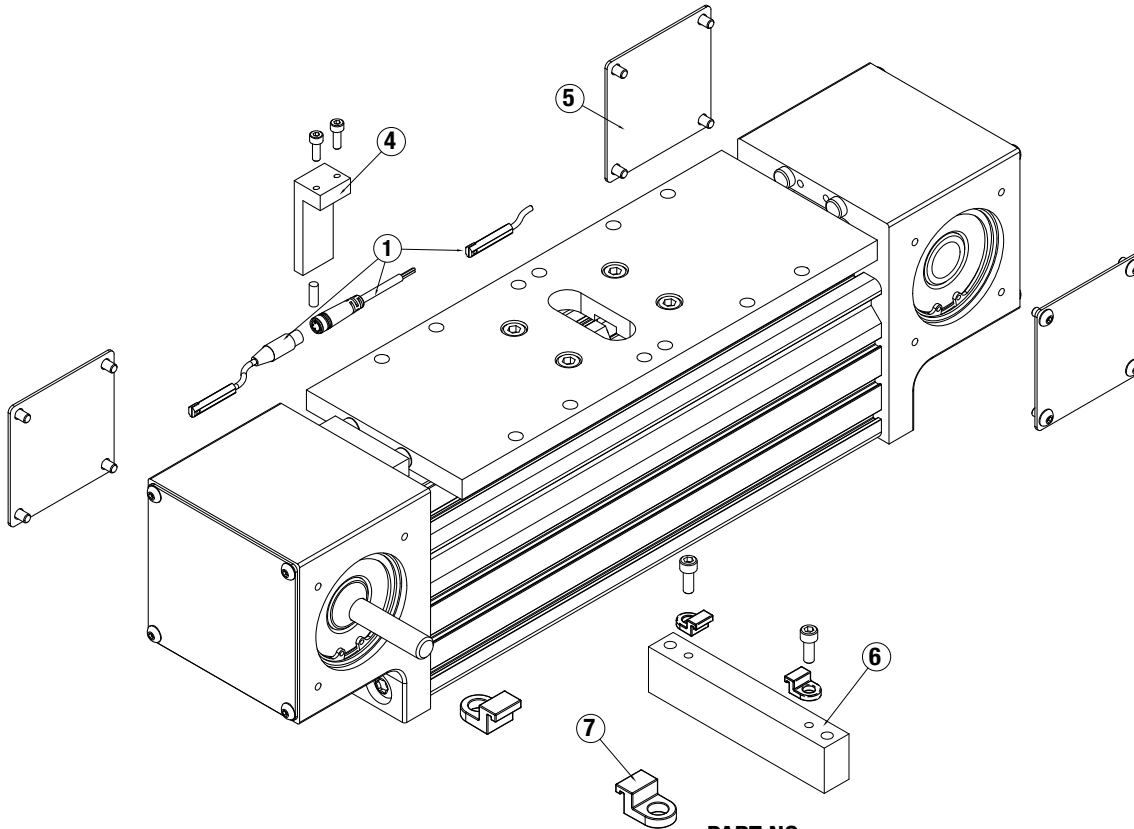

**PART NO. or
ITEM CONFIG. CODE DESCRIPTION**

SWITCHES		
WITH QUICK-DISCONNECT COUPLERS		
1	SWMXB63U	RK Reed Switch, SPST Normally Open
	SWMXB63U	NK Reed Switch, SPST Normally Closed
	SWMXB63U	TK Solid State Switch, PNP (Sourcing) Normally Open
	SWMXB63U	KK Solid State Switch, NPN (Sinking) Normally Open
	SWMXB63U	PK Solid State Switch, PNP (Sourcing) Normally Closed
	SWMXB63U	HK Solid State Switch, NPN (Sinking) Normally Closed
	WITH FLYING LEADS	
1	SWMXB63U	RY Reed Switch, SPST Normally Open
	SWMXB63U	NY Reed Switch, SPST Normally Closed
	SWMXB63U	TY Solid State Switch, PNP (Sourcing) Normally Open
	SWMXB63U	KY Solid State Switch, NPN (Sinking) Normally Open
	SWMXB63U	PY Solid State Switch, PNP (Sourcing) Normally Closed
	SWMXB63U	HY Solid State Switch, NPN (Sinking) Normally Closed
4	8550-9024	Magnet Kit
		8550-1043 Magnet Block
		2212-1093 Low Head Cap Screws
5	8540-9008	8116-1058 Magnet
		Side Cover Plate Assembly
		8540-1020 Cover Plate
6	8363-9016	8540-1026 Button Head Cap Screw
		Mounting Plate Kit
		8363-1031 Mounting Plate
7	8163-9018	8163-1050 Tube Clamp
		Tube Clamp Kit
		8363-1044 Socket Head Cap Screw
		8163-1050 Tube Clamp

SWITCH WIRING DIAGRAMS AND LABEL COLOR CODING (CE and RoHS Compliant)

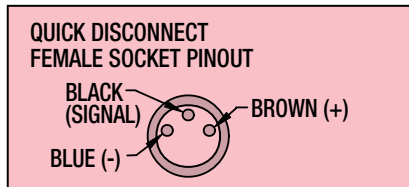
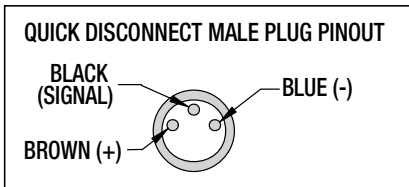
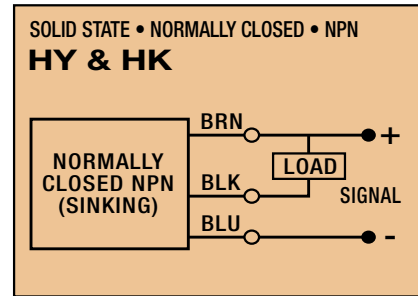
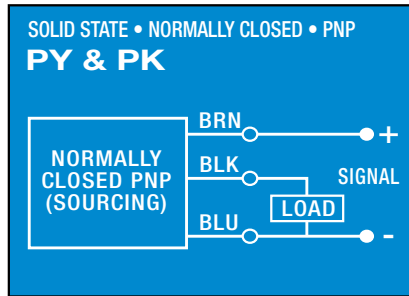
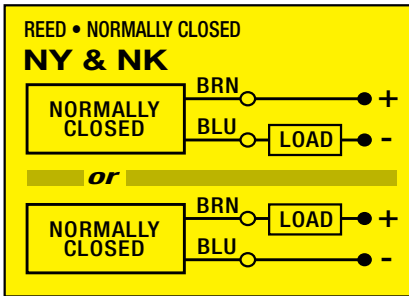
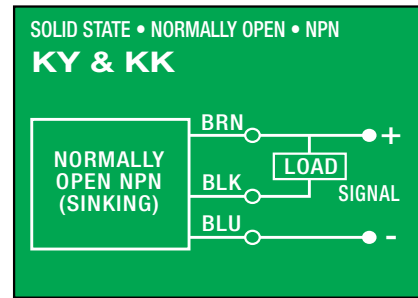
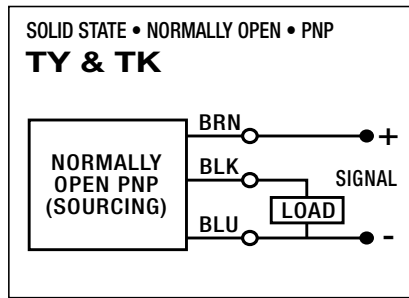
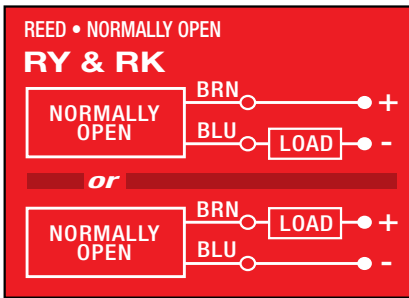

SWITCH INSTALLATION AND REPLACEMENT

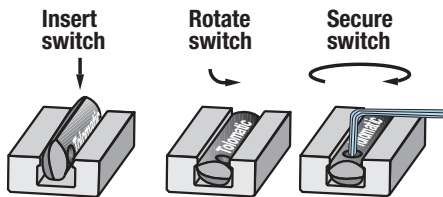

Place switch in side groove on tube at desired location with "Tolomatic" facing outward. While applying light pressure to the switch, rotate the switch halfway into the groove. Maintaining light pressure, rotate the switch in the opposite direction until the switch is fully inside the groove with "Tolomatic" visible. Re-position the switch to the exact location and lock it securely into place by tightening the screw on the switch.

SWITCH DETECTION POINT

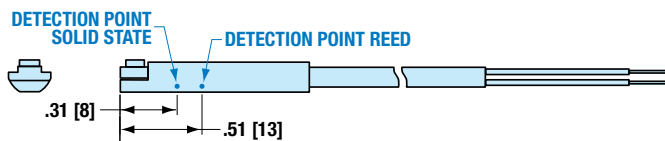

Dimensions in inches [brackets indicate dimensions in millimeters]



3800 County Road 116, Hamel, MN 55340 USA
<http://www.Tolomatic.com> • Email: Help@Tolomatic.com
 Phone: (763) 478-8000 • Fax: (763) 478-8080 • Toll Free: 1-800-328-2174

COMPANY WITH
 QUALITY SYSTEM
 CERTIFIED BY DNV GL
 = ISO 9001 =

All brand and product names are trademarks or registered trademarks of their respective owners. Information in this document is believed accurate at time of printing. However, Tolomatic assumes no responsibility for its use or for any errors that may appear in this document. Tolomatic reserves the right to change the design or operation of the equipment described herein and any associated motion products without notice. Information in this document is subject to change without notice.