

MXE63P Profiled Rail Screw-Drive Actuators

63mm (2-1/2 inch) Series

Models: BN01 BN02
BN04 SN04

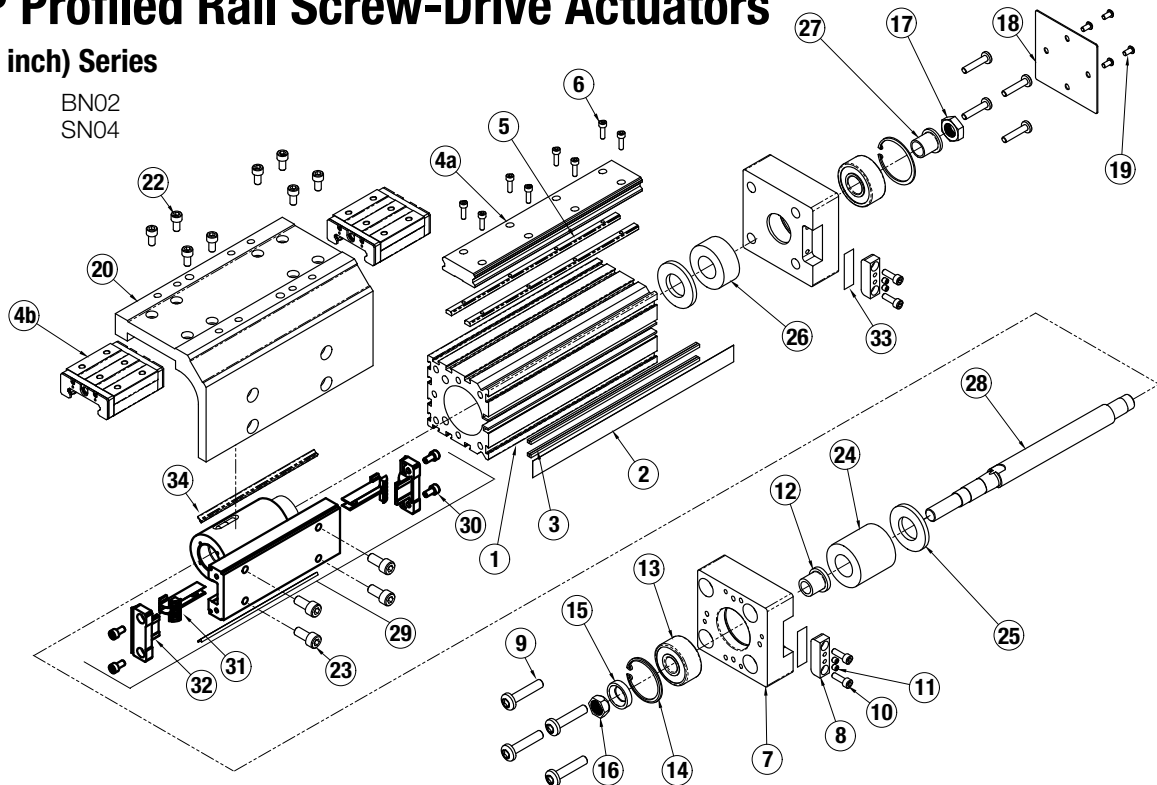

ITEM	PART NO. OR CONFIG. CODE	DESCRIPTION	MXE63P			
			BN01	BN02	BN04	SN04
41.	RTBMXE63_SK_	TUBE (US CONV)	1	1	1	1
	RTBMXE63_SM_	TUBE (METRIC)	1	1	1	1
1,5	NDBMXE63_SK_	DUST BAND (US CONV)	1	1	1	1
	NDBMXE63_SM_	DUST BAND (METRIC)	1	1	1	1
3.	NMBMXE63_SK_	MAGNET BAND KIT (US CONV) (2 MAGNET STRIPS INCLUDED)	1	1	1	1
	NMBMXE63_SM_	MAGNET BAND KIT (2 MAGNET STRIPS INCLUDED)	1	1	1	1
3,64A.	NPRMXE63_SK_	BEARING RAIL (US CONV) ADD BB FOR OPTIONAL BEARING BLOCKS (SEE 4B)	1	1	1	1
	NPRMXE63_SM_	BEARING RAIL (METRIC) ADD BB FOR OPTIONAL BEARING BLOCKS (SEE 4B)	1	1	1	1

ITEM	PART NO. OR CONFIG. CODE	DESCRIPTION	MXE63P			
			BN01	BN02	BN04	SN04
34B.	8163-9060	BEARING BLOCK KIT (SET OF TWO)	1	1	1	1
65.	NNRMXE63_SK_	NUT RAIL KIT (US CONV) (2 RAILS INCLUDED)	1	1	1	1
	NNRMXE63_SM_	NUT RAIL KIT (METRIC) (2 RAILS INCLUDED)	1	1	1	1
6.	4415-1024	SHCS	A/R	A/R	A/R	A/R
7.	8363-1011	HEAD	2	2	2	2
8.	8363-1017	BAND CLAMP	2	2	2	2
9.	8350-1023	PAN HEAD SCREW	8	8	8	8
10.	2212-1031	SOCKET HEAD CAP SCREW	4	4	4	4
11.	8140-1073	SET SCREW	4	4	4	4
12.	1150-1144	TAPERED LEADSCREW SLEEVE	1	1	1	1
13.	2133-1022	BEARING	2	2	2	2

¹ Parts included in Repair Kits. (RKMXE63P_SK_ or RKMXE63P_SM_, indicate stroke length in inches or millimeters)

² Parts included in Nut Bracket Assembly

³ Bearing Blocks and/or Bearing Rail purchased before Oct. 1, 2014 are NOT compatible with current Bearing Blocks and Bearing Rails purchased after Oct. 1, 2014

A/R= Length As Required

⁴ Replacement Tube ordering method: **RTB MXE63P [] [] [] [] SK [] [] [] [] DC []**
EXAMPLE: RTB MXE63P BN02 SK 21.25 DC7

⁵ Replacement ordering method: **[] [] MXE63P SK [] [] [] [] DC []**
EXAMPLE: NDB MXE63P SK 21.25 DC7

Magnet Band (NMB) or Dust Band (NDB) Model & Size Bearing Stroke Length Aux. Carrier

⁶ Replacement ordering method: **[] [] MXE63 [] [] [] [] SK [] [] [] [] DC []**
EXAMPLE: NPR MXE63 BN02 SK 21.25 DC7

Bearing Rail (NPR) or Nut Rail (NNR) Model & Size Nut Style & Size Stroke Length Aux. Carrier

Auxiliary Carrier Option Note: If replacing a Tube (1.), Dust Band (2.), Magnet Band Kit (3.), Bearing Rail (4.), Nut Rail Kit (5.), or Lead Screw (28.) on an actuator that has an Auxiliary Carrier, be sure to add "DC ___" to the end of the configuration string when ordering. "DC" indicates the need for additional length and "___" indicates the measurement of space between carriers (in inches [SK] or millimeters [SM] as indicated earlier in the configuration string).

Drawing repeated for reference

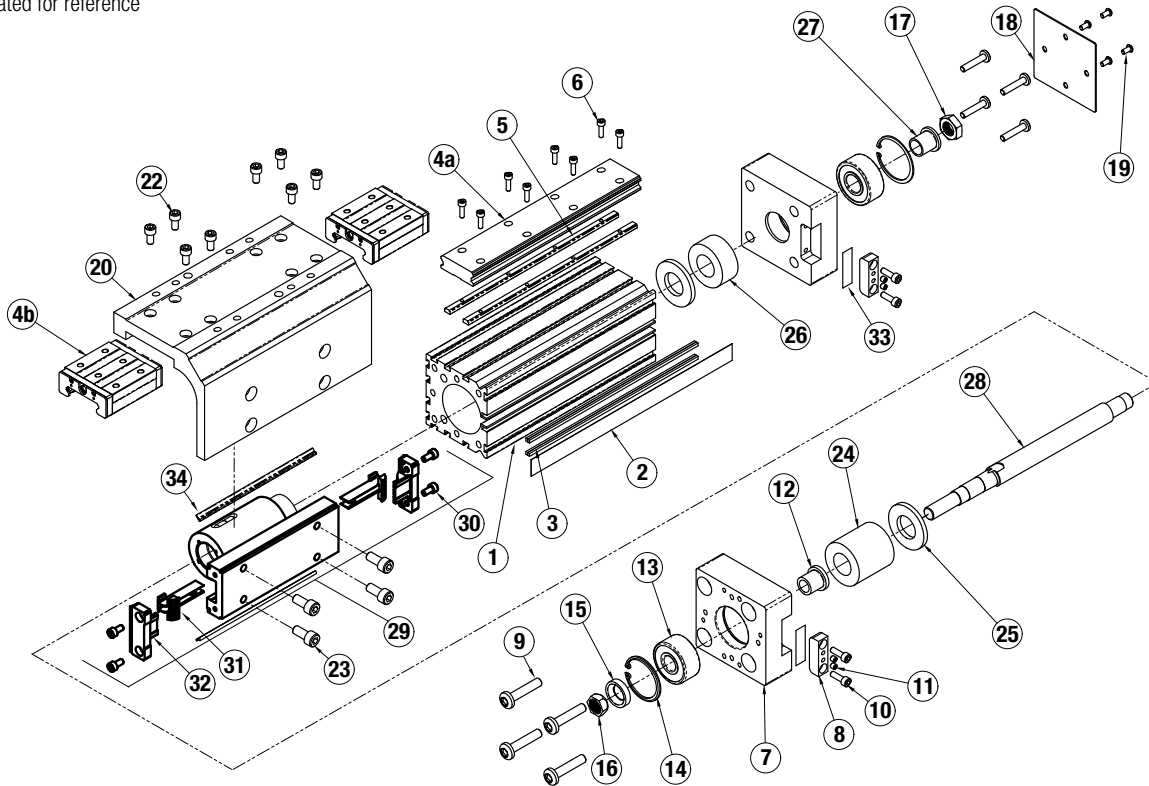

ITEM	PART NO. OR CONFIG. CODE	DESCRIPTION	MXE63P			
			BN01	BN02	BN04	SN04
14.	2133-1021	RETAINING RING	2	2	2	2
15.	1150-1114	SPHERICAL WASHER	1	1	1	1
16.	1150-1113	SPIRALOCK SPHERICAL NUT	1	1	1	1
17.	2124-1023	HEX NUT	1	1	1	1
18.	8363-1022	COVER PLATE	1	1	1	1
19.	8340-1009	BUTTON HEAD CAP SCREW	4	4	4	4
20.	8363-1521	CARRIER (US CONV)	1	1	1	1
	8363-1021	CARRIER (METRIC)	1	1	1	1
22.	4415-1000	SOCKET HEAD CAP SCREW	8	8	8	8
23.	2164-1065	SOCKET HEAD CAP SCREW, SS	4	4	4	4
24.	8363-1024	NYLON SPACER	1	1	1	1
25.	8363-1023	BUMPER	1	1	1	1
26.	8363-1025	NYLON SPACER	1	1	1	1
27.	8363-1027	FLANGED SLEEVE BEARING	1	1	1	1
528.	RLSAMXE63_SK_	LEADSCREW (US CONV)	A/R	A/R	A/R	A/R
	RLSAMXE63_SM_	LEADSCREW (METRIC)	A/R	A/R	A/R	A/R

ITEM	PART NO. OR CONFIG. CODE	DESCRIPTION	MXE63P			
			BN01	BN02	BN04	SN04
29.	8363-9006	NUT BRACKET ASSEMBLY, BN01	1	-	-	-
	8363-9007	NUT BRACKET ASSEMBLY, BN02	-	1	-	-
	8363-9008	NUT BRACKET ASSEMBLY, BN04	-	-	1	-
	8363-9009	NUT BRACKET ASSEMBLY, SN04	-	-	-	1
30.	0603-1016	SOCKET HEAD CAP SCREW, SS	4	4	4	4
1,231.	8363-1007	BAND RAMP	2	2	2	2
1,232.	8163-1006	END CAP	2	2	2	2
33.	8363-1028	SHIM	2	2	2	2
	8363-1029	SHIM	2	2	2	2
134.	8163-1059	WIPER	2	2	2	2

¹ Parts included in Repair Kits. (RKMXE63P_SK_ or RKMXE63P_SM_, indicate stroke length in inches or millimeters)

² Parts included in Nut Bracket Assembly

³ Bearing Blocks and/or Bearing Rail purchased before Oct. 1, 2014 are NOT compatible with current Bearing Blocks and Bearing Rails purchased after Oct. 1, 2014
A/R= Length As Required

⁶ Replacement Lead Screw ordering method: **RLS** **MXE63P** **□□□□** **SK** **□□□□** **LM** **I** **Y** **M** **□□□□** **DC** **□**

EXAMPLE: **RLS** **MXE63P** **B** **N02** **S** **K** **211-25** **L** **M** **I** **Y** **M** **0** **T** **B** **D** **0** **DC** **7**

Lead Screw Bearing Nut Style & Size Stroke Length Motor Orientation Motor Code Aux. Carrier

Auxiliary Carrier Option Note: If replacing a Tube (1.), Dust Band (2.), Magnet Band Kit (3.), Bearing Rail (4.), Nut Rail Kit (5.), or Lead Screw (28.) on an actuator that has an Auxiliary Carrier, be sure to add "DC ___" to the end of the configuration string when ordering. "DC" indicates the need for additional length and "___" indicates the measurement of space between carriers (in inches [SK] or millimeters [SM] as indicated earlier in the configuration string).

Assembly and Disassembly Instructions

GENERAL ACTUATOR DISASSEMBLY INSTRUCTIONS

Begin with a clean work area. Be sure all replacement parts are present and have no visual damage or defects. The following tools are recommended for proper disassembly and assembly.

- SAE Hex Wrench Set
- Metric Hex Wrench Set
- Torx bit set
- Metric Socket Set
- SAE Socket Set

For best actuator performance it is recommended that the following instructions be read and followed carefully.

1. DUST BAND AND CARRIER REMOVAL

Position the actuator with the Dust Band (2) facing up. Remove the Band Clamps (8) from both Heads (7) of the actuator by removing Screws (9) and backing out the Center Set Screw (11) a couple turns. Carefully lift the Dust Band (2) from the slot in each Head (7) and remove any Shims (33) located under the Band (2) in the Head (7) slot. Retain the Shims (33) for reassembly. Remove Screws (23) to release the Carrier (20) from the Nut Bracket Assembly (29). Slide the Carrier (20) clear of the Nut Bracket (29). Remove Nut Bracket End Caps (32) from both ends of the Nut Bracket (29). The Dust Band (2) can now be removed from the actuator.

NOTE: If removal of the Bearing Rail (4a) or Bearing Blocks (4b) is necessary, contact the factory prior to removal for specific instructions.

2. LEAD SCREW SUB-ASSEMBLY REMOVAL

On the Non-Drive End of the actuator remove the Screws (19) and remove the Cover Plate (18) and the Lock Nut (17) from Leadscrew (28). Remove the Screws (9) from both of the Heads (7) to the Tube (1). Remove the Non-Drive End Head (7) and the Drive Head (7)/Leadscrew Assembly (28). If necessary, the Nut Bracket Assembly (29) can now be removed from the Leadscrew (28) and the Band Ramps (31) may also be removed from the Nut Bracket Assembly (29) if required.

Ball Nut style: Caution is required if removal of the Nut is necessary. Contact the factory for available parts and procedures.

Plastic Nut style: Plastic Nuts are factory pinned into the Nut Bracket (29) and cannot be removed. If Nuts are worn, a new Nut Bracket Assembly (29) must be ordered.

If Drive End Head (7) and Bearing (13) must be removed from the Leadscrew (28), contact the factory prior to removal for specific instructions.

GENERAL CYLINDER ASSEMBLY INSTRUCTIONS

1. INSTALL LEAD SCREW ASSEMBLY AND CARRIER

Install the Band Ramps (31) to the Nut Bracket Assembly (29) with Screws (30). From the Drive End, install the Head (7)/Leadscrew (28)/Nut Bracket Assembly (29) into the Tube (1) making sure the Bearing Rail (4a) is oriented on the left side of the Tube (1). With the Bumper (25) and Nut Spacer (24) in place, position the Non-Drive End Head (7) over the Leadscrew (28) and loosely install Screws (9) into the Head (7). Install the Drive End Screws (9) loosely into the Drive End Head (7).

2. INSTALL DUST BAND AND CARRIER

Install the Dust Band (2) through the Nut Bracket Assembly (29) and install the End Caps (32) onto the Nut Bracket (29). Position Carrier (20) over the Bearing Blocks (4b) and the Nut Bracket (29) and install all Screws (22,23) and leave them loose at this time. By hand, load the Carrier (20) to keep it tight down on the surface of the Bearing Blocks (4b) and tighten the Carrier (20) to Nut Bracket Fasteners (23). Tighten the Carrier (20) to Bearing Block Fasteners (22).

3. PERFORM HEAD ALIGNMENT AND FINAL ASSEMBLY

NOTE: Custom tooling is used at the factory to align the Heads (7) to the Tube (1) to maintain parallelism between the top of the Head (7) and top of the Tube (1). This is critical to performance and longevity of the Dust Band (2). In the following steps take care to visually align Head (7) to Tube (1).

Move Carrier Assembly (20) to Drive-End of Tube (1) and tighten one of the Head Screws (9). Support the actuator on the Tube (1) so that the Head (7) is free to float while tightening the Head Screws (9).

Move Carrier Assembly (20) to idle end of Tube (1) and tighten these Head Screws (9).

Move Carrier Assembly (20) back to the Drive-End of Tube (1) and loosen the Screw (9) that was previously tightened and then tighten all Head Screws (9).

Apply Loctite 242 to Lock Nut (17) and thread onto the Leadscrew (28) and torque to 18-20 in-lbs (2-2.25 N-m).

4. INSTALL BAND CLAMPS

Visually examine the interface between the Dust Band (2) surface of the Tube (1) and the clamping surface of each Head (7). This should be flush. It may be necessary to install Shims (33) in the pocket of the Head (7) in order to make flush. Position the Carrier (20) near the motor end, position the Band (2) in the pocket over any previously installed Shims (33) and install the Band Clamp (8) with the two Cap Screws (10). Lastly, tighten down the Center Set Screw (11). Position the Carrier (20) near the Non-Drive End and repeat the steps to install the Band Clamp (8).

In-Line (LMI) Mounting Options

ITEM	PART NO.	DESCRIPTION	QTY
◊44.	CONFIGURED	MOTOR SPACER	1
◊45.	CONFIGURED	DOWEL PIN	2
◊46.	CONFIGURED	SCREW	4
◊47.	CONFIGURED	SCREW	4
◊48.	CONFIGURED	COVER	1
◊49.	CONFIGURED	CLAMP	1
◊50.	CONFIGURED	SCREW	1
◊51.	CONFIGURED	COUPLER	1

◊ Part number varies depending on YMH (Your Motor Here).
Contact help@tolomatic.com for replacement part number.

A replacement Motor Mount Kit contains all parts listed above.

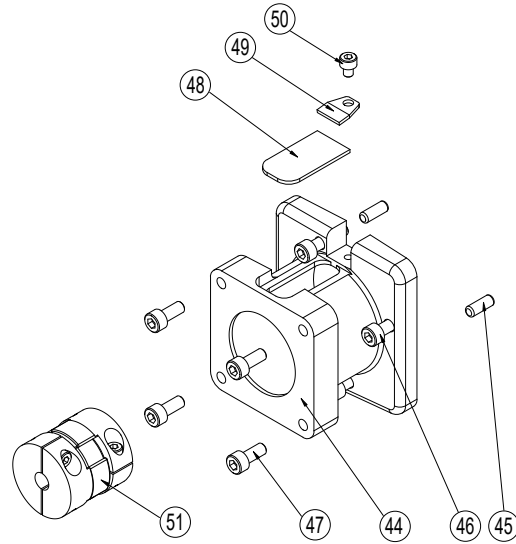

Replacement Motor Mount Kits ordering method: **MMK MXE63P** **LMI YM**

EXAMPLE: MMK MXE63P SN02 LMI YM011001

Motor Mount Kit ———— | Bearing Style | Lead Screw | Motor Orientation

Model & Size ———— | ———— | ———— | ————

Reverse Parallel (RP) Mounting Option

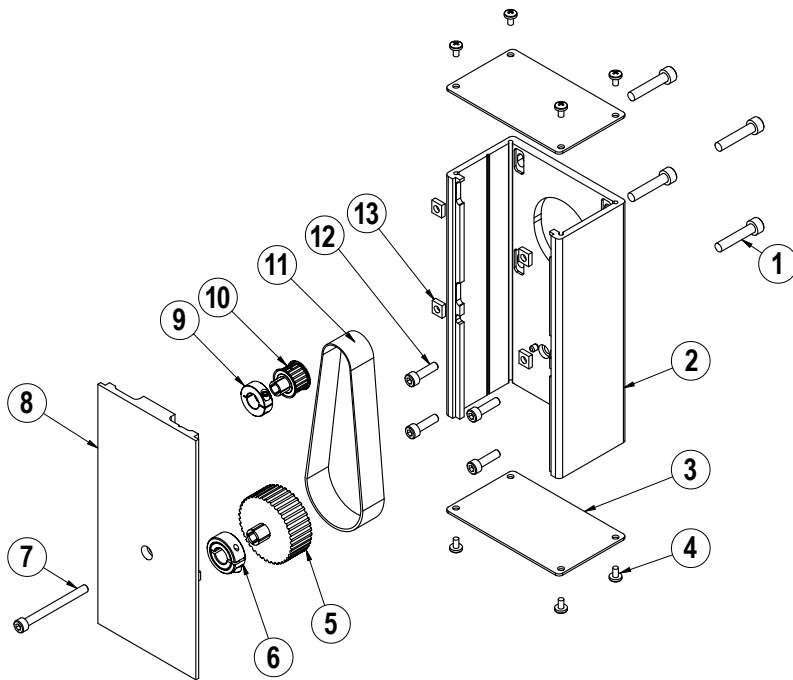

ITEM	PART NO.	DESCRIPTION	QTY.
◊1.	CONFIGURED	MOTOR FASTENER	4
◊2.	CONFIGURED	RP HOUSING	1
◊3.	CONFIGURED	RP HOUSING END CAP	2
◊4.	CONFIGURED	END CAP SCREW	8
◊5.	CONFIGURED	DRIVE SHAFT PULLEY	1
◊6.	CONFIGURED	COLLAR CLAMP, DRIVE SHAFT	1
◊7.	CONFIGURED	RP COVER FASTENER	1
◊8.	CONFIGURED	RP COVER	1
◊9.	CONFIGURED	COLLAR CLAMP, MOTOR	1
◊10.	CONFIGURED	MOTOR PULLEY	1
◊11.	CONFIGURED	BELT	1
◊12.	CONFIGURED	RP PLATE FASTENER	4
◊13.	CONFIGURED	SQUARE NUT	4

◊ Part numbers varies depending on YMH (Your Motor Here).
Contact help@tolomatic.com for replacement part numbers.

Disassembly Instructions

1. Remove End Caps (3), and release the tension on the Belt (11) by breaking loose the motor fasteners (1).
2. Remove the RP Cover (8).
3. The Belt (11) can now be removed along with the Motor.
4. Remove both Pulleys (10) and (5) from their respective shafts.
5. Remove the RP Housing (2) from the actuator head by removing the Fasteners (12).

Assembly Instructions

Note: Apply Loctite #242 to all fasteners upon installation

1. Install RP Housing (2) onto the actuator Head with Fasteners (12).
2. Install the Motor to the RP Housing with Fasteners (1) and Square Nuts (13). Do not tighten the fasteners at this time.
3. Locate the Belt (11) over the Pulleys (10) and (5) and slide both pulleys over their respective shafts. Tighten each pulley to its shaft with the Collar Clamps (9) and (6).
4. Position the Cover (8) in the mating slot of the RP case and install the Fasteners (7) to hold it in place. Take care not to overtighten. If the cover is deflected, it can interfere with the leadscrew.
5. Tension the Belt (11) by pulling the motor away from the drive shaft with the appropriate tension force shown in the chart below. While tensioning, the actuator should be positioned so the weight of the motor does not affect the belt tension. Tighten the Motor Fasteners (1) while the tensioning force is applied to the motor.

SMALLEST SHAFT DIAMETER (Motor or Actuator)		TOTAL WEIGHT TO APPLY	
Inches	mm	lbs	kgs
0.18 to 0.259	4.572 to 6.579	13	5.902
0.260 to 0.499	6.604 to 12.675	22	9.988
0.500 to 0.625	12.7 to 15.875	31	14.074
0.625 and larger	15.875 and larger	40	18.160

Additional tips are found in Tolomatic [Electric Actuator Motor Mounts Technical Note # 3600-4203](#).

6. Verify that there is clearance between the inside of the RP case and each pulley. Verify the pulleys are aligned to each other.
7. Install both End Caps (3) with the Screws (4) to finalize the assembly.

Actuator Options

ITEM	PART NO.	DESCRIPTION	QTY IN KIT
1	8363-9514	AUXILIARY CARRIER ASSEMBLY, (US CONV)	
	8363-9014	AUXILIARY CARRIER ASSEMBLY, (METRIC)	
2	8163-9018	TUBE CLIP MOUNT KIT	
	8163-1050	TUBE CLAMP	2
3	8363-9016	MOUNTING PLATE KIT	
	8363-1031	MOUNTING PLATE	1
	8163-1050	TUBE CLAMP	2
	8363-1044	SOCKET HEAD CAP SCREW	2

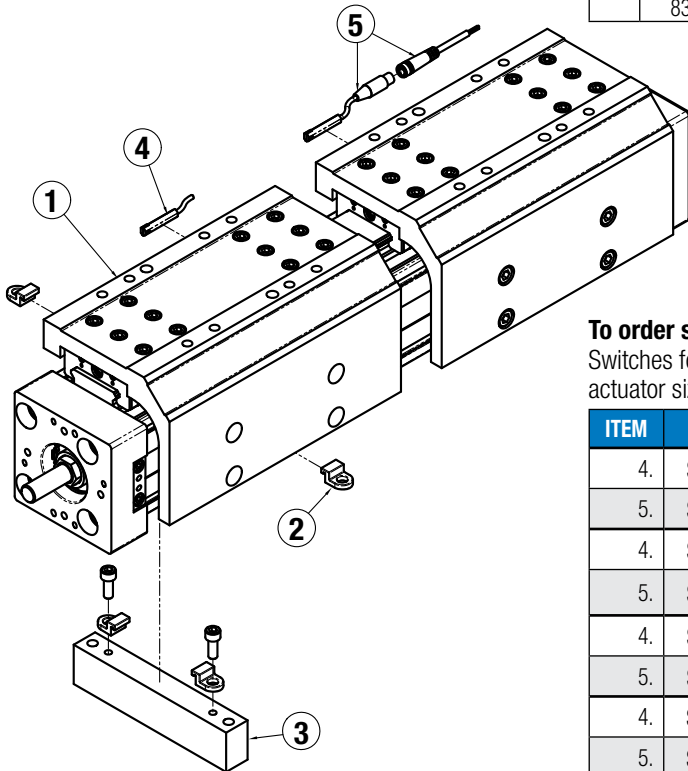

To order service parts switches:

Switches for MXE include retained mounting hardware and are the same for all actuator sizes and bearing styles

ITEM	CONFIG. CODE	LEAD	NORMALLY	SENSOR TYPE
4.	SWMXE63P RY	5M (197 IN)	OPEN	REED
5.	SWMXE63P RK	QUICK-DISCONNECT		
4.	SWMXE63P NY	5M (197 IN)	CLOSED	REED
5.	SWMXE63P NK	QUICK-DISCONNECT		
4.	SWMXE63P TY	5M (197 IN)	OPEN	SOLID STATE PNP
5.	SWMXE63P TK	QUICK-DISCONNECT		
4.	SWMXE63P KY	5M (197 IN)	OPEN	SOLID STATE NPN
5.	SWMXE63P KK	QUICK-DISCONNECT		
4.	SWMXE63P PY	5M (197 IN)	CLOSED	SOLID STATE PNP
5.	SWMXE63P PK	QUICK-DISCONNECT		
4.	SWMXE63P HY	5M (197 IN)	CLOSED	SOLID STATE NPN
5.	SWMXE63P HK	QUICK-DISCONNECT		

NOTE: When ordering Quick-disconnect mating female connector is included

Ordering Repair Kits

Repair kit includes: dust band, end caps, wipers, solid bearings, bearing end caps

The part number for a repair kit begins with RK followed by model, actuator size, bearing type, and stroke length (**SK** = inch/US Standard, **SM**= metric)

(NOTE: If unit has an auxiliary carrier also include DC and distance between carrier centers)

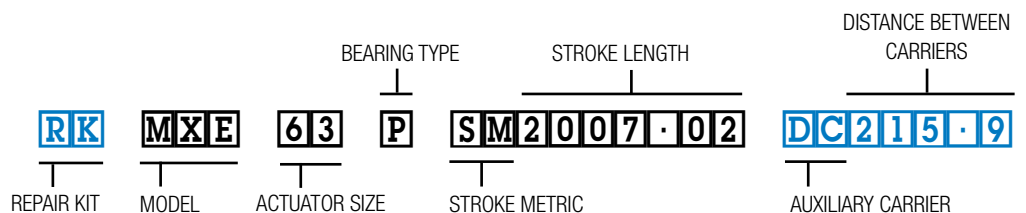

Switch Wiring Diagrams and Label Color Coding (Ce and Rohs Compliant)

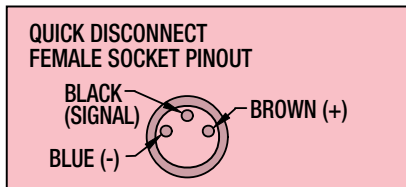
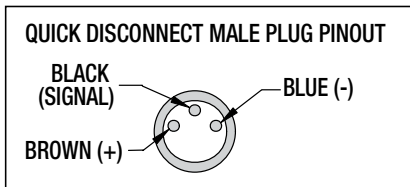
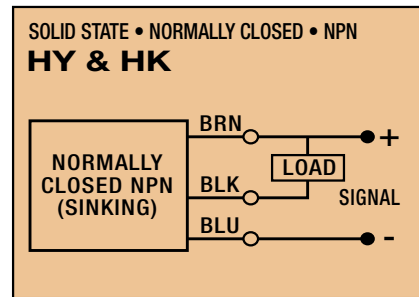
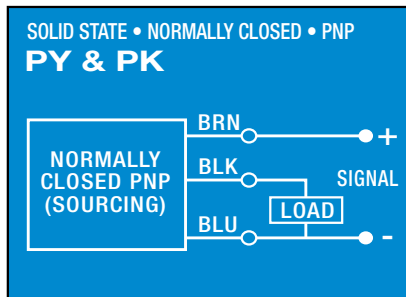
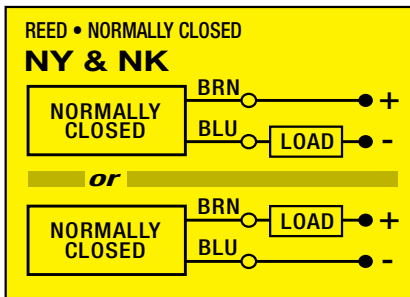
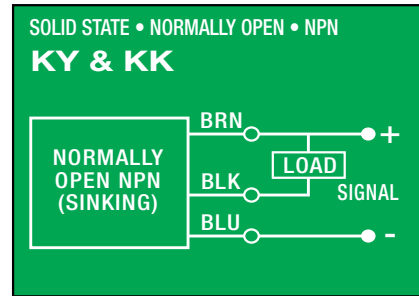
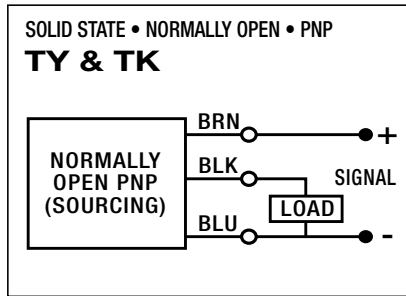
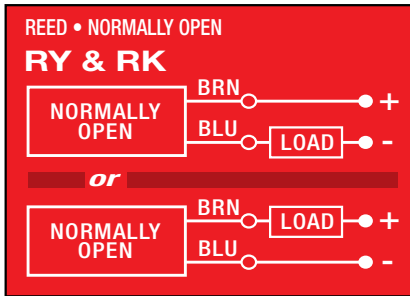

Switches for MX:

- Include retained mounting hardware
- In slot, sit below extrusion profile
- Same for all sizes and bearing styles

Switch installation and replacement

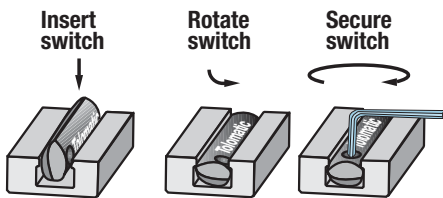

Place switch in side groove on tube at desired location with "Tolomatic" facing outward. While applying light pressure to the switch, rotate it such that the switch is halfway in the groove. Maintaining light pressure, rotate the switch in the opposite direction until the switch is fully inside the groove with "Tolomatic" visible. Re-position the switch to the exact location and lock the switch securely into place by tightening the screw on the switch.

Switch Detection point

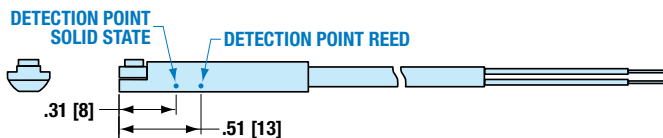

Dimensions in inches [brackets indicate dimensions in millimeters]



3800 County Road 116, Hamel, MN 55340 USA
<http://www.Tolomatic.com> • Email: Help@Tolomatic.com
 Phone: (763) 478-8000 • Fax: (763) 478-8080 • Toll Free: 1-800-328-2174

COMPANY WITH
 QUALITY SYSTEM
 CERTIFIED BY DNV
 = ISO 9001 =

All brand and product names are trademarks or registered trademarks of their respective owners. Information in this document is believed accurate at time of printing. However, Tolomatic assumes no responsibility for its use or for any errors that may appear in this document. Tolomatic reserves the right to change the design or operation of the equipment described herein and any associated motion products without notice. Information in this document is subject to change without notice.