

MXE25P Profiled Rail Bearing Screw-Drive Actuators

25mm (1 inch) Series

Models: BN08 BNL08 BNM10
SN01 SN02 SN05

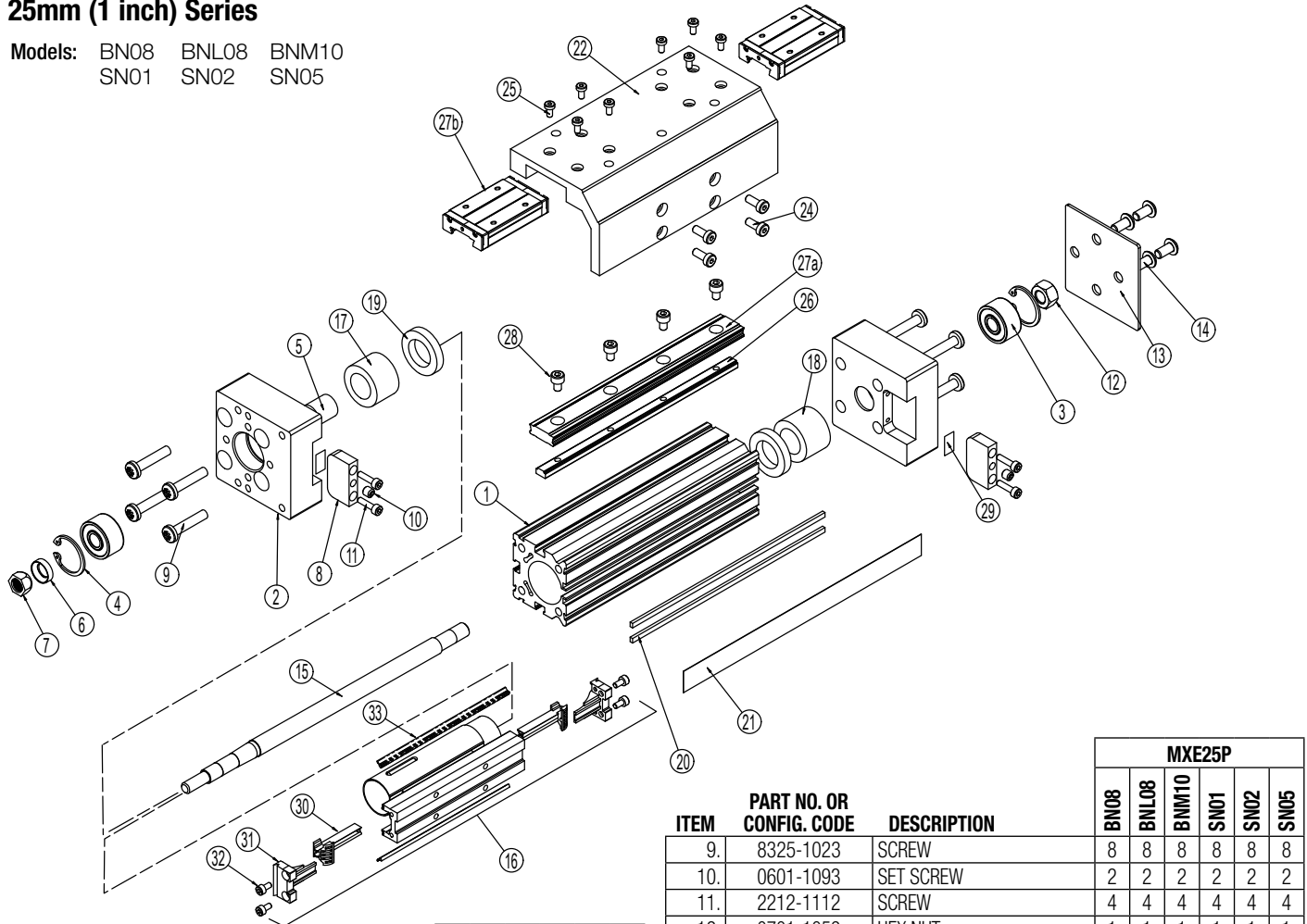

ITEM	PART NO. OR CONFIG. CODE	DESCRIPTION	MXE25P					
			BN08	BNL08	BNM10	SN01	SN02	SN05
1.	RTBMXE25_SK_	TUBE (US CONV)	A/R	A/R	A/R	A/R	A/R	A/R
	RTBMXE25_SM_	TUBE (US CONV)	A/R	A/R	A/R	A/R	A/R	A/R
2.	8325-1011	HEAD	2	2	2	2	2	2
3.	4510-1060	BEARING	2	2	2	2	2	2
4.	3410-1207	RETAINING RING	2	2	2	2	2	2
5.	3410-2041	SLEEVE	1	1	1	1	1	1
6.	3410-2014	WASHER	1	1	1	1	1	1
7.	3410-2013	LOCK NUT	1	1	1	1	1	1
8.	8325-1017	BAND CLAMP	2	2	2	2	2	2

ITEM	PART NO. OR CONFIG. CODE	DESCRIPTION	MXE25P					
			BN08	BNL08	BNM10	SN01	SN02	SN05
9.	8325-1023	SCREW	8	8	8	8	8	8
10.	0601-1093	SET SCREW	2	2	2	2	2	2
11.	2212-1112	SCREW	4	4	4	4	4	4
12.	0701-1059	HEX NUT	1	1	1	1	1	1
13.	8325-1022	COVER PLATE	1	1	1	1	1	1
14.	0110-1424	SCREW	4	4	4	4	4	4
15.	RLSMXE25_SK_	LEADSCREW (US CONV)	A/R	A/R	A/R	-	-	-
	RLSMXE25_SM_	LEADSCREW (METRIC)	A/R	A/R	A/R	-	-	-
16.	8325-9006	NUT BRACKET ASSY, SN01	-	-	-	1	-	-
	8325-9007	NUT BRACKET ASSY, SN02	-	-	-	-	1	-
	8325-9008	NUT BRACKET ASSY, SN05	-	-	-	-	-	1
	8325-9069	NUT BRACKET ASSY, BNM10	-	-	1	-	-	-
17.	8325-1024	SOLID NUT SPACER	-	-	-	1	1	1
	8325-1026	BALL NUT SPACER	1	1	1	-	-	-
18.	8325-1025	SPACER	1	1	1	1	1	1

³ Replacement solid nut bracket assembly kit available. Contact help@tolomatic.com.

⁴ Parts included in Nut Bracket Assembly.

A/ R= As Required

¹ Replacement Tube ordering method: **RTB MXE25P [] [] [] [] SK [] [] [] [] DC []**

EXAMPLE: RTB MXE25P BN02 SK211.25 DC7

² Replacement Lead Screw ordering method: **RLS MXE25P [] [] [] [] SK [] [] [] [] LMIYM [] [] [] [] DC []**

EXAMPLE: RLS MXE25P BN02 SK211.25 LMIYM0TBD0 DC7

Lead Screw Bearing Nut Style & Size Stroke Length Motor Orientation Motor Code Aux. Carrier

Auxiliary Carrier Option Note: If replacing a Lead Screw (15.), Tube (1.) or Dust Band (15.) on an actuator that has an Auxiliary Carrier, be sure to add "DC _ _ _" to the end of the configuration string when ordering. "DC" indicates the need for additional length and "_ _ _" indicates the measurement of space between carriers (in inches [SK] or millimeters [SM] as indicated earlier in the configuration string).

Drawing repeated for reference

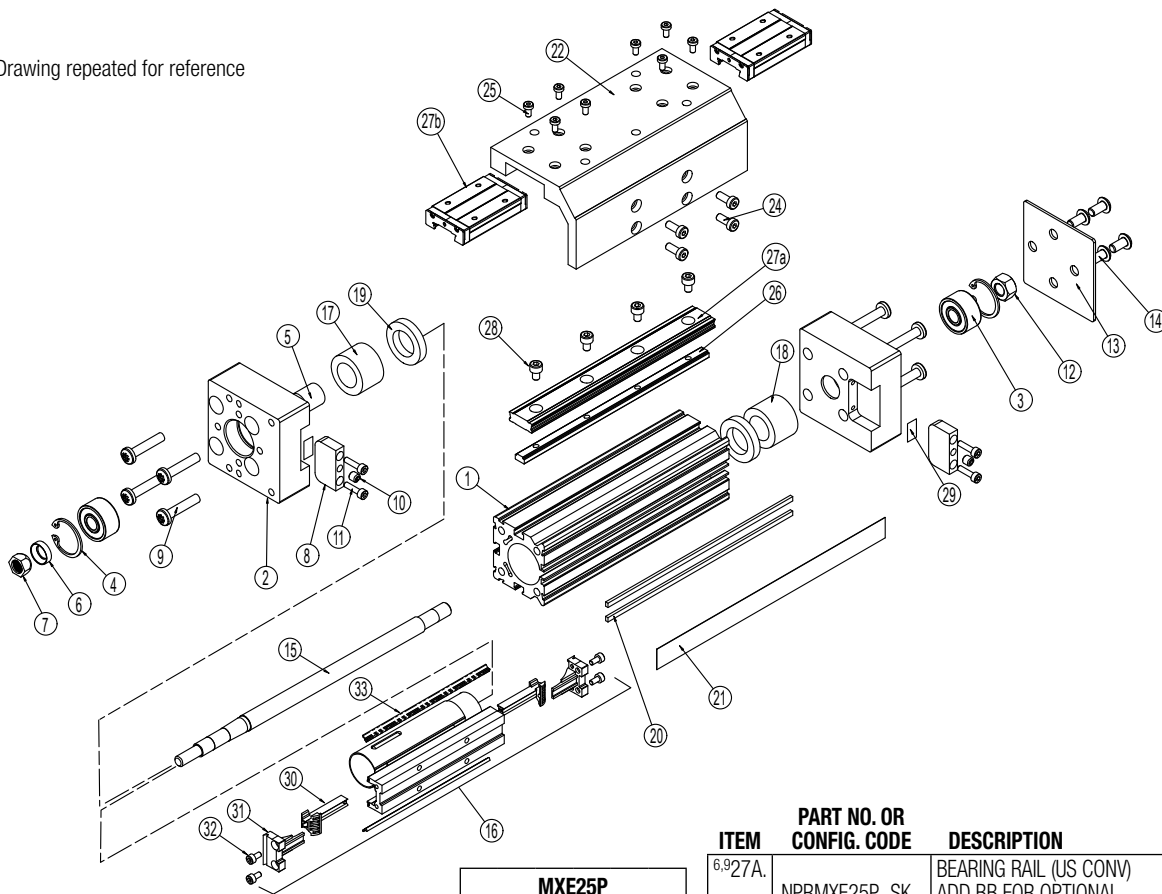

ITEM	PART NO. OR CONFIG. CODE	DESCRIPTION	MXE25P					
			BN08	BNL08	BNM10	SN01	SN02	SN05
19.	3410-1218	BUMPER	2	2	2	2	2	2
20.	NMBMXE25_SK_	MAGNET BAND KIT (US CONV)	2	2	2	2	2	2
	NMBMXE25_SM_	MAGNET BAND KIT (METRIC)	2	2	2	2	2	2
21.	NDBMXE25_SK_	DUST BAND (US CONV)	1	1	1	1	1	1
	NDBMXE25_SM_	DUST BAND (METRIC)	1	1	1	1	1	1
22.	8325-1021	CARRIER, (METRIC)	1	1	1	1	1	1
	8325-1521	CARRIER, (US CONV)	1	1	1	1	1	1
24.	8325-1027	SCREW	4	4	4	4	4	4
25.	8125-1022	SCREW	8	8	8	8	8	8
26.	NNRMXE25_SK_	NUT RAIL KIT (US CONV)	1	1	1	1	1	1
	NNRMXE25_SM_	NUT RAIL KIT (METRIC)	1	1	1	1	1	1

ITEM	PART NO. OR CONFIG. CODE	DESCRIPTION	MXE25P					
			BN08	BNL08	BNM10	SN01	SN02	SN05
6.927A.	NPRMXE25P_SK_	BEARING RAIL (US CONV) ADD BB FOR OPTIONAL BEARING BLOCKS (SEE 27B)	1	1	1	1	1	1
	NPRMXE25P_SM_	BEARING RAIL (METRIC) ADD BB FOR OPTIONAL BEARING BLOCKS (SEE 27B)	1	1	1	1	1	1
6.927B.	8125-9160	BEARING BLOCK KIT (SET OF 2)	1	1	1	1	1	1
28.	8125-1023	SCREW	A/R	A/R	A/R	A/R	A/R	A/R
29.	8325-1055	SHIM, .005 THICK	2	2	2	2	2	2
	8325-1056	SHIM, .010 THICK	2	2	2	2	2	2
	8325-1057	SHIM, .020 THICK	2	2	2	2	2	2
3.530.	8325-1007	BAND RAMP	2	2	2	2	2	2
3.531.	8125-1006	END CAP	2	2	2	2	2	2
32.	0601-1038	SCREW	4	4	4	4	4	4
533.	8125-1059	WIPER	2	2	2	2	2	2

³ Replacement solid nut bracket assembly kit available. Contact help@tolomatic.com.

⁴ Parts included in Nut Bracket Assembly.

⁵ Parts included in Repair Kits. (RKMXE40P_SK_ or RKMXE40P_SM_, indicate stroke length in inches or millimeters)

⁶ Bearing Blocks and/or Bearing Rail purchased before Oct. 1, 2014 are NOT compatible with current Bearing Blocks and Bearing Rails purchased after Oct. 1, 2014.

A/R= As Required

⁶ Replacement Magnet Band ordering method: **NMB MXE25P SK [] [] [] [] DC [] []**

EXAMPLE: NMB MXE25P SK 211-25 DC 7

⁷ Replacement Dust Band ordering method: **NDB MXE25P SK [] [] [] [] DC [] []**

EXAMPLE: NDB MXE25P SK 211-25 DC 7

Dust band Model & Size Bearing Stroke Length Aux. Carrier

⁸ Replacement Nut Rail ordering method: **NNR MXE25 [] [] [] SK [] [] [] [] DC [] []**

EXAMPLE: NNR MXE25 BNL02 SK 211-25 DC 7

⁹ Replacement Bearing Rail ordering method: **NPR MXE25 [] [] [] SK [] [] [] [] DC [] []**

EXAMPLE: NPR MXE25 BNL02 SK 211-25 DC 7

Bearing Rail Model & Size Nut Style & Size Stroke Length Aux. Carrier

Auxiliary Carrier Option Note: If replacing a Lead Screw (15.), Tube (1.) or Dust Band (15.) on an actuator that has an Auxiliary Carrier, be sure to add "DC ___" to the end of the configuration string when ordering. "DC" indicates the need for additional length and "___" indicates the measurement of space between carriers (in inches [SK] or millimeters [SM] as indicated earlier in the configuration string).

Assembly and Disassembly Instructions

GENERAL CYLINDER DISASSEMBLY INSTRUCTIONS

Begin with a clean work area. Be sure all replacement parts are present and have no visual damage or defects. The following tools are recommended for proper disassembly and assembly.

- SAE Hex Wrench Set
- Metric Hex Wrench Set
- Torx bit set
- Metric Socket Set
- SAE Socket Set

1. **DUST BAND AND CARRIER REMOVAL.** Position the actuator with the Dust Band (21) facing up. Remove the Band Clamps (8) from both Heads (2) of the actuator by removing Screws (11) and backing out the Center Set Screw (10) a couple turns. Carefully lift the Dust Band (21) from the slot in each Head (2) and remove any Shims (29) located under the Band (21) in the Head (2) slot. Retain the Shims (29) for reassembly. Remove Screws (24) to release the Carrier (22) from the Nut Bracket Assembly (16). Slide the Carrier (22) clear of the Nut Bracket (16). Remove Nut Bracket End Caps (31) from both ends of the Nut Bracket (16). The Dust Band (21) can now be removed from the actuator.

NOTE: If removal of the Bearing Rail (27a) or Bearing Blocks (27b) is necessary, contact the factory prior to removal for specific instructions.

2. **LEADSCREW SUB-ASSY REMOVAL.** On the Non-Drive End of the actuator remove the Screws (14) and remove the Cover Plate (13) and the Hex Nut (12) from Leadscrew (15). Remove Screws (9) from both Heads (2). Remove the Non-Drive End Head (2) and the Drive Head/Leadscrew (15) assembly. If necessary, the Nut Bracket Assembly (16) can now be removed from the Leadscrew (15) and the Band Ramps (30) may also be removed from the Nut Bracket Assembly (16) if required.

Ball Nut style: Caution is required if removal of the Nut is necessary. Contact the factory for available parts and procedures.

Plastic Nut style: Plastic Nuts are factory pinned into the Nut Bracket (16) and cannot be removed. If Nuts are worn, a new Nut Bracket Assembly (16) must be ordered.

If Drive End Head (2) and Bearing (3) must be removed from the Leadscrew (15), contact the factory prior to removal for specific instructions.

GENERAL CYLINDER ASSEMBLY INSTRUCTIONS

1. **INSTALL LEADSCREW ASSEMBLY AND CARRIER.** Install the Band Ramps (30) to the Nut Bracket (16) with Screws (32). From the Drive End, install the Head/Leadscrew/Nut Bracket Assembly (16) into the Tube (1) making sure the Bearing Rail (27a) is oriented on the left side of the Tube (1). With the Bumper (19) and Nut Spacer (18) in place, position the Non-Drive End Head (2) over the Leadscrew Bearing (3) and loosely install Screws (9) into the Head (2). Install the Drive End Screws (9) loosely into the Drive End Head (2).

2. **INSTALL DUST BAND AND CARRIER.** Install the Dust Band (21) through the Nut Bracket (16) and install the End Caps (31) onto the Nut Bracket (16). Position Carrier (22) over the Bearing Blocks (27b) and the Nut Bracket (16) and install all Fasteners (24) and leave them loose at this time. By hand, load the Carrier (22) to keep it tight down on the surface of the Bearing Blocks (27b) and tighten the Carrier-to-Nut Bracket Fasteners (24). Tighten the Carrier-to-Bearing Block Fasteners (25).

3. **PERFORM HEAD ALIGNMENT AND FINAL ASSEMBLY.**

NOTE: Custom tooling is used at the factory to align the Heads (2) to the Tube (1) to maintain parallelism between the top of the Head (2) and top of the Tube (1). This is critical to performance and longevity of the Dust Band (21). In the following steps it will be necessary to measure parallelism between the Head (2) and the Tube (1).

Move Carrier Assembly (22) to Drive End of Tube (1) and tighten one of the Head Bolts (9). Support the actuator on the Tube (1) such that the Head (2) is free to float while tightening the Head Fasteners (9).

Move Carrier Assembly (22) to Non-Drive End of Tube (1) and tighten these Head Bolts (9).

Move Carrier Assembly (22) back to the Drive End of Tube (1) and loosen the Fastener (9) that was previously tightened and then tighten all Head Fasteners (9).

Apply Loctite 242 to Hex Nut (12) and thread onto the Leadscrew (15) and torque to 6-8 in-lbs. Install Cover Plate (13) with screws (14).

4. **INSTALL BAND CLAMPS.** Visually examine the interface between the Dust Band (21) surface of the Tube (1) and the clamping surface of each Head (2). This should be flush. It may be necessary to install Shims (29) in the pocket of the Head (2) in order to make flush. Position the Carrier (22) near the Drive End. Position the Band (21) in the pocket over any previously installed Shims (29) and install the Band Clamp (8) with the two Cap Screws (11). Lastly, tighten down the Center Set Screw (10). Position the Carrier (22) near the Non-Drive End and repeat the steps to install the other Band Clamp (8).

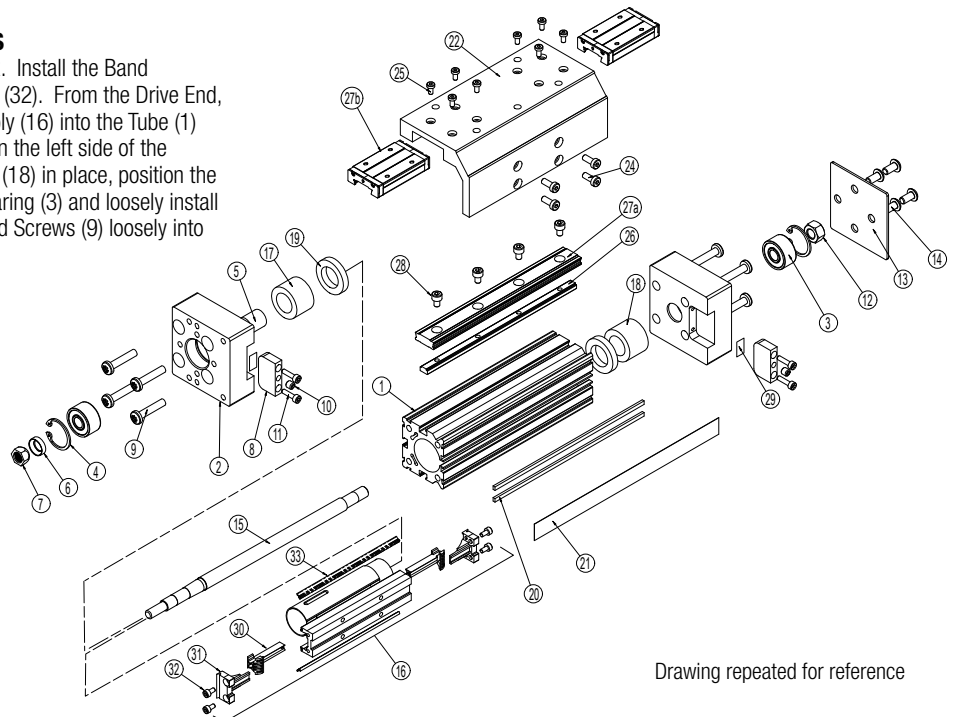

Drawing repeated for reference

Reverse Parallel (RP) Mounting Option

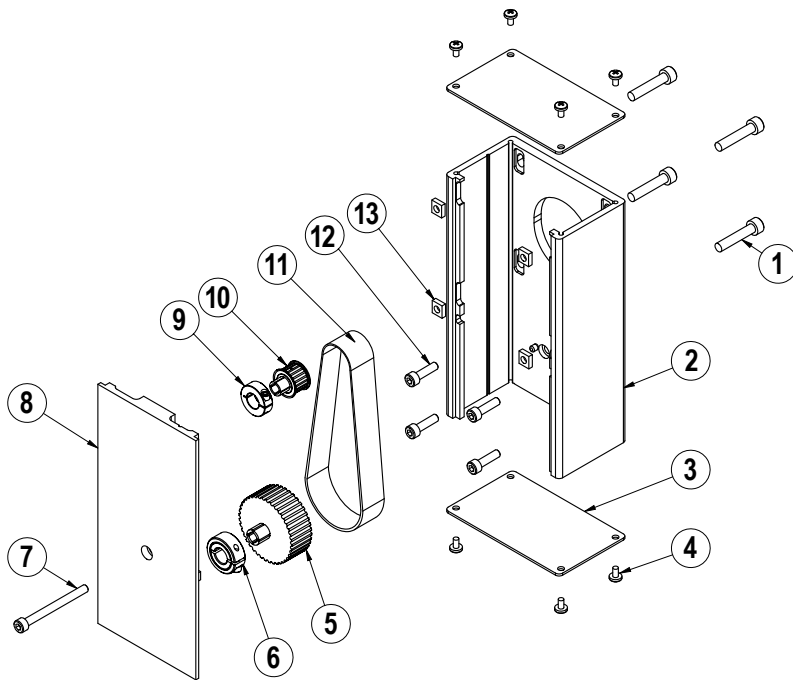

ITEM	PART NO.	DESCRIPTION	QTY.
◊1.	CONFIGURED	MOTOR FASTENER	4
◊2.	CONFIGURED	RP HOUSING	1
◊3.	CONFIGURED	RP HOUSING END CAP	2
◊4.	CONFIGURED	END CAP SCREW	8
◊5.	CONFIGURED	DRIVE SHAFT PULLEY	1
◊6.	CONFIGURED	COLLAR CLAMP, DRIVE SHAFT	1
◊7.	CONFIGURED	RP COVER FASTENER	1
◊8.	CONFIGURED	RP COVER	1
◊9.	CONFIGURED	COLLAR CLAMP, MOTOR	1
◊10.	CONFIGURED	MOTOR PULLEY	1
◊11.	CONFIGURED	BELT	1
◊12.	CONFIGURED	RP PLATE FASTENER	4
◊13.	CONFIGURED	SQUARE NUT	4

◊ Part numbers varies depending on YMH (Your Motor Here).
Contact help@tolomatic.com for replacement part numbers.

Disassembly Instructions

1. Remove End Caps (3), and release the tension on the Belt (11) by breaking loose the motor fasteners (1).
2. Remove the RP Cover (8).
3. The Belt (11) can now be removed along with the Motor.
4. Remove both Pulleys (10) and (5) from their respective shafts.
5. Remove the RP Housing (2) from the actuator head by removing the Fasteners (12).

Assembly Instructions

Note: Apply Loctite #242 to all fasteners upon installation

1. Install RP Housing (2) onto the actuator Head with Fasteners (12).
2. Install the Motor to the RP Housing with Fasteners (1) and Square Nuts (13). Do not tighten the fasteners at this time.
3. Locate the Belt (11) over the Pulleys (10) and (5) and slide both pulleys over their respective shafts. Tighten each pulley to its shaft with the Collar Clamps (9) and (6).
4. Position the Cover (8) in the mating slot of the RP case and install the Fasteners (7) to hold it in place. Take care not to overtighten. If the cover is deflected, it can interfere with the leadscrew.
5. Tension the Belt (11) by pulling the motor away from the drive shaft with the appropriate tension force shown in the chart below. While tensioning, the actuator should be positioned so the weight of the motor does not affect the belt tension. Tighten the Motor Fasteners (1) while the tensioning force is applied to the motor.

SMALLEST SHAFT DIAMETER (Motor or Actuator)		TOTAL WEIGHT TO APPLY	
Inches	mm	lbs	kgs
0.18 to 0.259	4.572 to 6.579	13	5.902
0.260 to 0.499	6.604 to 12.675	22	9.988
0.500 to 0.625	12.7 to 15.875	31	14.074
0.625 and larger	15.875 and larger	40	18.160

Additional tips are found in Tolomatic [Electric Actuator Motor Mounts Technical Note # 3600-4203](#).

6. Verify that there is clearance between the inside of the RP case and each pulley. Verify the pulleys are aligned to each other.
7. Install both End Caps (3) with the Screws (4) to finalize the assembly.

In-Line (LMI) Mounting Options

ITEM	PART NO.	DESCRIPTION	QTY
◊44.	CONFIGURED	MOTOR SPACER	1
◊45.	CONFIGURED	DOWEL PIN	2
◊46.	CONFIGURED	SCREW	4
◊47.	CONFIGURED	SCREW	4
◊48.	CONFIGURED	COVER	1
◊49.	CONFIGURED	CLAMP	1
◊50.	CONFIGURED	SCREW	1
◊51.	CONFIGURED	COUPLER	1

◊ Part number varies depending on YMH (Your Motor Here).
Contact help@tolomatic.com for replacement part number.

A replacement Motor Mount Kit contains all parts listed above.

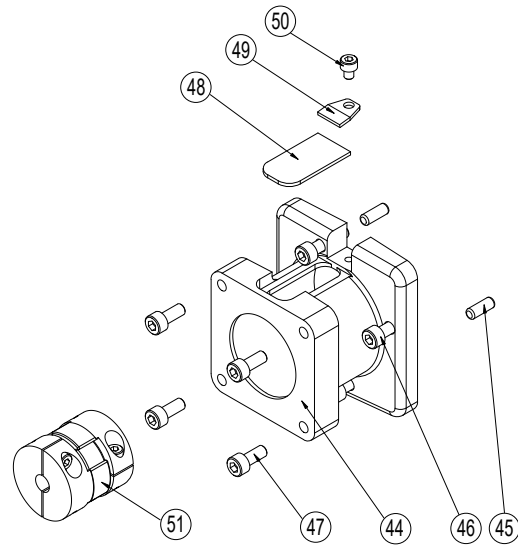

Replacement Motor Mount Kits ordering method: **MMK MXE25P** **LMI YM**

EXAMPLE: MMK MXE25P SN02 LMI YM 011001

Motor Mount Kit — Model & Size — Bearing Style — Lead Screw — Motor Orientation — Motor Code

Actuator Options Parts

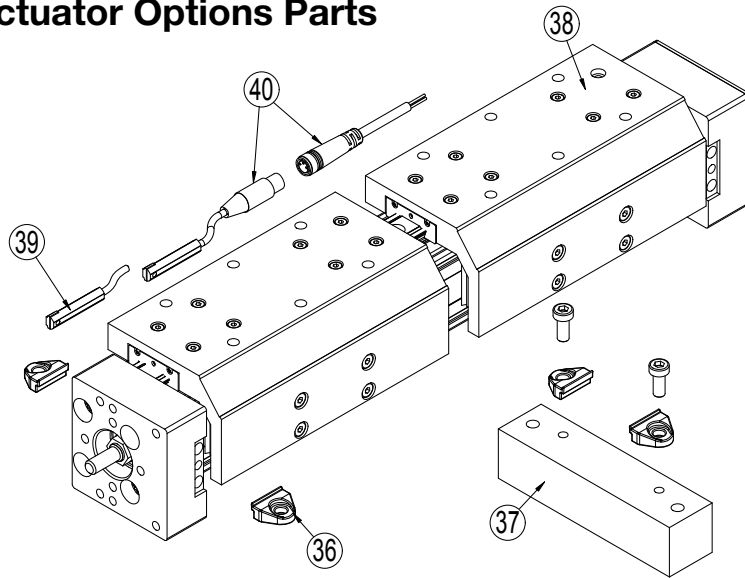

ITEM	PART NO.	DESCRIPTION
136.	8125-9018	TUBE CLAMP MOUNT KIT
	8125-1050	TUBE CLAMP
237.	8325-9016	MOUNTING PLATE KIT FOR 23-FRAME MOTOR
	8325-9017	MOUNTING PLATE KIT FOR 34-FRAME MOTOR
	8125-1050	TUBE CLAMP
	8125-1071	SCREW (METRIC)
	8325-1030	MOUNTING PLATE FOR 23-FRAME MOTOR
	8325-1031	MOUNTING PLATE FOR 34-FRAME MOTOR
38.	8325-9014	AUXILIARY CARRIER ASSY (METRIC)
	8325-9514	AUXILIARY CARRIER ASSY (INCH)

- ¹ Tube Clamp Mount Kit contains 2 tube clamps.
- ² Mounting Plate Kit contains 2 tube clamps, 1 mounting plate, and 2 fasteners

To order service parts switches:

Switches for MXE include retained mounting hardware and are the same for all actuator sizes and bearing styles

ITEM	CONFIG. CODE	LEAD	NOR-MALLY	SENSOR TYPE
39.	SWMXE25P R Y	5M (197 IN)	OPEN	REED
40.	SWMXE25P R K	QUICK-DISCONNECT		
39.	SWMXE25P N Y	5M (197 IN)	CLOSED	REED
40.	SWMXE25P N K	QUICK-DISCONNECT		
39.	SWMXE25P T Y	5M (197 IN)	OPEN	SOLID STATE PNP
40.	SWMXE25P T K	QUICK-DISCONNECT		
39.	SWMXE25P K Y	5M (197 IN)	OPEN	SOLID STATE NPN
40.	SWMXE25P K K	QUICK-DISCONNECT		
39.	SWMXE25P P Y	5M (197 IN)	CLOSED	SOLID STATE PNP
40.	SWMXE25P P K	QUICK-DISCONNECT		
39.	SWMXE25P H Y	5M (197 IN)	CLOSED	SOLID STATE NPN
40.	SWMXE25P H K	QUICK-DISCONNECT		

MATING QD CABLE IS INCLUDED.

Ordering Repair Kits

Repair kit includes: dust band, end caps, wipers, solid bearings, bearing end caps
 The part number for a repair kit begins with RK followed by model, actuator size, bearing type, and stroke length (**S****RK** = inch/US Standard, **S****M**= metric)
 (NOTE: If unit has an auxiliary carrier also include DC and distance between carrier centers)

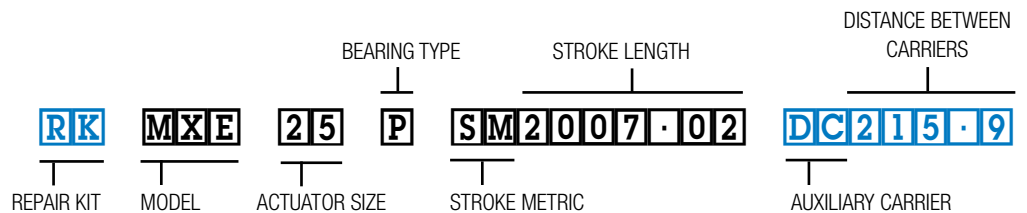

SWITCH WIRING DIAGRAMS AND LABEL COLOR CODING (CE and RoHS Compliant)

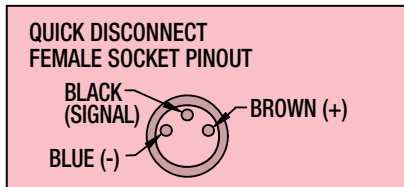
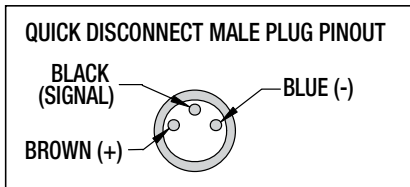
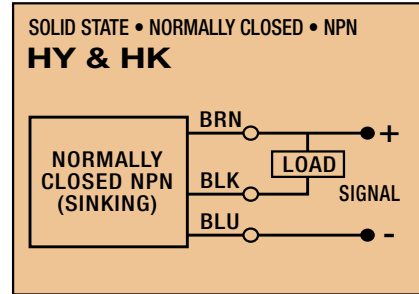
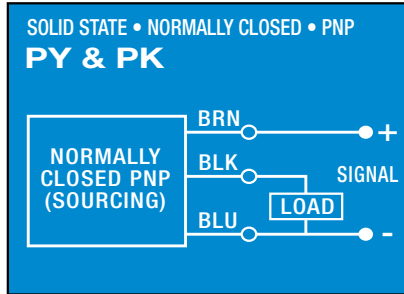
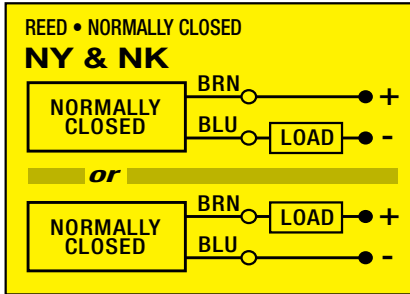
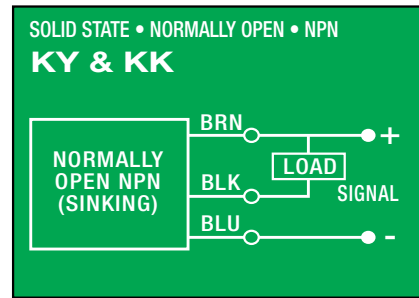
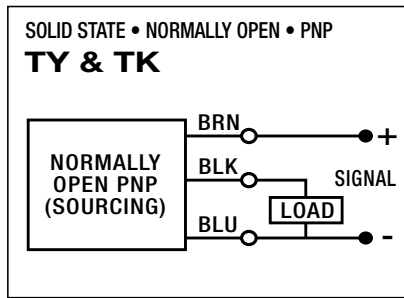
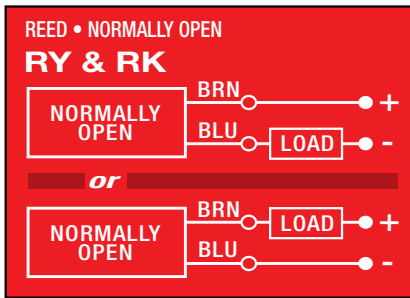

- Switches for MX:
- Include retained mounting hardware
 - In slot, sit below extrusion profile
 - Same for all sizes and bearing styles

Switch installation and replacement

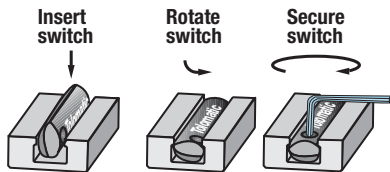

Place switch in side groove on tube at desired location with "Tolomatic" facing outward. While applying light pressure to the switch, rotate it such that the switch is halfway in the groove. Maintaining light pressure, rotate the switch in the opposite direction until the switch is fully inside the groove with "Tolomatic" visible. Re-position the switch to the exact location and lock the switch securely into place by tightening the screw on the switch.

Switch Detection point

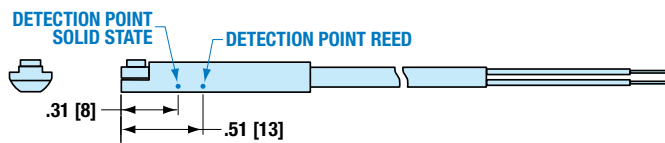

Dimensions in inches [brackets indicate dimensions in millimeters]



3800 County Road 116, Hamel, MN 55340 USA
<http://www.Tolomatic.com> • Email: Help@Tolomatic.com
 Phone: (763) 478-8000 • Fax: (763) 478-8080 • Toll Free: 1-800-328-2174

COMPANY WITH
 QUALITY SYSTEM
 CERTIFIED BY DNV
 = ISO 9001 =

All brand and product names are trademarks or registered trademarks of their respective owners. Information in this document is believed accurate at time of printing. However, Tolomatic assumes no responsibility for its use or for any errors that may appear in this document. Tolomatic reserves the right to change the design or operation of the equipment described herein and any associated motion products without notice. Information in this document is subject to change without notice.