

MXE32S Solid Bearing Screw-Drive Actuators

32mm (1-1/4 inch) Series

Models: MXE32SBN08 MXE32SBNL08 MXE32SSN01
 MXE32SSN02 MXE32SSN05

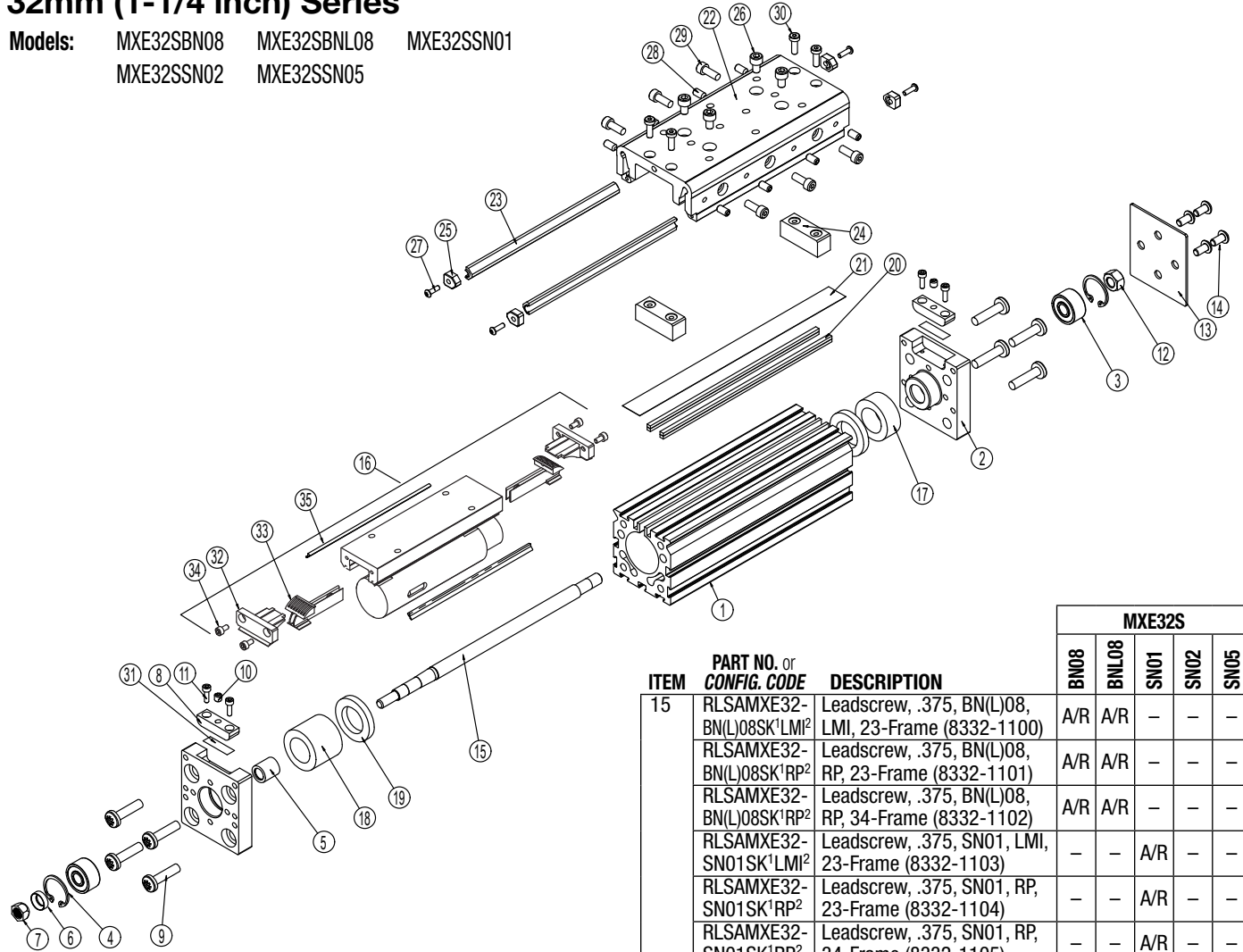

Parts Listing

A/R= As Required

ITEM	PART NO. or CONFIG. CODE	DESCRIPTION	MXE32S				
			BN08	BNL08	SN01	SN02	SN05
1 ¹	RTBMXE32	Replacement Tube (8332-1010)	A/R	A/R	A/R	A/R	A/R
2	8332-1011	Head	2	2	2	2	2
3	4510-1060	Bearing	2	2	2	2	2
4	3410-1207	Retaining Ring	2	2	2	2	2
5	3410-2041	Sleeve	1	1	1	1	1
6	3410-2014	Washer	1	1	1	1	1
7	3410-2013	Lock Nut	1	1	1	1	1
8	8332-1017	Band Clamp	2	2	2	2	2
9	0604-1025	Screw	8	8	8	8	8
10	0601-1093	Set Screw	2	2	2	2	2
11	0602-3012	Screw	4	4	4	4	4
12	0701-1059	Lock Nut	1	1	1	1	1
13	8332-1022	Cover Plate	1	1	1	1	1
14	0110-1424	Screw	4	4	4	4	4

ITEM	PART NO. or CONFIG. CODE	DESCRIPTION	MXE32S				
			BN08	BNL08	SN01	SN02	SN05
15	RLSAMXE32-BN(L)08SK ¹ LMI ²	Leadscrew, .375, BN(L)08, LMI, 23-Frame (8332-1100)	A/R	A/R	-	-	-
	RLSAMXE32-BN(L)08SK ¹ RP ²	Leadscrew, .375, BN(L)08, RP, 23-Frame (8332-1101)	A/R	A/R	-	-	-
	RLSAMXE32-BN(L)08SK ¹ RP ²	Leadscrew, .375, BN(L)08, RP, 34-Frame (8332-1102)	A/R	A/R	-	-	-
	RLSAMXE32-SN01SK ¹ LMI ²	Leadscrew, .375, SN01, LMI, 23-Frame (8332-1103)	-	-	A/R	-	-
	RLSAMXE32-SN01SK ¹ RP ²	Leadscrew, .375, SN01, RP, 23-Frame (8332-1104)	-	-	A/R	-	-
	RLSAMXE32-SN01SK ¹ RP ²	Leadscrew, .375, SN01, RP, 34-Frame (8332-1105)	-	-	A/R	-	-
	RLSAMXE32-SN02SK ¹ LMI ²	Leadscrew, .375, SN02, LMI, 23-Frame (8332-1106)	-	-	-	A/R	-
	RLSAMXE32-SN02SK ¹ RP ²	Leadscrew, .375, SN02, RP, 23-Frame (8332-1107)	-	-	-	A/R	-
	RLSAMXE32-SN02SK ¹ RP ²	Leadscrew, .375, SN02, RP, 34-Frame (8332-1108)	-	-	-	A/R	-
	RLSAMXE32-SN05SK ¹ LMI ²	Leadscrew, .375, SN05, LMI, 23-Frame (8332-1117)	-	-	-	-	A/R
16 ³	8332-90061	Nut Bracket Assy, SN01	-	-	1	-	-
	8332-90071	Nut Bracket Assy, SN02	-	-	-	1	-
	8332-90081	Nut Bracket Assy, SN05	-	-	-	-	1
	8332-9009	Nut Bracket Assy, BN08	1	1	-	-	-

¹ SK or SM ____, indicate stroke length in inches or millimeters

² Length of connecting shaft varies by motor type and size, indicate motor code here

³ Solid Nut Bracket Assembly available to order for replacement. Contact the Factory.

⁴ Parts included in Nut Bracket Assembly.

⁵ Parts included in Repair Kits. (RKMXE32SSK or SM ____, indicate stroke length in inches or millimeters)

Parts Listing Continued

A/R= As Required

Drawing repeated for reference

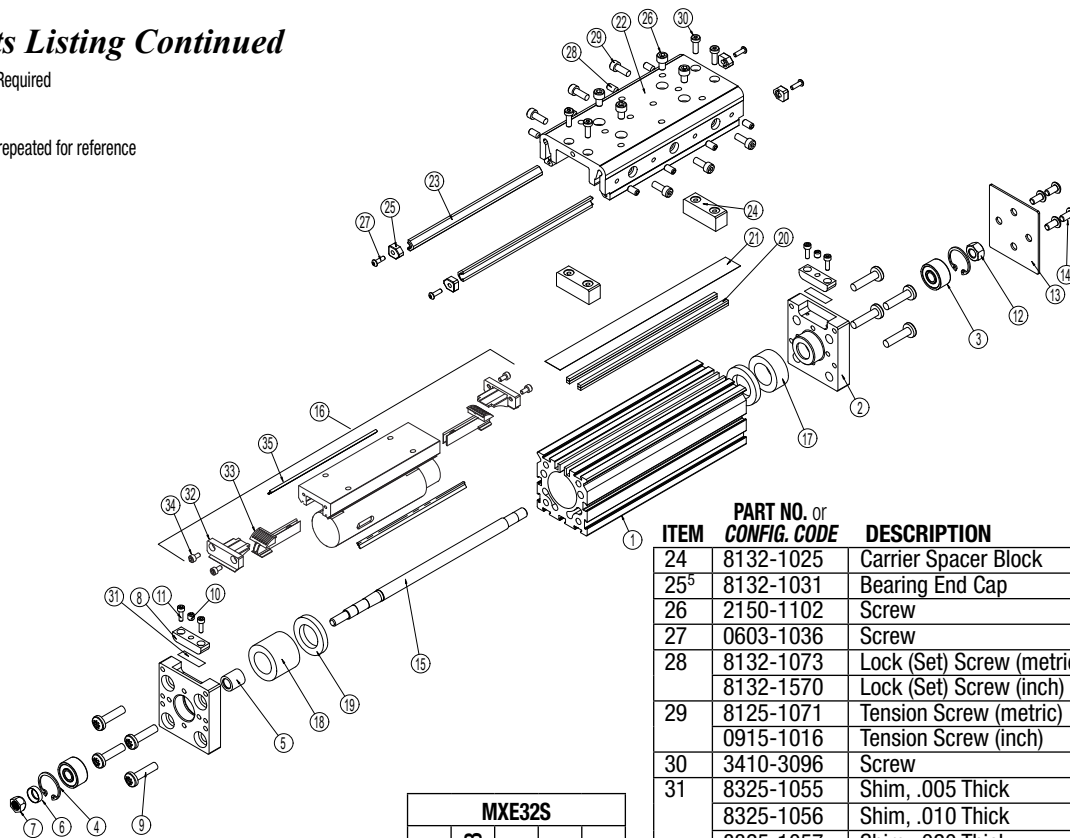

ITEM	PART NO. or CONFIG. CODE	DESCRIPTION	MXE32S				
			BN08	BNL08	SN01	SN02	SN05
17	8332-1025	Spacer	1	1	1	1	1
	8332-1026	Solid Nut Spacer			1	1	1
18	8332-1024	Ball Nut Spacer	1	1			
19	8332-1023	Bumper	2	2	2	2	2
20	NMBMXE32	New Magnet Band Kit (8332-1019) (4 magnet strips included)	After Config. Code add: SK (stroke length in inches) or SM (stroke length in mm)				
21 ⁵	NDBMXE32	New Dust Band (8332-1018)					
22	8332-1013	Carrier (metric)	1	1	1	1	1
	8332-1513	Carrier (inch)	1	1	1	1	1
23 ⁵	8132-1030	Plain Bearing	2	2	2	2	2

ITEM	PART NO. or CONFIG. CODE	DESCRIPTION	MXE32S				
			BN08	BNL08	SN01	SN02	SN05
24	8132-1025	Carrier Spacer Block	2	2	2	2	2
25 ⁵	8132-1031	Bearing End Cap	4	4	4	4	4
26	2150-1102	Screw	4	4	4	4	4
27	0603-1036	Screw	4	4	4	4	4
28	8132-1073	Lock (Set) Screw (metric)	8	8	8	8	8
	8132-1570	Lock (Set) Screw (inch)	8	8	8	8	8
29	8125-1071	Tension Screw (metric)	6	6	6	6	6
	0915-1016	Tension Screw (inch)	6	6	6	6	6
30	3410-3096	Screw	4	4	4	4	4
	8325-1055	Shim, .005 Thick	2	2	2	2	2
	8325-1056	Shim, .010 Thick	2	2	2	2	2
	8325-1057	Shim, .020 Thick	2	2	2	2	2
32 ^{4,5}	8132-1006	End Cap	2	2	2	2	2
33 ^{4,5}	8332-1007	Band Ramp	2	2	2	2	2
34 ⁴	0601-1038	Screw	4	4	4	4	4
35 ⁵	8132-1059	Wiper	2	2	2	2	2

Assembly and Disassembly Instructions

GENERAL CYLINDER DISASSEMBLY INSTRUCTIONS

Begin with a clean work area. Be sure all replacement parts are present and have no visual damage or defects. The following tools are recommended for proper disassembly and assembly.

- SAE Hex Wrench Set
- Metric Hex Wrench Set
- Torx bit set
- Metric Socket Set
- SAE Socket Set

1. **DUST BAND AND CARRIER REMOVAL.** Remove the Band Clamps (8) from both Heads (2) of the actuator by removing Screws (11) and backing out the Center Set Screw (10) a couple turns. Carefully lift the Dust Band (21) from the slot in each Head (2) and remove any Shims (31) located under the band in the Head slot. Retain the Shims (31) for reassembly. Remove the Carrier Spacer Blocks (24). Remove Screws (26) from the Carrier (22). Remove End Caps (32) from both ends of the Nut Bracket (16). The Dust Band (21) can now be removed from the actuator. Slightly loosen the Carrier Tension

Screws (29) and Lock (Set) Screws (28). Remove Bearing End Caps (25) from the Bearings (23) and slide the Bearings (23) out. The Carrier (22) can now be removed.

NOTE: If the stroke of the actuator is too short to allow removal of the Carrier Bearings (23), it is necessary to remove the Non-Drive End Head (2) from the Tube (1).

2. **LEADSCREW SUB-ASSY REMOVAL.** On the Non-Drive End of the actuator, remove Screws (14) to remove the Cover Plate (13), and Hex Nut (12) from the Leadscrew (15). Remove Screws (9) from both Heads (2). Remove the Non-Drive End Head (2) and the Drive Head/Leadscrew Assembly. The Nut Bracket Assembly (16) can now be removed from the Leadscrew (15) if necessary and the Band Ramps (33) may also be removed from the Nut Bracket Assembly (16) if required.

Ball Nut style: Caution is required if removal of the Nut is necessary. Contact the factory for available parts and procedures.

Plastic Nut style: Plastic Nuts are factory pinned into the Nut Bracket (16) and cannot be removed. If Nuts are worn, a new Nut Bracket Assy (16) must be ordered.

If the Drive End Head (2) and Bearing (3) must be removed from the Leadscrew (15), contact the factory prior to removal for specific instructions.

GENERAL CYLINDER ASSEMBLY INSTRUCTIONS

1. SUB-ASSEMBLE CARRIER. Slide the Bearings (23) into the slots on the Carrier (22) and install Bearing End Caps (25) loosely onto the Bearing Ends with Screws (27). Keep the Tension Screws (29) and Lock (Set) Screws (28) loose. If removed, install the Band Ramps (20) to the Nut Bracket (16).

2. INSTALL LEADSCREW ASSEMBLY.

Install the Drive Head/Leadscrew assembly into the Tube (1). Ensure that the Bumper (19) and Nut Spacer (18) are in place and position the Non-Drive End Head (2) over the Leadscrew Bearing (3) and loosely install Screws (9) into the Head (2). Install the Drive End Screws (9) loosely into the Head (2).

3. INSTALL DUST BAND AND CARRIER. Install the Dust Band (21) through the Nut Bracket (16) and install End Caps (21) onto the Nut Bracket (16). Position Carrier sub-assembly onto the Tube (1).

4. TENSION THE CARRIER. The MX solid bearing carrier will provide best performance when properly adjusted. The carrier design contains both Tension (29) and Lock Screws (28). The Tension Screws (29) control the amount of pressure placed on the Carrier Bearings (23). The Lock Screws (28) lock the Tension Screws (29) in place and provide fine adjustment of the Carrier Bearings (23).

- a. Fully loosen all Tension (29) and Lock Screws (28) about 1/2 of a turn so that they are not engaged with the Bearing (23).
- b. Tighten Tension Screws (29) on both sides of the Carrier (22) roughly 1/8 to 1/4 turn clockwise past where the Screw (29) starts to feel snug. The Carrier (22) should be very difficult or impossible to move by hand. If not, turn another 1/8 turn until it is difficult to move.
- c. Next, adjust the Lock Screws (28) on both sides of the Carrier (22) roughly 1/8 to 1/4 turn clockwise past where the Screw (28) starts to engage. The Carrier (22) will be loose but should not rock sideways. To correct this, loosen the Lock Screws (28) about 1/16 of a turn. If the Carrier (22) becomes too snug, adjust the Lock Screws (28) another 1/8 of a turn.
- d. Ideal carrier tension is achieved when the Carrier (22) feels snug in relation to the Tube (1), yet can be moved by hand. No rocking motion should be present. The Carrier (22) should also be loose enough to be moved by hand over the entire length of the actuator. If after this process the Carrier (22) has become too loose, equally adjust all of the Lock Screws (28) with a slight 1/32 turn counter-clockwise.

During the service life of the application this process may need to be repeated. Keeping the Carrier (22) in a properly adjusted tension will prolong the life of the MX bearing system and the actuator itself.

- e. When the proper carrier tension has been achieved, finish tightening the four Screws (34) to the Bearing End Caps (32).

- f. Position the Carrier (22) over the Nut Bracket (16) and install Screws (26). Install the Carrier Spacer Blocks (24) to the Carrier (22).

5. PERFORM HEAD ALIGNMENT AND FINAL ASSEMBLY.

NOTE: Custom tooling is used at the factory to align the Heads (2) to the Tube (1) to maintain parallelism between the top of the Head (2) and top of the Tube (1). This is critical to performance and longevity of the Dust Band (21). In the following steps take care to visually align Head (2) to Tube (1).

Move the assembled Carrier (22) to the Drive End of Tube (1) and tighten one of the Head Bolts (9). Support the actuator so the Head (2) is free to float while tightening the Screws (9). Move the Carrier Assy (22) to Non-Drive End of Tube (1) and tighten the Head Bolts (9). Move Carrier Assy (22) back to the Drive End of Tube (1) and loosen the Screw (9) that was previously tightened and then tighten all Head Fasteners (9). Apply Loctite 242 to Hex Nut (12) and thread onto the Leadscrew (15) and torque to 6-8 in-lbs. Install Cover Plate (13) with Screws (14).

6. INSTALL BAND CLAMPS. The Dust Band (21), Tube (1) and clamping surface of the Head (2) must be flush with each other. To accommodate this, it may be necessary to re-install any Shims (31) that were present

during disassembly into the clamp pocket on the Head (2). Position the Carrier (22) near the Drive End and position the Band (21) in the pocket over the installed Shims (31) and install the Band Clamp (8) with the two Screws (11). Tighten down the Center Set Screw (10). Position the Carrier (22) near the Non-Drive End and repeat the steps to install the other Band Clamp (8).

Check out our MX--S carrier adjustment video on the web
<https://youtu.be/LWWPg2gfy0A>

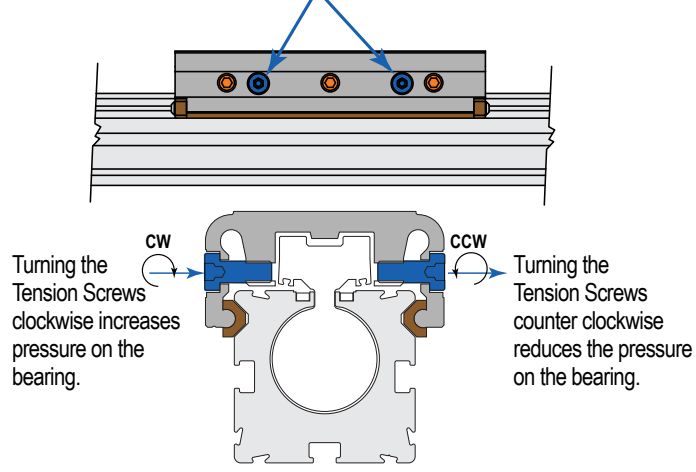
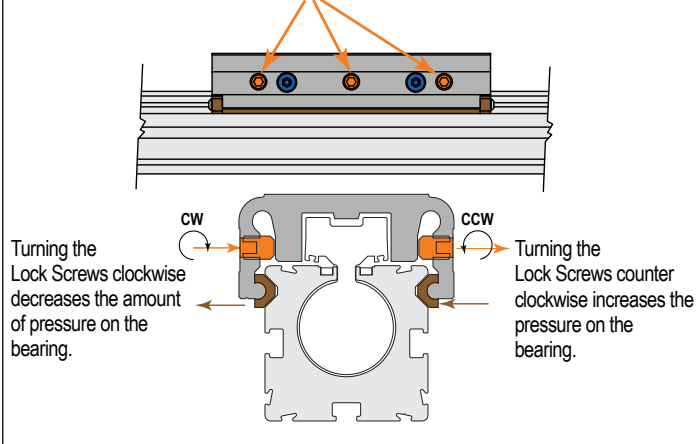
TENSION SCREWS**LOCK SCREWS**

Reverse Parallel Options Parts

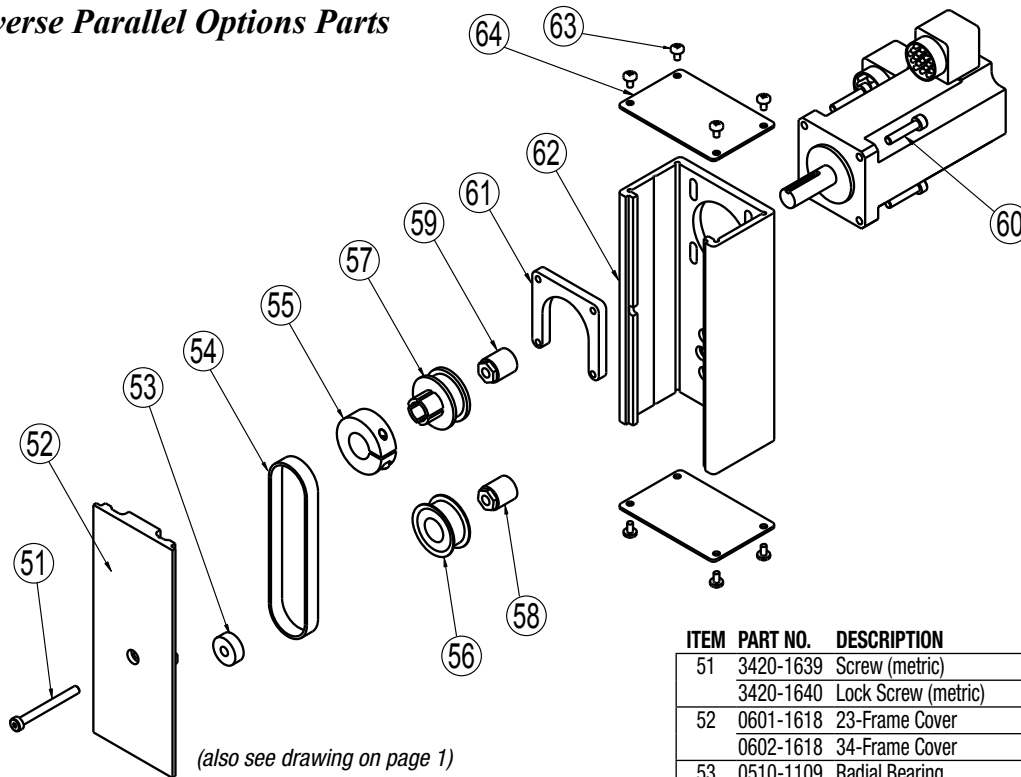

REVERSE PARALLEL DISASSEMBLY INSTRUCTIONS

1. Remove Screws (63) to release Housing End Caps (64). Release the tension on Belt (54) by breaking loose the Motor Screws (60).
2. Remove Screw (51) to remove Cover (52).
3. The Belt (54) can now be removed along with the Motor.
4. Remove both Pulleys (56) and (57) from their respective shafts.
5. Remove the RP Housing (62) from the actuator Head (2) by removing the Head Screws (9) from the RP Housing (62).

REVERSE PARALLEL ASSEMBLY INSTRUCTIONS

NOTE: Apply Loctite #242 to all screws upon installation

1. Install RP Housing (62) to the actuator Head with Screws (9). Do not fully tighten the Fasteners (9) at this time and verify that the RP Housing (62) can move with respect to the Head (2).
2. Temporarily install the Cover (52) with Bearing (53), onto the RP Housing (62) positioning the Bearing (53) over the Leadscrew (15) shaft. Hold the Cover (52) in place while tightening two of the Screws (9) that hold the RP Housing (62) to the actuator Head (2).
3. Remove the Cover (52) and finish tightening all Screws (9) attaching the RP Housing (62) to the Head (2).
4. Install the Motor to the RP Housing (62) with Screws (60). Do not tighten the Screws (60) at this time.
5. Install Pulleys (56) and (57) as needed. Tighten each Pulley (56 & 57) to its shaft with either a Trantorque (58 or 59) or a Collar Clamp (55). If using a Trantorque (58 or 59), apply 75 in-lbs of torque with a torque wrench.
6. Locate the Belt (54) over the Pulleys (56) and (57).
7. Verify that there is clearance between the inside of the RP Housing (62) and each Pulley (56 & 57). Verify that the Pulleys (56 & 57) are aligned with each other.

ITEM	PART NO.	DESCRIPTION	1:1 RATIO				2:1 RATIO					
			MRV2x	MRS2x	MRS31,32	MRS33	MRV2x	MRS2x	MRS31,32	MRS33		
51	3420-1639	Screw (metric)			1	1						
	3420-1640	Lock Screw (metric)	1	1			1	1				
52	0601-1618	23-Frame Cover	1	1			1	1				
	0602-1618	34-Frame Cover			1	1			1	1		
53	0510-1109	Radial Bearing	1	1	1	1	1	1	1	1	1	1
54	0510-1112	Timing Belt	1	1	1	1						
	0510-1113	Timing Belt					1	1	1	1		
55	3420-1627	Clamp Collar				1						1
	0520-1067	Clamp Collar	1		1		1			1		
56	0515-1191	Pulley	1	1	1	1						
	0510-1110	Pulley					1	1	1	1		
57	0510-1398	Pulley				1						1
	3420-1255	Pulley	1		1		1			1		
	0515-1191	Pulley		1				1				
58	0510-1111	Trantorq, .250 Bore	1	1	1	1	1	1	1	1	1	1
59	0510-1111	Trantorq, .250 Bore		1				1				
60	2212-1099	Screw (metric)	4	4	4	4	4	4	4	4	4	4
61	0601-1053	23-Frame Motor Plate	1	1			1	1				
	0602-1057	34-Frame Motor Plate			1	1				1	1	
62	0601-1608	23-Frame Housing	1	1			1	1				
	0602-1608	34-Frame Housing			1	1				1	1	
63	0601-1625	Self-Tapping Screw	8	8	8	8	8	8	8	8	8	8
64	0601-1602	Housing End Cap, 23-Frame	2	2			2	2				
	0602-1602	Housing End Cap, 34-Frame			2	2			2	2		

8. Position the Cover (52) in the mating slot of the RP Housing (62) and install the Screw (51) to hold in place. Take care not to over tighten. If the Cover (52) is deflected it can interfere with the Leadscrew (15).
9. Tension the Belt (54) by pulling the Motor away from the drive shaft with the appropriate tension force shown in the chart below. While tensioning, the actuator should be positioned so the weight of the Motor does not affect the belt tension. Tighten the Motor Screws (60) while the tensioning force is applied to the Motor.

Smallest Shaft Diameter	Tension Force
.18" to .25"	10 lbs
> .25" to .50"	20 lbs
> .50"	30 lbs

*The smaller of the actuator drive shaft or the motor shaft.

10. Install both End Caps (64) with the Screws (63) to finalize assembly.

In-Line Mounting Options Parts

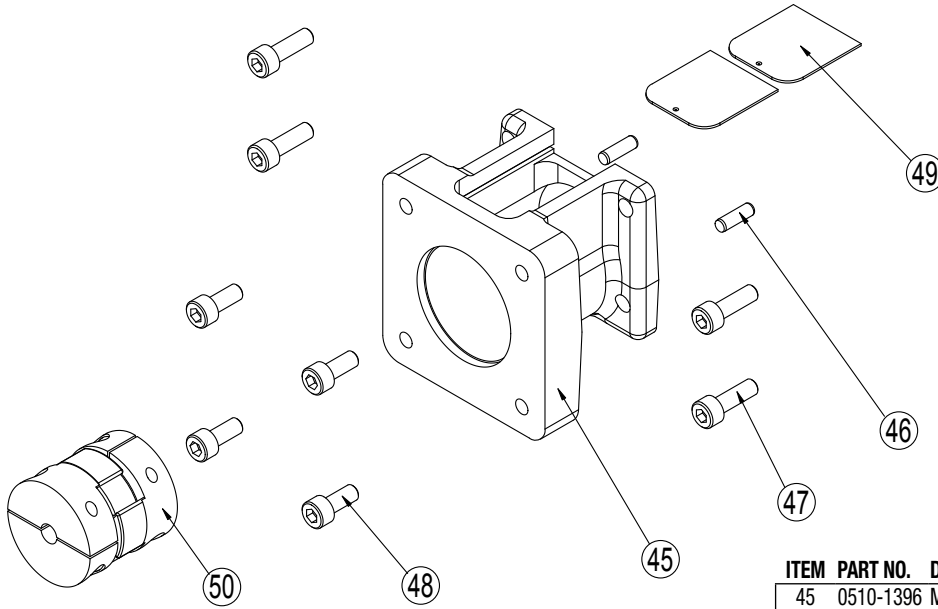

ITEM	PART NO.	DESCRIPTION	With Gearhead							
			MRV2x	MRV2x, SN01	MRS2x	MRS31,32	MRS33	MRV2x, MRS2x	MRS31, MRS32	MRS33
45	0510-1396	Motor Spacer			1					
	0510-1397	Motor Spacer				1	1		1	1
	4410-1350	Motor Spacer	1	1						
	4410-1352	Motor Spacer						1		
46	1930-1024	Dowel Pin	2	2	2	2	2	2	2	2
	4415-1016	Screw (metric)			4	4	4		4	4
47	1124-1035	Screw (metric)	4	4				4		
	4910-1004	Screw (metric)			4					
48	1124-1035	Screw (metric)				4	4	4	4	4
	4415-1022	Screw (metric)	4	4						
	4310-1103	Covers	2	2	2	2	2	2	2	2
50	3410-9039	Coupler			1					
	3600-6163	Coupler	1							
	3600-9213	Coupler		1		1		1	1	
	4510-9056	Coupler					1			1

Actuator Options Parts

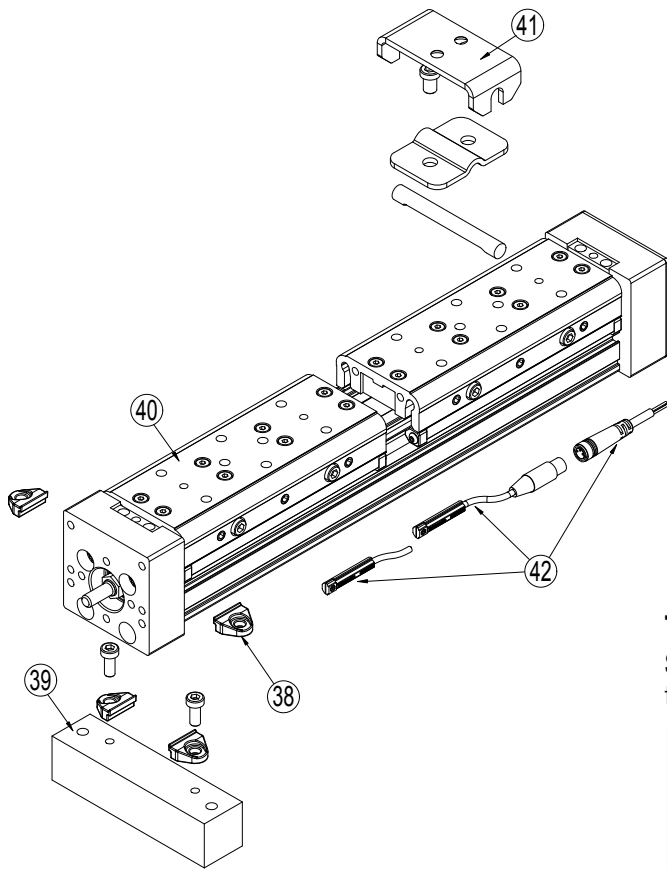

ITEM	PART NO.	DESCRIPTION
38 ¹	8132-9018	Tube Clamp Mount Kit
	8132-1050	Tube Clamp
39 ²	8332-9016	Mounting Plate Kit for 23-Frame Motor
	8332-9017	Mounting Plate Kit for 34-Frame Motor
	8132-1050	Tube Clamp
	2212-1031	Screw (metric)
40	8332-9015	Mounting Plate for 23-Frame Motor
	8332-1031	Mounting Plate for 34-Frame Motor
	8332-9015	Auxiliary Carrier Assy (metric)
41 ³	8332-9515	Auxiliary Carrier Assy (inch)
	8132-9036	Floating Mount Kit (metric)
	8132-9536	Floating Mount Kit (inch)
	8132-1069	Floating Mount Pin
	0912-1031	Floating Mount Clamp
	8132-1561	Floating Mount Bracket Clamp (inch)
	8132-1068	Floating Mount Bracket
	8132-1074	Screw (metric)
0920-1084	Screw (inch)	

¹ Tube Clip Kit contains 2 tube clamps.
² Mounting Plate Kit contains 2 tube clamps, 2 fasteners and 1 mounting plate.
³ Floating Mount Kit contains 1 pin, 1 bracket clamp, 1 bracket, and 2 fasteners.

TO ORDER SERVICE PARTS SWITCHES:

Switches for MXE include retained mounting hardware and are the same for all actuator sizes and bearing styles

ITEM	Config. Code	Lead	Normally	Sensor Type
42	SWMXE32S R Y	5m (197 in)	Open	Reed
	SWMXE32S R K	Quick-disconnect		
	SWMXE32S N Y	5m (197 in)	Closed	Reed
	SWMXE32S N K	Quick-disconnect		
	SWMXE32S T Y	5m (197 in)	Open	Solid State PNP
	SWMXE32S T K	Quick-disconnect		
	SWMXE32S K Y	5m (197 in)	Open	Solid State NPN
	SWMXE32S K K	Quick-disconnect		
	SWMXE32S P Y	5m (197 in)	Closed	Solid State PNP
	SWMXE32S P K	Quick-disconnect		
	SWMXE32S H Y	5m (197 in)	Closed	Solid State NPN
	SWMXE32S H K	Quick-disconnect		

Mating QD cable is included.

ORDERING REPAIR KITS

Repair kit includes: dust band, end caps, wipers, solid bearings, bearing end caps

The part number for a repair kit begins with RK followed by model, actuator size, bearing type, and stroke length (S**K** = inch/US Standard, S**M** = metric) (NOTE: If unit has an auxiliary carrier also include DC and distance between carrier centers)

REPAIR KIT	MODEL	ACTUATOR SIZE	BEARING TYPE	STROKE METRIC	STROKE LENGTH	AUXILIARY CARRIER	DISTANCE BETWEEN CARRIERS
RK	MXE	32	S	SM	2007	02	DC215.9

SWITCH WIRING DIAGRAMS AND LABEL COLOR CODING (CE and RoHS Compliant)

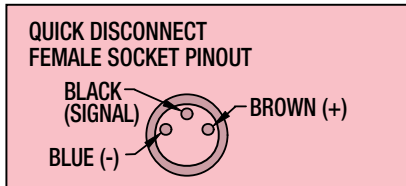
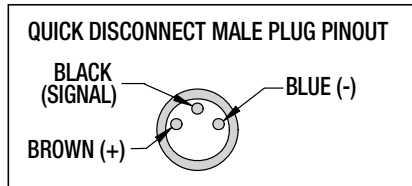
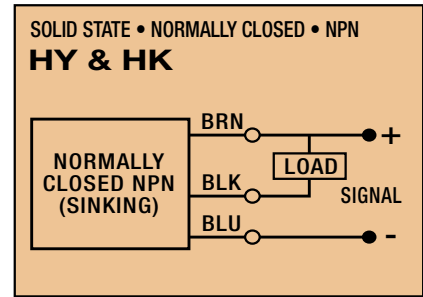
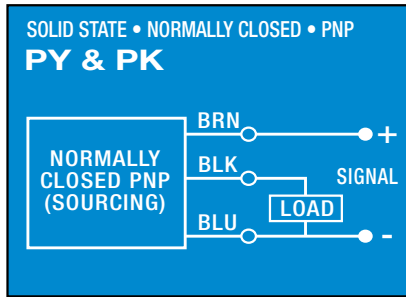
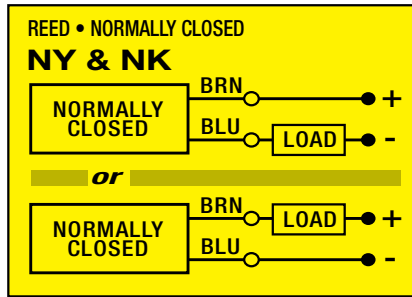
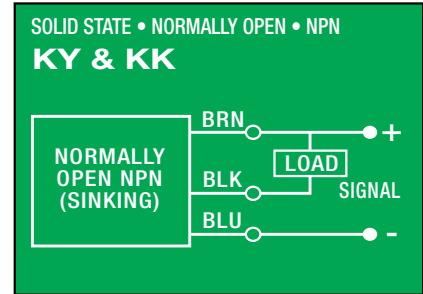
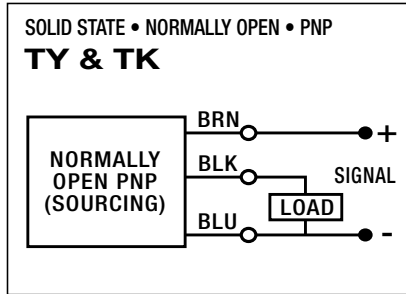
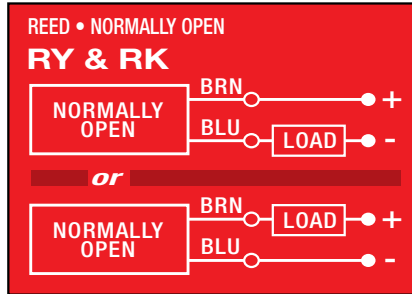

Switches for MX:

- Include retained mounting hardware
- In slot, sit below extrusion profile
- Same for all sizes and bearing styles

SWITCH INSTALLATION AND REPLACEMENT

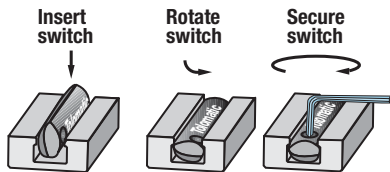

Place switch in side groove on tube at desired location with "Tolomatic" facing outward. While applying light pressure to the switch, rotate it such that the switch is halfway in the groove. Maintaining light pressure, rotate the switch in the opposite direction until the switch is fully inside the groove with "Tolomatic" visible. Re-position the switch to the exact location and lock the switch securely into place by tightening the screw on the switch.

SWITCH DETECTION POINT

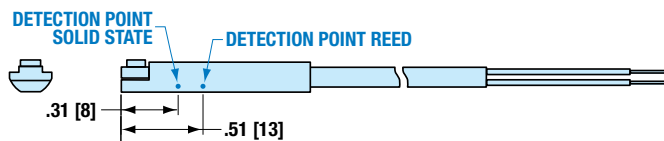

Dimensions in inches [brackets indicate dimensions in millimeters]



3800 County Road 116, Hamel, MN 55340 USA
<http://www.Tolomatic.com> • Email: Help@Tolomatic.com
 Phone: (763) 478-8000 • Fax: (763) 478-8080 • Toll Free: 1-800-328-2174

COMPANY WITH
 QUALITY SYSTEM
 CERTIFIED BY DNV GL
 = ISO 9001 =

All brand and product names are trademarks or registered trademarks of their respective owners. Information in this document is believed accurate at time of printing. However, Tolomatic assumes no responsibility for its use or for any errors that may appear in this document. Tolomatic reserves the right to change the design or operation of the equipment described herein and any associated motion products without notice. Information in this document is subject to change without notice.