



**OBSOLETE: EFFECTIVE JANUARY 1, 2020**

### 175x2 QCII Caliper Disc Brake Hydraulic Brake Retractable Piston, Aluminum Housing

**MODELS AVAILABLE:**

- 175 x 2 QCII Unspaced
- 3030-0004 No Linings
- 3030-0104 Soft Linings
- 3030-0204 Hard Linings

- 175 x 2 QCII Spaced
- 3030-0006 No Linings
- 3030-0106 Soft Linings
- 3030-0206 Hard Linings

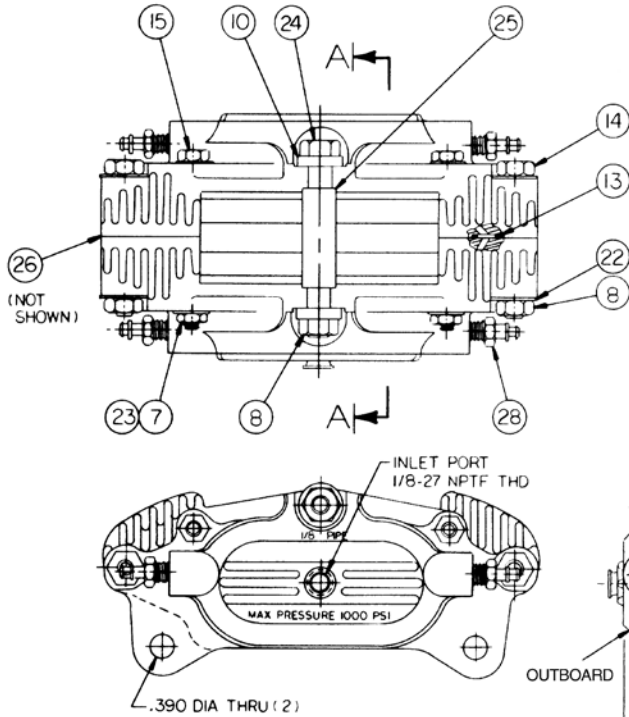

**(1-1-2020)  
DISCONTINUED  
PRODUCT STYLE OR  
SIZE. PARTS SHEET  
IS FOR REPAIR  
INSTRUCTIONS ONLY.**

Parts listing is for reference only. All parts listed are limited to stock on hand. Contact Tolomatic regarding availability.

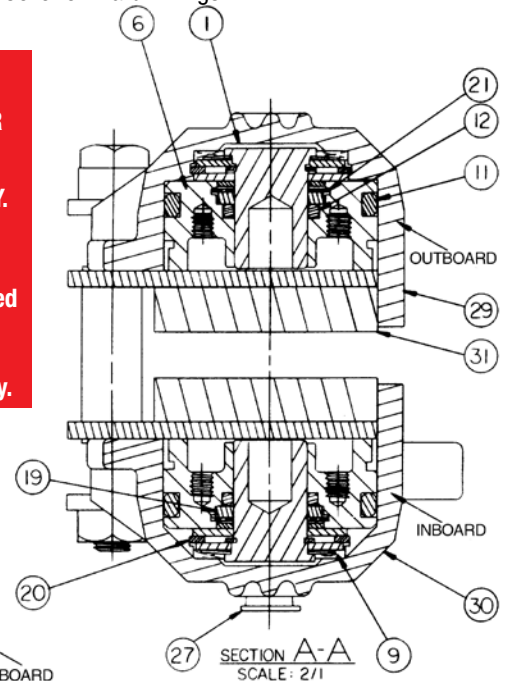

ITEM	PART NO.	DESCRIPTION	Quantity					
			3030-0004	3030-0104	3030-0204	3030-0006	3030-0106	3030-0206
1.	3025-9000	Retractor Body Subassembly	4	4	4	4	4	4
*2.	3010-1003	Flat Washer	4	4	4	4	4	4
*3.	3005-1004	Retaining Ring	4	4	4	4	4	4
*4.	3010-1001	Retractor Body	4	4	4	4	4	4
*5.	3010-1002	Belleville Spring Washer	4	4	4	4	4	4
6.	3025-1008	Piston	4	4	4	4	4	4
7.	3025-1009	Lock Nut, 1/4-28	2	2	2	2	2	2
8.	3025-1010	Lock Nut, 5/16-24	3	3	3	3	3	3
9.	3025-1012	Wave Spring Washer	4	4	4	4	4	4
10.	3030-1005	Washer	2	2	2	2	2	2
11.	3025-1013	Large O-Ring, EPR	4	4	4	4	4	4
12.	3025-1014	Medium O-Ring, EPR	4	4	4	4	4	4
13.	3025-1015	Small O-Ring, EPR	1	1	1	2	2	2
14.	3030-1006	Hex Head Screw, 5/16-24 x 2.38"	2	2	2			
	3025-1026	Hex Head Screw, 5/16-24 x 2.81"				2	2	2
15.	3025-1016	Hex Head Screw, 1/4-28 x 3.0"	2	2	2			
	3025-1027	Hex Head Screw, 1/4-28 x 3.5"				2	2	2
19.	3005-1015	Drag Ring	4	4	4	4	4	4

ITEM	PART NO.	DESCRIPTION	Quantity					
			3030-0004	3030-0104	3030-0204	3030-0006	3030-0106	3030-0206
20.	3010-1004	Large Retaining Ring	4	4	4	4	4	4
21.	3005-1017	Small Retaining Ring	4	4	4	4	4	4
22.	3025-1020	Large Flat Washer	4	4	4	4	4	4
23.	3025-1019	Small Flat Washer	4	4	4	4	4	4
24.	3030-1007	Hex Head Screw, 5/16-24 x 3.0"	1	1	1			
	3030-1022	Hex Head Screw, 5/16-24 x 3.5"				1	1	1
25.	3030-1008	Spacer, 1.57" Thick	1	1	1			
	3030-1024	Spacer, 2.00" Thick				1	1	1
26.	3030-1023	Housing Spacer				2	2	2
27.	3005-1018	Caplug	1	1	1	1	1	1
28.	0740-1002	Bleeder Valve	4	4	4	4	4	4
29.	3030-1009	Outboard Housing	1	1	1	1	1	1
30.	3030-1010	Inboard Housing	1	1	1	1	1	1
31.	3035-1014	Soft Lining		2			2	
	3035-1016	Hard Lining			2			2

\* Available Only as part of Retractor Body Subassembly 3029-9000

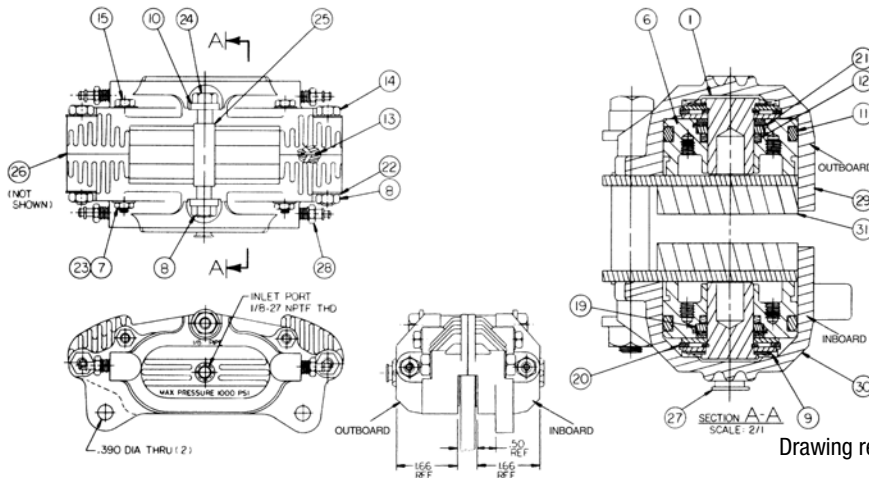

**CAUTION:** Wear adequate eye protection, gloves and clothing during installation. Brake fluid may cause eye irritation. In case of eye contact, flush with water for 20 minutes and get immediate medical attention.

**INSTALLATION**

Tighten mounting bolts to 20 ft-lbs (27.12 N-m). Install the Brake Linings (#31) Hex Head Screw (#24), Spacer (#25), Washer (#10) and Lock Nut (#8). Fill the brake with fresh brake fluid from a sealed container. Connect the brake line to the 1/8-27 NPT fitting. Use TEFLON® tape to seal the pipe threads.

Make certain the Brake Linings are installed BEFORE the brake is pressurized. Then, pressurize the brake and follow the bleeding instructions included in the parts sheet for the Airheart® master cylinder being used.

**OVERHAUL**

A special tool, which must be fabricated by the customer, is required to overhaul the 175 x 2 QCII brake. It should be made from a piece of flatstock steel, 1.50" long x .50" wide x .25" thick, with three holes drilled into it (see Figure 1). The two outer holes are to be .234" diameter and the center hole is to be 1/4-28 UNF tap through. Two #10-24 x 3/4" screws are required for the outer holes and a 1/4-28 x 2" screw with a minimum thread length of 1-1/8" is required for center hole.

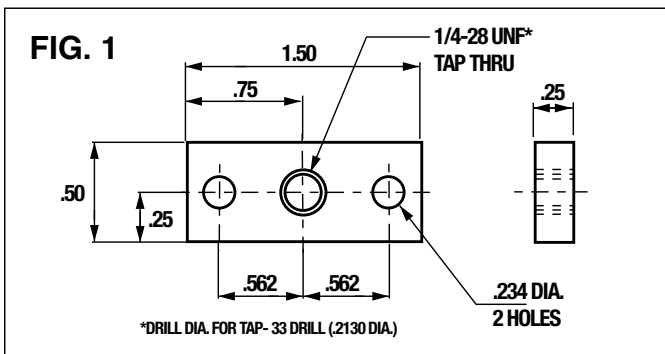

4. Remove the four bolts (#14 & #15) that hold the brake caliper halves together.
  5. Place a small ball bearing in the bottom bore of each Retractor Body (#4) (see Figure 2).
  6. Fasten the special disassembly tool to the piston with the two 10-24 x 3/4" screws. Then, screw the 1/4-28 x 2" screw into the disassembly tool. Turn the screw until the piston is extracted from the caliper.
  7. Remove the Small Retaining Ring (#21) from the Piston (#6).
  8. Remove the Drag Ring (#19).
  9. Remove the Medium O-Ring (#12). Use a needle or O-Ring pick to remove the Large O-Ring (#11) from its groove on the Piston (#6). Be careful to avoid scratching the machined surfaces with sharp point. Remove Large Retaining Ring (#20) from the caliper. Remove the Retractor Body Subassembly (#1), Wave Spring Washer (#9) (and shim, if one is found under the Wave Spring Washer).
- NOTE: DO NOT disassemble the Retractor Body Subassembly.
10. Clean all parts with solvent and either blow them completely dry with compressed air or allow sufficient time for them to completely air dry.
  11. Examine all parts for wear or damage. Mating surfaces must be smooth and free of scoring, nicks, etc. Replace any parts that appear worn or damaged.

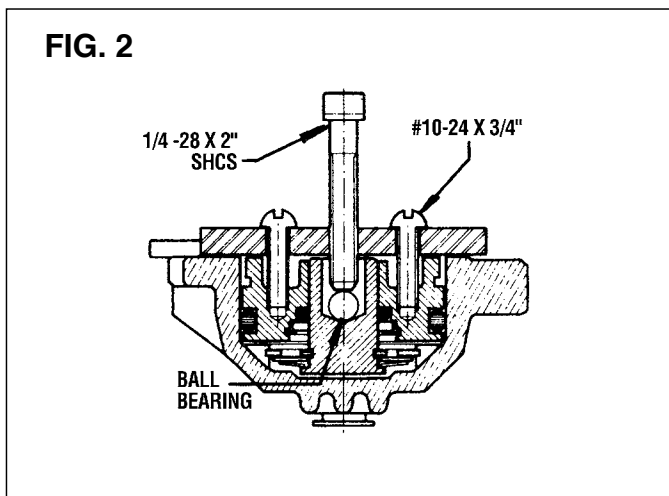

1. Remove the Hex Head Screw (#24), Spacer (#25), Washer (#10) and Lock Nut (#8) and Brake Linings (#31).
2. Disconnect the brake line.
3. Remove the brake from the mounting bracket.

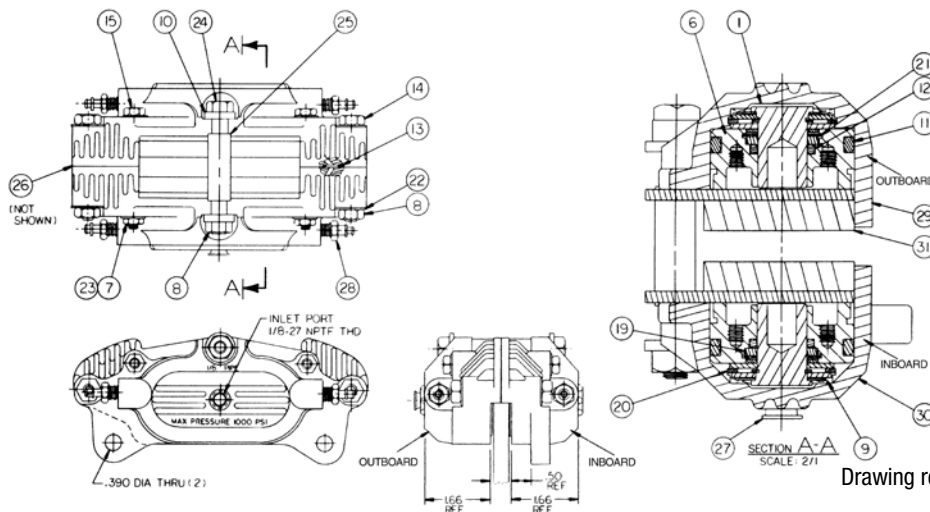

### REASSEMBLY

All parts must be clean and dry. Be sure that all solvent has evaporated before reassembling, as the solvent will damage the O-Rings. Lubricate all of the parts with automotive brake fluid.

The following steps must be performed for each Piston:

1. Install the Medium O-Ring (#12) inside the Piston (#6). Install the Large O-Ring (#11) on the outside of the Piston (#6). Install the Small O-Ring (#13) in its groove between the Inboard (#30) and Outboard (#29) Housing halves.
2. Place a Wave Spring Washer (#9) in the bottom of each piston bore. If a shim was found under the Wave Spring Washer during disassembly, it must be replaced in exactly the same position that it was found.
3. Place the Retractor Body Subassembly (#1) on top of the Wave Spring Washer (#9).
4. Install the Large Retaining Ring (#20) in its recess.
5. Lubricate Piston (#6), Large O-Ring (#11), Housing bore (#29, #30) and Retractor Body (#4) liberally with brake fluid.
6. Place the caliper half in an arbor press with the bore facing up. Place Pilot Pin\* (P/N 3005-1045) in the bore of the Retractor Body Subassembly (#1) and place the Piston (#6) over the bullet nose of the Pilot Pin.
7. Place the Housing (#29 or #30) half on an arbor press. Exercise care as the Piston (#6) is pressed into the bore of the caliper. Make sure the Piston is centered and square as it enters the bore of the caliper. Make certain the O-Ring (#11) on the Piston is not pinched as it enters the bore. Press the Piston down as far as it will go. When this is done, the Pilot Pin will be easy to remove. Use it to repeat this step with the other Piston and Housing half.
8. Assemble the two Housing (#29 or #30) halves together. Make sure to position the Small O-Ring (#13) properly in the fluid transfer passage between the two halves. Note that two Small O-Rings are used in the Spaced version of this brake. Hold the Housing halves (and Housing Spacer (#26), if spaced) firmly together and install the four assembly bolts

FIG. 3

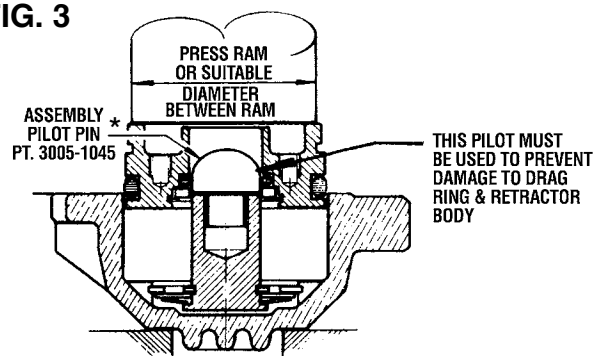

(#14 & #15) and their requisite nuts and washers. Note that the lock nuts are on the Outboard Housing (#29) half, opposite the Inboard (#30) half, with the 1/8-27 NPT inlet port. Use a torque wrench to tighten the bolts.

9. Tighten the 1/4" bolts (#15) first, evenly in steps to 13 ft-lbs (17.63 N-m) MAXIMUM. Next, tighten the 5/16" bolts (#14), evenly in steps to 28 ft-lbs (37.96 N-m) MAXIMUM.
- NOTE: Exceeding the torque figures above will distort the calipers. Insufficient torque will allow flexure and possible drag.
10. Remount the caliper on the vehicle. Replace the Brake Linings (#31) the Hex Head Screw (#18), Spacer (#25), Washer (#10) and Lock Nut (#8).
  11. Fill the brake with fresh brake fluid from an unopened can. Reconnect the pressure line to the inlet port, using TEFLON® tape to seal the threads. DO NOT OVERTIGHTEN. The Piston Retractors will operate when the brake is pressurized.
  12. Bleed the brake accordingly.

\*NOTE: Pilot Pin 3005-1045 must be ordered separately from the Airheart® Brake Company.

Teflon® is a registered trademark of the E.I. DuPont de Nemours Co., www.dupont.com

Airheart®, A and heart symbols are registered trademarks of the Airheart® Brake Division of Tolomatic, Inc.

**Tolomatic**<sup>TM</sup>  
EXCELLENCE IN MOTION

COMPANY WITH  
QUALITY SYSTEM  
CERTIFIED BY DNV GL  
= ISO 9001 =

3800 County Road 116, Hamel, MN 55340 USA  
http://www.Tolomatic.com • Email: Help@Tolomatic.com  
Phone: (763) 478-8000 • Fax: (763) 478-8080 • Toll Free: 1-800-328-2174

Information furnished is believed to be accurate and reliable. However, Tolomatic assumes no responsibility for its use or for any errors that may appear in this document. Tolomatic reserves the right to change the design or operation of the equipment described herein and any associated motion products without notice. Information in this document is subject to change without notice.