

**OBSOLETE: EFFECTIVE JANUARY 1, 2020**

### 150 x 1 Caliper Disc Brake Hydraulic Brake Retractable Piston, Aluminum Housing

#### MODELS AVAILABLE:

**Automotive Brake Fluid**  
3005-0000 No Linings  
3005-0100 Soft Linings  
3005-0200 Hard Linings

**Mineral Base (Red) Fluid**  
3005-0001 No Linings  
3005-0101 Soft Linings  
3005-0201 Hard Linings

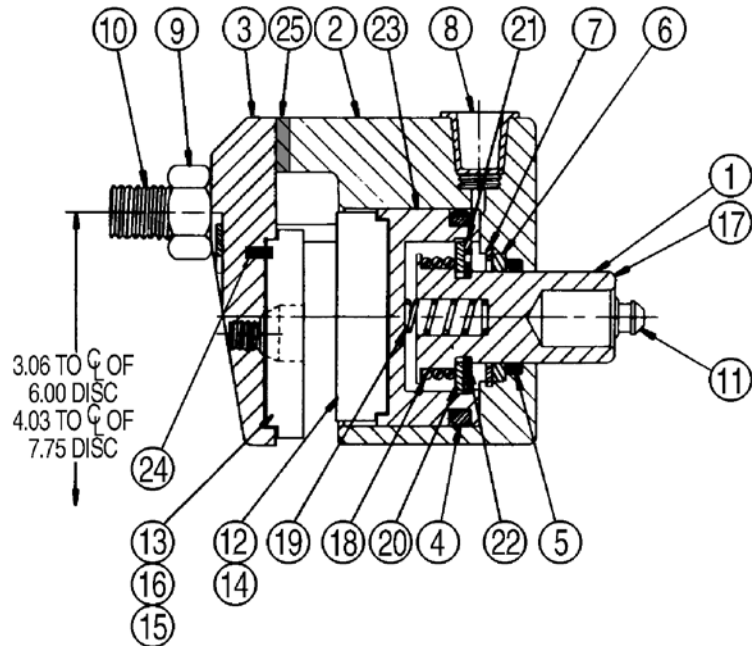
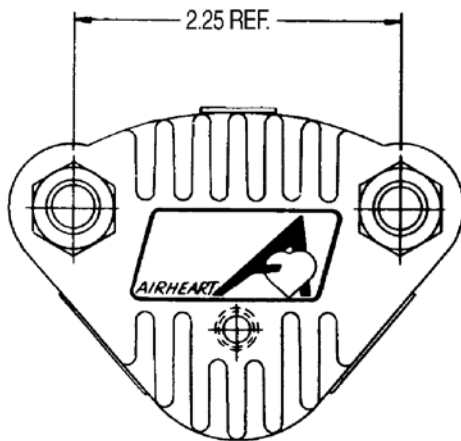

**(1-1-2020) DISCONTINUED PRODUCT STYLE OR SIZE. PARTS SHEET IS FOR REPAIR INSTRUCTIONS ONLY.**

Parts listing is for reference only. All parts listed are limited to stock on hand. Contact Tolomatic regarding availability.

#### Parts Listing

ITEM	PART NO.	DESCRIPTION	Quantity					
			3005-0000	3005-0100	3005-0200	3005-0001	3005-0101	3005-0201
1.	3005-9003	Body / Piston Subassembly	1	1	1	1	1	1
2.	3005-1029	Housing, Automotive Brake Fluid	1	1	1			
	3005-1033	Housing, Mineral Fluid				1	1	1
3.	3005-1030	Hsng, Anvil	1	1	1	1	1	1
*4.	3005-1031	O-Ring Seal, EPR	1	1	1			
	3005-1013	O-Ring Seal, Buna-N				1	1	1
*5.	3025-1014	O-Ring Seal, EPR	1	1	1			
	3005-1012	O-Ring Seal, Buna-N				1	1	1
*6.	3005-1015	Drag Ring	1	1	1	1	1	1
7.	3005-1017	Retaining Ring	1	1	1	1	1	1
8.	3005-1018	Caplug	1	1	1	1	1	1
9.	3000-1008	Lock Nut	2	2	2	2	2	2
10.	3010-1011	Hex Head Bolt, Grade 5, 3.00"	2	2	2	2	2	2
11.	0720-1099	Bleeder Screw, 1/4-28 NPT	2	2	2	2	2	2
12.	3005-1010	Hard Lining, Housing Side			1			1

ITEM	PART NO.	DESCRIPTION	Quantity					
			3005-0000	3005-0100	3005-0200	3005-0001	3005-0101	3005-0201
13.	3005-1035	Hard Lining, Anvil Side			1			1
14.	3005-1024	Soft Lining, Housing Side		1				1
15.	3005-1025	Soft Lining, Anvil Side		1				1
16.	3005-1027	Flat Head Screw, .50"		1	1		1	1
§17.	3005-1007	Piston Body	1	1	1	1	1	1
§18.	3005-1006	Compression Spring	1	1	1	1	1	1
§19.	3005-1003	Compression Spring	1	1	1	1	1	1
§20.	3005-1028	Flat Washer	1	1	1	1	1	1
§21.	3005-1002	Retaining Ring	1	1	1	1	1	1
§22.	3005-1004	Retaining Ring	1	1	1	1	1	1
*§23.	3005-1008	Piston	1	1	1	1	1	1
24.	3005-1052	Dowel Pin	1	1	1	1	1	1
25.	3015-1001	Spacer	1	1	1	1	1	1

\* Overhaul Kit 3005-9004 [Automotive Brake Fluid]  
Overhaul Kit 3005-9005 [Mineral Base (Red) Fluid]

§Available only in Piston/Body Subassembly 3005-9003

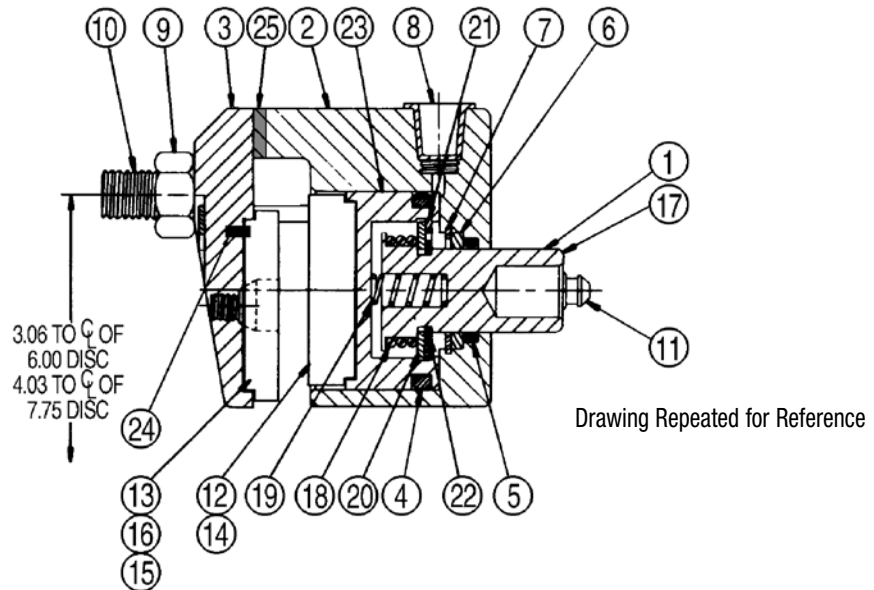
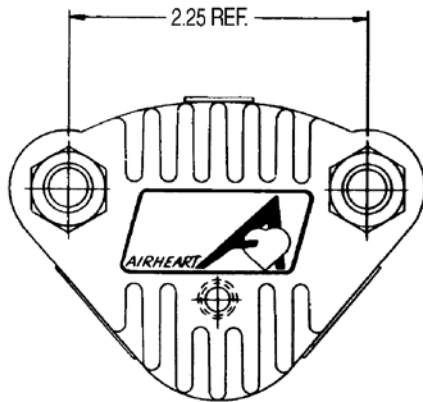

**(1-1-2020) DISCONTINUED PRODUCT STYLE OR SIZE. PARTS SHEET IS FOR REPAIR INSTRUCTIONS ONLY.**

**Parts listing is for reference only. All parts listed are limited to stock on hand. Contact Tolomatic regarding availability.**

#### INSTALLATION

Mount the brake using the two SAE Grade 5 hex bolts. Tighten the nuts to 20 ft-lbs (27.12 N-m). Care must be taken when mounting the brake that the linings faces are parallel to the disc. Use shims, if required. To prevent excessive wear, be sure the disc does not rub against the linings when the piston is retracted.

Disc must be kept free of dirt and grease for maximum life and braking action.

**MAKE CERTAIN THAT THE SEALS IN THE CALIPER ARE COMPATIBLE WITH THE FLUID BEING USED.**

**EPR SEALS – ARE FOR USE WITH AUTOMOTIVE BRAKE FLUID ONLY.**

**BUNA-N SEALS – ARE FOR USE WITH MINERAL BASE (RED) FLUID ONLY.**

Caliper must be mounted at the 3 o'clock or 9 o'clock position for proper bleeding to take place. Bleed through the topmost bleeder only. If the brake is not mounted in this position, it must be removed and held in this position with a 1/8" shim between the linings while bleeding.

#### DISASSEMBLY

1. Disconnect the hydraulic lines and remove the brake from its mounting.
2. Remove the Bleeder Screws (#11).
3. Remove the Anvil Housing (#3) and Spacer (#25).

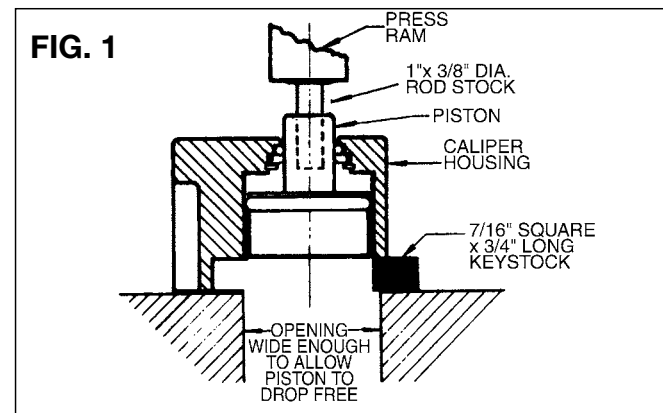

4. Position the brake housing on an arbor press bed with the bore facing down. Support the housing squarely to the axis of the press ram, using a 7/16" square by 3/4" long piece of square key stock. Insert the end of a 1" long piece of 3/8" diameter steel rod stock into the top of the Piston Body Subassembly (#1). Then, press the Piston Subassembly free from the Housing (#2).
5. Remove the Internal Retaining Ring (#7) with a retaining ring pliers.
6. Remove the small O-Ring (#5) from its recess in the Housing (use a needle or O-Ring pick to pry the O-Rings out of the grooves). Then, remove the large O-Ring (#4) from its groove on the Piston Subassembly.
7. Clean the caliper housing with solvent and a stiff brush. Dry the caliper thoroughly with compressed air, or allow sufficient time for the solvent to thoroughly evaporate before reassembling. DO NOT soak the Piston Body Subassembly (#1) in solvent. Instead, wipe it clean with a lint free towel moistened with solvent. DO NOT disassemble the Piston Body Subassembly.

**REASSEMBLY**

1. Lubricate the large O-Ring (#4) and the small O-Ring (#5), the Piston Body Subassembly (#1) and the Housing (#2) bore with the correct operating fluid before reassembly. (Mineral base (Red) fluid for calipers with Buna-N seals, Automotive brake fluid for calipers with EPR seals).
2. Install the large O-Ring (#4) on the Piston Body Subassembly. Then, install the small O-Ring (#5) in the recess of the Housing (#2).
3. Next, prepare to install the Drag Ring (#6). Notice that there is a large chamfer on one edge of the inside diameter of the Drag Ring. The Drag ring must be installed in its recess in the Housing with the chamfered end facing TOWARDS the Piston Body Subassembly.

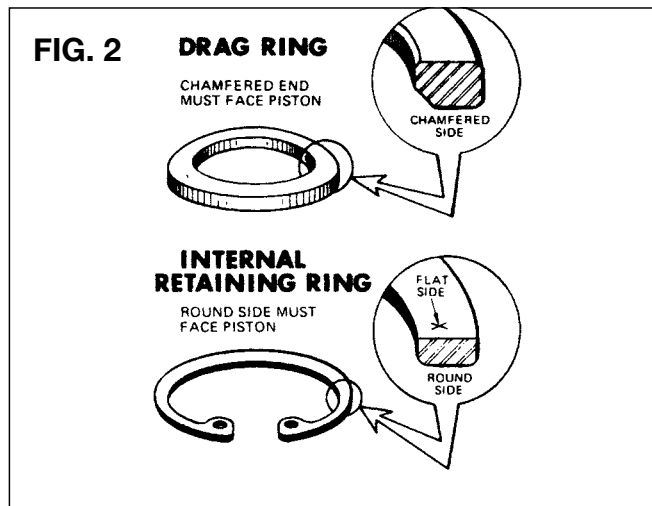

4. Install the Internal Retaining Ring (#7) into its recess in the Housing (#2) with the round side of the ring facing out towards the Piston Subassembly.
5. Set the caliper Housing (#2) down with the open bore facing upward on the bed of an arbor press. Make certain to support the Housing equally, using two pieces of flat keystock 7/16" square by 3/4" long. It is CRITICAL that the piston and the bore be parallel when the assembly is pressed together.
6. Hold the Piston Body upward. Place the Pilot Pin\* (P/N 3005-1045) in the stem of the Piston Body. Lower the Housing (#2) over the Piston (#23) and Pilot Pin. Hold assembly firmly together in hands and turn upside-down after the bullet nose of the Pilot Pin enters the Drag Ring (#6). Place the Housing over opening of the arbor press bed that will clear the passage of the Pilot Pin and the Piston. The two pieces of keystock must be positioned on the press bed to support the circular faced areas but must not interfere with free passage of the Piston and Pilot Pin.

7. The Piston (#23) should enter the bore of the Housing (#2) and the Piston Body (#17) stem should move through the Drag Ring (#6) without any pressure buildup (hydraulic press). Resistance to assembly indicates that the set-up is faulty. Inspect and correct misalignment as indicated. Press the piston in until it bottoms in bore of Housing.
8. Next, place the new friction Lining (#12 or #14) in the Piston Subassembly (#1). Install the other new Lining (#13 or #15) in the Anvil Housing (#3) using the Flat Head Screw (#16). Make sure notch on back of Lining aligns with Dowel Pin (#24).
9. Reinstall the Bleeder Screws (#11). Do not tighten them excessively, as threads may be damaged.

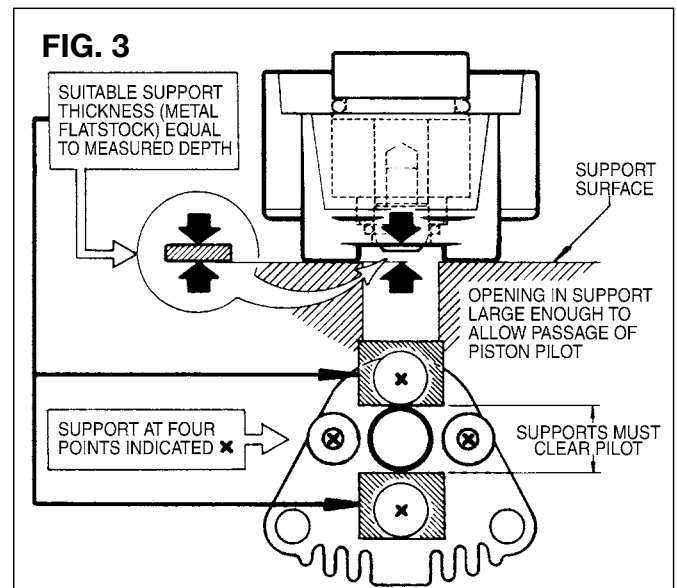

10. Put the Housing (#2), Spacer (#25) and the Anvil Housing (#3) together, using the two Grade 5 bolts (#10) and the Lock Nuts (#9). Then, remount the brake, tightening the bolts to 20 ft-lbs (27.12 N-m).
11. Bleed the brake accordingly.

\*NOTE: Pilot Pin 3005-1045 must be ordered separately from the Airheart® Brake Company.

Weight: 13 oz (0.37kg)  
 Displacement: 0.13 in<sup>3</sup> (2.13cc)  
 Inlet Port: 1/8-27 NPT  
 Total Effective Piston Area: 1.77 in<sup>2</sup> (11.42cm<sup>2</sup>)  
 Maximum Operating Pressure: 1,000 PSI (68.95 bar)

**Overhaul Kits:**

Automotive Brake Fluid: 3005-9004  
 Mineral Base (Red) Fluid: 3005-9005

**Tolomatic**<sup>TM</sup>  
 EXCELLENCE IN MOTION

COMPANY WITH  
 QUALITY SYSTEM  
 CERTIFIED BY DNV GL  
 = ISO 9001 =

3800 County Road 116, Hamel, MN 55340 USA  
<http://www.Tolomatic.com> • Email: [Help@Tolomatic.com](mailto:Help@Tolomatic.com)  
 Phone: (763) 478-8000 • Fax: (763) 478-8080 • Toll Free: 1-800-328-2174

Information furnished is believed to be accurate and reliable. However, Tolomatic assumes no responsibility for its use or for any errors that may appear in this document. Tolomatic reserves the right to change the design or operation of the equipment described herein and any associated motion products without notice. Information in this document is subject to change without notice.