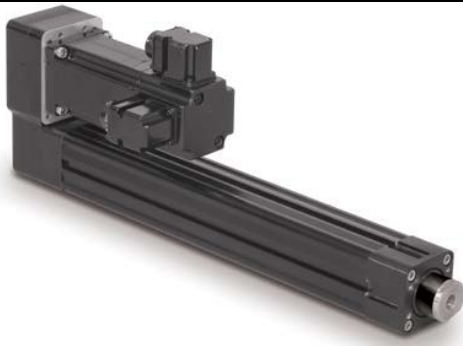
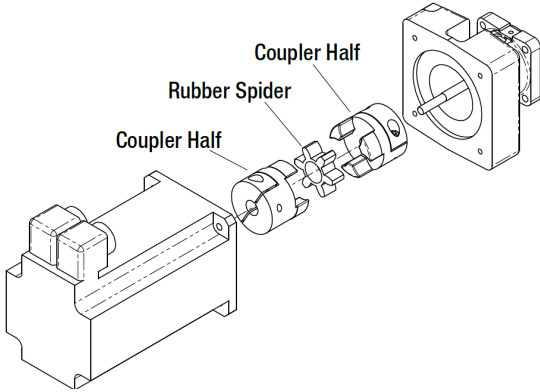
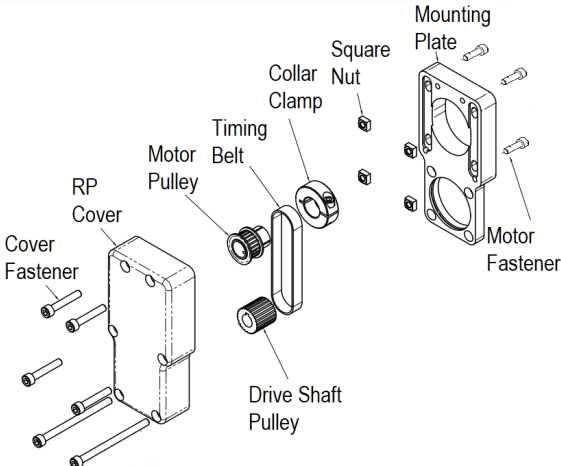

Mounting a Motor to a Tolomatic Actuator

These instructions are a general guide for mounting a 3rd party motor to most Tolomatic actuators. For specific instructions regarding the [RSA](#), [RSH](#), [RSX](#), & [TRS](#) series please see their corresponding operating manuals for motor mounting instructions.

Types of Motor Mounts:

Tolomatic offers two ways of mounting a motor to an actuator: In-line (LMI) and Reverse Parallel (RP). In-Line motor mounts allow the motor to be mounted directly behind the actuator via a spider coupler, which puts it in the same orientation as the actuator. Reverse Parallel mounting allows the motor to be mounted above or to the side of the actuator in the opposite facing direction as the actuator drive shaft. This design utilizes a timing belt to transfer torque from the motor to the actuator in 1:1, 2:1, or 3:1 reduction ratios.

In-line motor mount (LMI)	Reverse Parallel motor mount (RP)
	
	

Motor Mounting Instructions:

In-Line:

1. Insert the motor shaft into the motor coupler located inside the motor spacer on the backside of the actuator.
2. Firmly secure the motor to the spacer with the 4 fasteners provided

3. Remove the cover on the motor spacer to provide access to the fastener on the motor shaft coupler
4. Secure the coupler to the motor shaft by tightening the fastener on the coupler
 - a. See table for torque specifications on these fasteners

[In-line motor mounting video](#)

Reverse Parallel:

1. Remove the cover and/or end caps on the mounting plate, then remove the belt, motor pulley, and fasteners enclosed inside
2. Using the fasteners and square nuts provided loosely attach the motor to the mounting plate
 - a. Do not tighten these fasteners at this time. The motor must be mounted loose enough to slide up and down in the slots for the T-Nuts
3. Slide the timing belt and motor pulley (with collar clamp if included) onto the motor shaft
4. Move the motor pulley to the correct location on the motor shaft so the timing belt is centered on both the actuator and motor pulleys. Tighten the collar clamp fastener and/or set screws on the motor pulley
 - a. Check to make sure the belt is engaging with the pulleys correctly and that it is not rubbing on anything inside the motor mount
5. Hold the motor in place so that the belt does not come off of the pulleys. If needed, tighten one of the motor flange fasteners to hold the motor in place. At this point, no tension should be applied to the belt. This is meant to simply hold the motor and un-tensioned belt in place on the pulleys.
6. Install the cover onto the mounting plate
 - a. NOTE: it is important to install the cover before tensioning the belt, as the cover provides support to the mounting plate and in some units provides additional support for the actuator drive shaft. Failure to install the cover now could lead to damage of the screw or improper tensioning of the belt.
7. After the RP cover is installed, apply weight to the belt by hanging a weight from the motor's flange.

In-line motor mount coupling		
Allen Key Size	Torque spec	
	in-lbs.	N-m
3/32	20	2.3
7/64	25	2.8
9/64	46	5.2
5/32	67	7.6
1/4	135	15.3
5/16	200	22.6
2.5mm	13	1.5
3mm	40	4.5
4mm	67	7.6
5mm	135	15.3

Reverse parallel pulley collar clamp			
Material	Allen Key size	Torque spec	
		in-lbs.	N-m
Steel	7/64	28	3.2
Stainless	7/64	15	1.7
Steel	9/64	49	5.5
Stainless	9/64	28	3.2
Steel	5/32	76	8.6
Stainless	5/32	45	5.1
Steel	3/16	170	19.2
Stainless	3/16	110	12.4
Stainless	2.5mm	10	1.1
Steel	2.5mm	18	2.0
Steel	3mm	40	4.5
Steel	4mm	84	9.5
Steel	5mm	140	15.8
Steel	6mm	345	39.0

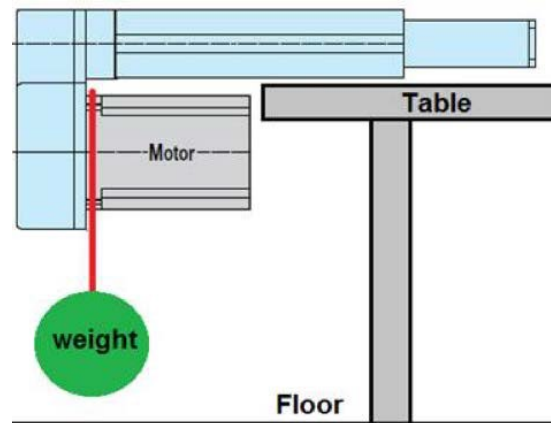

Tolomatic uses the smallest shaft diameter (motor or actuator) as a guideline to determine the amount of total weight that should be applied to the motor, in order to tension the belt. The table below displays these total weight values. The amount of weight being applied to the unit needs to include the weight of the motor.

SMALLEST SHAFT DIAMETER (Motor or Actuator)		TOTAL WEIGHT TO APPLY	
Inches	mm	lbs	kgs
0.18 to 0.259	4.572 to 6.579	13	5.902
0.260 to 0.499	6.604 to 12.675	22	9.988
0.500 to 0.625	12.7 to 15.875	31	14.074
0.625 and larger	15.875 and larger	40	18.160

For example: if the smallest shaft diameter (motor or actuator) is 0.5" (12.7 mm), a total of 31 lbs. (14 kg) of weight needs to be applied. This means if the motor weighs 8 lbs. (3.6 kg), an additional 23 lbs. (10.4 kg) of weight would need to be hung from the motor to create the total 31 lbs. (14 kg) of pull force on the belt (23 lbs. + 8 lbs. = 31 lbs.) (10.4 kg + 3.6 = 14.0 kg). Keep the weight on the motor as close to the mounting surface as possible.

8. After this weight is attached to the motor, loosen the one tightened motor fastener so the motor moves downward from the pull force of the motor’s weight and additional weight that has been applied.
9. Tighten the motor fasteners and remove the weight from the motor.

[Reverse Parallel motor mounting video](#)



MADE IN U.S.A.



Tolomatic™
EXCELLENCE *IN* MOTION

COMPANY WITH
QUALITY SYSTEM
CERTIFIED BY DNV
= ISO 9001 =
Certified site: Hamel, MN

USA - Headquarters
Tolomatic Inc.
 3800 County Road 116
 Hamel, MN 55340, USA
Phone: (763) 478-8000
 Toll-Free: **1-800-328-2174**
 sales@tolomatic.com
www.tolomatic.com

MEXICO
Centro de Servicio
 Parque Tecnológico Innovación
 Int. 23, Lateral Estatal 431,
 Santiago de Querétaro,
 El Marqués, México, C.P. 76246
Phone: +1 (763) 478-8000
 help@tolomatic.com

EUROPE
Tolomatic Europe GmbH
 Elisabethenstr. 20
 65428 Rüsselsheim
 Germany
Phone: +49 6142 17604-0
 help@tolomatic.eu
www.tolomatic.com/de-de

CHINA
**Tolomatic Automation Products
(Suzhou) Co. Ltd.**
 No. 60 Chuangye Street, Building 2
 Huqiu District, SND Suzhou
 Jiangsu 215011 - P.R. China
Phone: +86 (512) 6750-8506
 TolomaticChina@tolomatic.com

All brand and product names are trademarks or registered trademarks of their respective owners. Information in this document is believed accurate at time of printing. However, Tolomatic assumes no responsibility for its use or for any errors that may appear in this document. Tolomatic reserves the right to change the design or operation of the equipment described herein and any associated motion products without notice. Information in this document is subject to change without notice.

Visit www.tolomatic.com for the most up-to-date technical information