

B3S15 Cylinder Wedge-Style Screw-Drive Actuators

1-1/2"/40mm BORE

Replaced 3600-4042

3600-4122_25

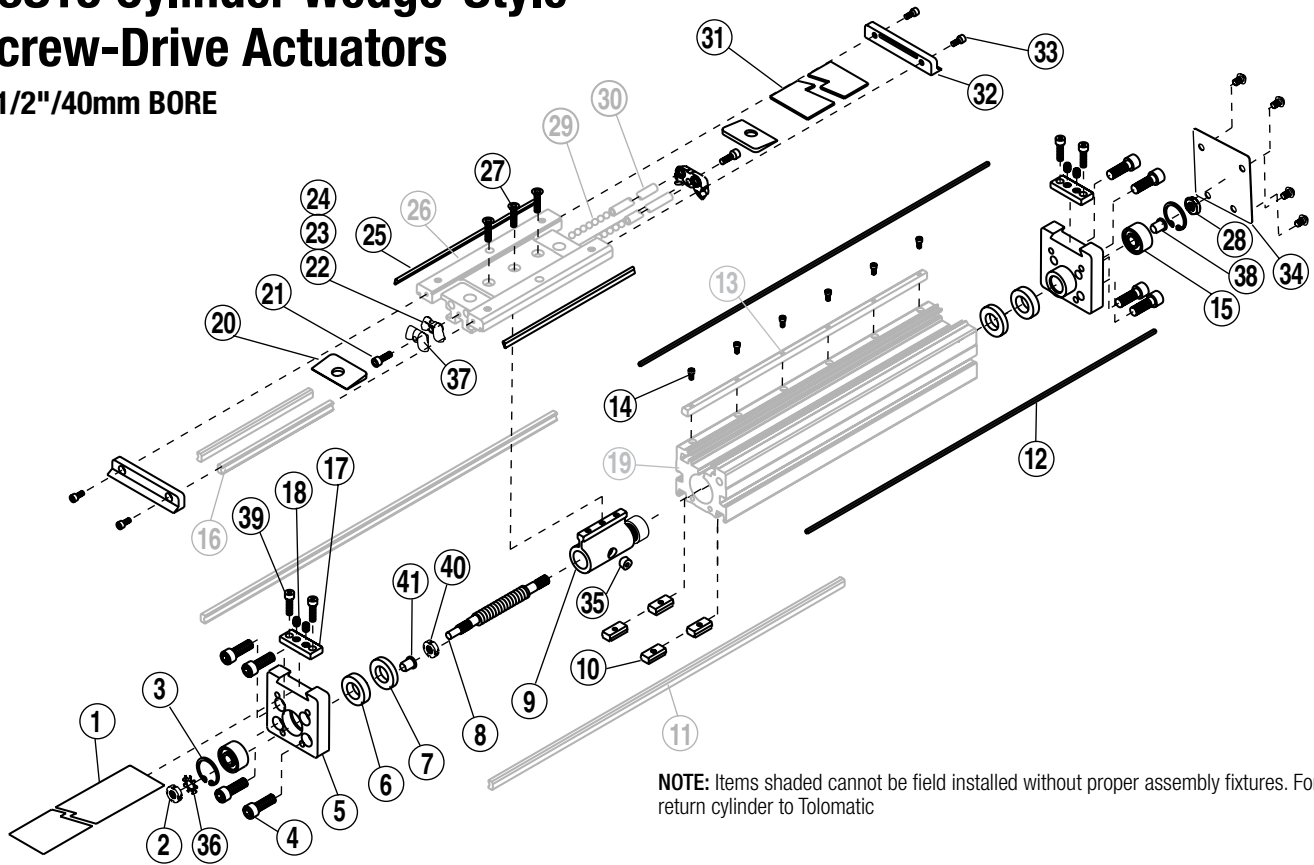

NOTE: Items shaded cannot be field installed without proper assembly fixtures. For repair, return cylinder to Tolomatic

ITEM	PART NO. OR CONFIG. CODE	DESCRIPTION	US CONV (SK)					METRIC (SM)						
			BN02	BNL02	SN02	SNAD02	BN05	BNL05	SN01	SN25*	SN12	BN05	BNL05	
1,21	NDBB3S15_SK_	DUST BAND (US CONV)	A/R	A/R	A/R	A/R	A/R	A/R	A/R					
	NDBB3S15_SM_	DUST BAND (METRIC)							A/R	A/R	A/R	A/R		
2.	1124-1082	SPHERICAL NUT	1	1					1					
	1132-1013	SPHERICAL NUT			1	1	1	1	1	1	1	1		
3.	3415-1307	SNAP RING	2	2	2	2	2	2	2	2	2	2		
4.	1004-1064	SOCKET HEAD CAP SCREW	8	8	8	8	8	8	8					
	4420-1002	SOCKET HEAD CAP SCREW							8	8	8	8		
5.	3415-1300	ACTUATOR HEAD (US CONV)	2	2	2	2	2	2						
	4415-1300	ACTUATOR HEAD (METRIC)							2	2	2	2		
6.	3415-1308	SPACER	1	1									1	1
	3415-1309	SPACER					1	1						
	3415-1310	SPACER			1				1	1	1			
	3415-1312	SPACER	1	1	1	1	1	1	1	1	1	1		
	3415-1315	SPACER				1								
7.	3415-1318	BUMPER	2	2	2	2	2	2	2	2	2	2		

ITEM	PART NO. OR CONFIG. CODE	DESCRIPTION	US CONV (SK)					METRIC (SM)							
			BN02	BNL02	SN02	SNAD02	BN05	BNL05	SN01	SN25*	SN12	BN05	BNL05		
3,8.	RLSB3S15_SK_	LEAD SCREW (US CONV)	A/R	A/R	A/R	A/R	A/R	A/R							
	RLSB3S15_SM_	LEAD SCREW (METRIC)							A/R	A/R	A/R	A/R			
9.	3415-9062	NUT BRACKET ASSY, 1TPI									1				
	3415-9063	NUT BRACKET ASSY, 2TPI													
9.	3415-9064	NUT BRKT ASSY, 2TPI, BALL, AB								1					
	3415-9065	NUT BRACKET ASSY, 5TPI, BALL									1	1			
	3415-9066	NUT BRACKET ASSY, 2TPI, BALL	1												
	3415-9067	NUT BRACKET ASSY, 2TPI, AB					1								
	4415-9027	NUT BRKT ASSY, 12MM LEAD											1		
	4415-9028	NUT BRKT ASSY, 25MM LEAD											1		
	4415-9029	NUT BRACKET ASSY, 5MM LEAD												1	1

¹ Available in Repair Kit No. 3415-9049

A/R = As Required

*SN25 is discontinued

² Replacement Dust Band ordering method: **NDBB3S15** **D** **SK** **□□□□** **DC** **□**

EXAMPLE: **NDBB3S15** **D** **SK** **21.25** **DC** **7**

³ Replacement Lead Screw ordering method: **RLSB3S15** **□□□□** **SK** **□□□□** **LM** **I** **Y** **M** **□□□□** **DC** **□**

EXAMPLE: **RLSB3S15** **BN02** **SK** **21.25** **LM** **I** **Y** **M** **OTBD0** **DC** **□**

Lead Screw Model & Size Nut Style & Size Stroke Length Motor Orientation Motor Code Aux. Carrier

Auxiliary Carrier Option Note: If replacing a Lead Screw (8.), Band Magnet (12.) or Dust Band (1.) on an actuator that has an Auxiliary Carrier, be sure to add "DC ___" to the end of the configuration string when ordering. "DC" indicates the need for additional length and "___" indicates the measurement of space between carriers (in inches [SK] or millimeters [SM]) as indicated earlier in the configuration string.

Dual 180 Carrier Option Note: If equipped with the optional dual 180 carrier, add the letter "D" between the Model & Size and Stroke Length.

Drawing repeated for reference

NOTE: Items shaded cannot be field installed without proper assembly fixtures. For repair, return cylinder to Tolomatic

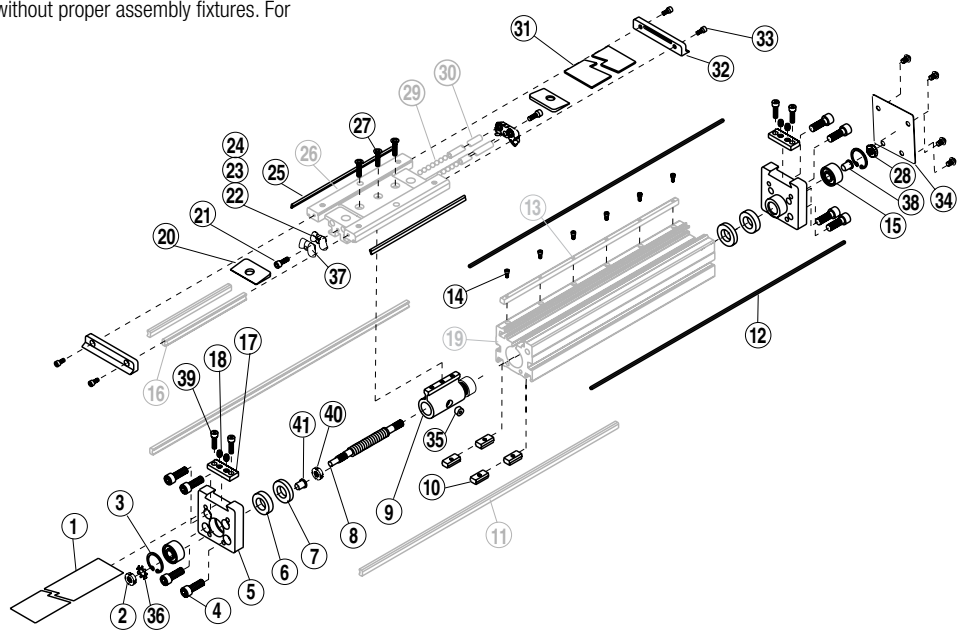

ITEM	PART NO. OR CONFIG. CODE	DESCRIPTION	US CONV (SK)							METRIC (SM)			
			BN02	BNL02	SN02	SNA02	BN05	BNL05	SN01	SM25*	SN12	BN05	BNL05
10.	3415-1013	T-NUT (US CONV)	4	4	4	4	4	4					
	4415-1013	T-NUT (METRIC)							4	4	4	4	
11.	3415-1342	RAIL WAY	2	2	2	2	2	2	2	2	2	2	2
	NMBB3S15_SK_	BAND MAGNET (US CONV)	2	2	2	2	2	2	2	2	2	2	2
512.	NMBB3S15_SM_	BAND MAGNET (METRIC)	A/R	A/R	A/R	A/R	A/R	A/R	A/R	A/R	A/R	A/R	A/R
			A/R	A/R	A/R	A/R	A/R	A/R	A/R	A/R	A/R	A/R	A/R
13.	3415-1141	MACHINED WEDGE	1	1	1	1	1	1	1	1	1	1	1
14.	0605-1048	SOCKET HEAD CAP SCREW	A/R	A/R	A/R	A/R	A/R	A/R	A/R	A/R	A/R	A/R	A/R
15.	3415-1322	CONTACT BEARING	2	2	2	2	2	2	2	2	2	2	2
16.	3415-1024	CARRIER WAY	2	2	2	2	2	2	2	2	2	2	2
17.	3415-1319	UPPER CLAMP	2	2	2	2	2	2	2	2	2	2	2
	4415-1319	UPPER CLAMP							2	2	2	2	2
18.	3415-1455	SET SCREW	4	4	4	4	4	4	4	4	4	4	4
	4410-1017	SET SCREW							4	4	4	4	4
19.	3415-1121	MACHINED TUBE	1	1	1	1	1	1					
	4415-1121	MACHINED TUBE							1	1	1	1	1
20.	3415-1047	UPPER BAND RAMP	2	2	2	2	2	2	2	2	2	2	2
21.	2307-1021	SOCKET HEAD CAP SCREW	2	2	2	2	2	2	2	2	2	2	2
	3212-1025	SOCKET HEAD CAP SCREW							2	2	2	2	2
22.	3415-1014	BALL RETURN	2	2	2	2	2	2	2	2	2	2	2
23.	3415-1015	RIGHT BALL RACE	2	2	2	2	2	2	2	2	2	2	2
24.	3415-1032	LEFT BALL RACE	2	2	2	2	2	2	2	2	2	2	2
25.	3415-1025	WIPER	2	2	2	2	2	2	2	2	2	2	2
26.	3415-2021	MACHINED CARRIER	1	1	1	1	1	1	1	1	1	1	1
	4415-1235	MACHINED CARRIER							1	1	1	1	1

ITEM	PART NO. OR CONFIG. CODE	DESCRIPTION	US CONV (SK)							METRIC (SM)						
			BN02	BNL02	SN02	SNA02	BN05	BNL05	SN01	SM25*	SN12	BN05	BNL05			
27.	3415-1323	FLATHEAD CAP SCREW	3	3	3	3	3	3								
	4415-1012	FLATHEAD CAP SCREW											3	3	3	3
28.	1076-1101	JAM NUT	1	1								1		1	1	1
	1001-1322	JAM NUT			1	1	1	1	1	1	1	1		1	1	1
29.	3415-1009	BALL BEARING	114	114	114	114	114	114	114	114	114	114	114	114	114	114
30.	3415-1019	BALL RETURN TUBE	2	2	2	2	2	2	2	2	2	2	2	2	2	2
31.	3415-2022	CARRIER COVER	1	1	1	1	1	1	1	1	1	1	1	1	1	1
32.	3415-2024	END CAP	2	2	2	2	2	2	2	2	2	2	2	2	2	2
33.	0910-1040	SOCKET HEAD CAP SCREW	4	4	4	4	4	4	4	4	4	4	4	4	4	4
	4415-1001	SOCKET HEAD CAP SCREW											4	4	4	4
34.	3415-9059	HEAD END KIT	1	1	1	1	1	1	1	1	1					
	4415-9055	HEAD END KIT										1	1	1	1	1
35.	3415-1218	MAGNET	2	2	2	2	2	2	2	2	2	2	2	2	2	2
	1124-1092	SPHERICAL WASHER	1	1										1		
36.	3415-2014	SPHERICAL WASHER			1	1	1	1	1	1	1			1	1	1
37.	3415-1109	PLT BALL RETURN	2	2	2	2	2	2	2	2	2	2	2	2	2	2
38.	3415-1320	BEARING SLEEVE	1	1	-	-	-	-	-	-	-	-	1			
39.	0910-1040	SOCKET HEAD CAP SCREW	4	4	4	4	4	4	4	4	4	4				
	4905-1012	SOCKET HEAD CAP SCREW											4	4	4	4
40.	3415-2042	SLEEVE, TAPER	1	1										1		
	3415-2041	SLEEVE, TAPER			1	1	1	1	1	1	1	1			1	1
	3415-2043	SLEEVE, STRAIGHT	1	1										1		

¹Available in Repair Kit No. 3415-9049

⁴Also included in nut bracket assembly (Item 9)

A/R = As Required

⁵Replacement Magnet Band Kit ordering method: **NMB B3S15 D SK [][][][] DC []**
(includes 2 magnet bands)

EXAMPLE: **NMB B3S15 D SK 211-25 DC 7**
Lead Screw Model & Size Stroke Length Aux. Carrier

Auxiliary Carrier Option Note: If replacing a Lead Screw (8.), Band Magnet (12.) or Dust Band (1.) on an actuator that has an Auxiliary Carrier, be sure to add "DC ___" to the end of the configuration string when ordering. "DC" indicates the need for additional length and "___" indicates the measurement of space between carriers (in inches [SK] or millimeters [SM]) as indicated earlier in the configuration string.

Dual 180 Carrier Option Note: If equipped with the optional dual 180 carrier, add the letter "D" between the Model & Size and Stroke Length.

Main Unit Disassembly Instructions

1. Remove Motor Hardware and Dust Band.

Remove any motor, REVERSE PARALLEL, or gearhead hardware from the drive end of actuator. Remove band clamp fasteners(29) and remove band both band clamps(17). Remove the carrier end cap fasteners(33) and end caps(32) from the carrier(26). Slide out the carrier cover(31) and remove the dust band(1).

2. Remove the Non-Drive end Head and Bearing.

Remove the non-drive end cap(34). Remove the non-drive end leadscrew nut(28), while holding the leadscrew from turning at the drive end. Do not allow the actuator carrier to bottom out on end of stroke. Remove head fasteners(4) from the non-drive end of actuator, remove that head(5). It is a slip fit between the bearing and leadscrew journal, but it may be necessary to 'pull' the head off w/ a puller tool as there may be some residual loctite holding the bearing on the leadscrew. Remove the bearing(15) from head by removing the snap ring(3). *Note that on BN02 size, there is a bushing(38) installed in the bearing. Press the bushing out as needed.

3. Remove Leads Screw Assembly.

Remove carrier fasteners(27). Remove drive-end head fasteners(4), and remove leadscrew/head sub-assembly from actuator. Ballnut Style: *Caution is required if removal of the nut or leadscrew is required. Contact the factory for available parts and procedures. Plastic/Bronze Nut Style: The leadscrew may be threaded out of the nut assembly at this point. The nut and nut coupler are pinned and secured w/ Loctite at the factory. If nut is worn, and new nut assembly must be ordered.

4. Remove Lead Screw and Bearing from Head.

Secure the body of the leadscrew in a machinist vice or equivalent smooth jaw vice, then remove the locknut(2). Support the taper bushing (40) if possible and press the leadscrew out of bearing and bushing. The bearing is a press fit on screw journal, and the bushing locked on by means of a mating tapered interface. The snap ring(3) and the bearing(15) can now be removed from the head.

Main Unit Assembly Instructions

1. Sub Assemble Head and Bearing to Lead Screw Assembly.

Install the bearing(15) into the head(5) and install snap ring(3). Position over the leadscrew and nearest the drive end, the longer spacer(6) and the bumper(7). Position taper bushing(40), then bearing/head over leadscrew. It is necessary to press the bearing onto the leadscrew, ensure that the load is only applied to the inner race of the bearing. If not equipped to perform this it will be necessary to purchase this pre-assembled at the factory. Apply loctite 242 to the exposed threads of the leadscrew and install the spherical washer(36) and locknut(2) onto the threads of the leadscrew. Torque the locknut to value listed below, while leadscrew is secured in a machinist vice, or other smooth jaw vice

BN02 Ball Nut	200 in-lbs
All other Nut Types	350 in-lbs

2. Assemble Non-Drive end Head.

Slip bearing into the head, and install the snap ring, flat side of ring toward the bearing. *on BN02, apply retaining compound, Loctite 641 to the journal bushing and ID of the bearing. Install the bushing into the bearing such that the flange portion of the bushing will be toward end of actuator in the assembled state.

3. Assemble Lead Screw Assembly into the Tube.

Grease Leadscrew on both sides of Nut Assembly with a thin film of appropriate grease: either CHRISTOLUBE MCG 303, for solid nut actuators; or MOBIL HP MULTIPURPOSE PREMIUM GREASE for Ball Nut actuators.

Install Leadscrew/Nut assembly in the tube such that as viewed from the motor end, the wedge side of tube is to the left.

4. Install Idle Head and Tighten Heads to Tube.

Attach and tighten the carrier(25) to the nut bracket(9). *On Auxiliary Carrier units, attach the nut bracket to the carrier nearest the motor end of the actuator. Attach the drive end Head to the end of Tube with four SHCS fasteners. Leave loose.

Position bumper and short spacer(if applicable) over the leadscrew and into the tube at the non-motor end. Attach the idle end head to the tube with 4 SHCS sliding the bearing over the journal of the leadscrew. Leave loose.

Move Carrier Assembly to motor-end of tube and tighten head bolts to 105 in-lbs. Support the actuator on the tube such that the head is free to float while tightening the head fasteners.

Move Carrier Assembly to non-motor end of tube and torque to 105 in-lbs. Support the actuator on the tube, such that the head is free to float while tightening the head fasteners.

5. Secure non-motor end of leadscrew.

Apply loctite 242 to the threads on the leadscrew and install the hexnut. Torque nut to 6-8 in-lbs.

6. Lubricate Ballways and install Dust Band.

Lubricate full length of the ballways(11) with Mobil HP grease. Install Dust Band(1) over Carrier(26) centering it along the length of the actuator. Slide the carrier cover(31) into slots of the carrier, and secure end caps(32) to the carrier. With tin snips cut ends as need such that dust band is 1/16" in from ends of heads. Install the band clamps(17) to the heads, and tighten down the set screws(18) locking the band in place.

For special lubrication option grease, email help@tolomatic.com

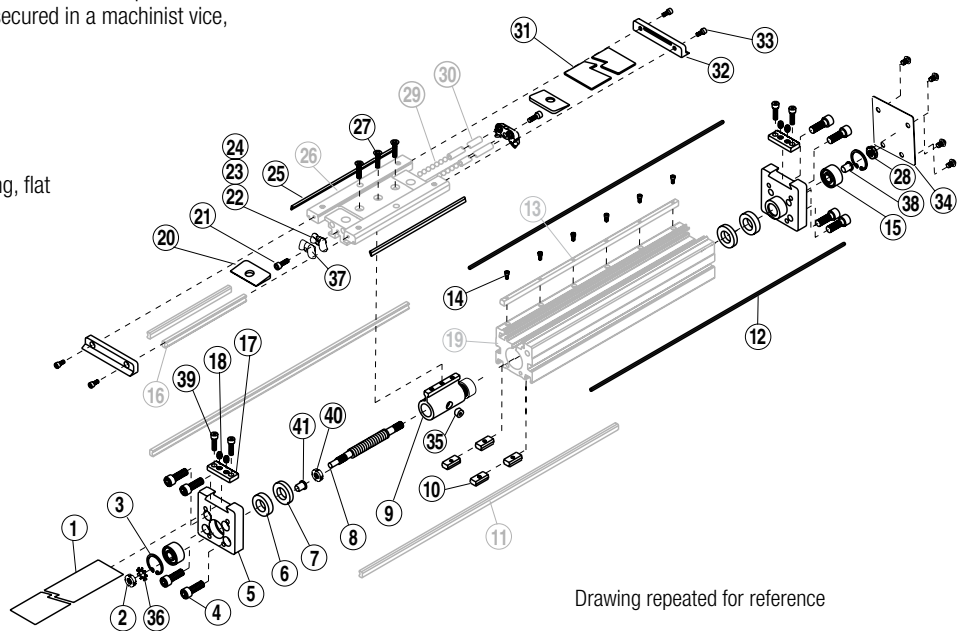

Drawing repeated for reference

Reverse Parallel (RP) Mounting Option

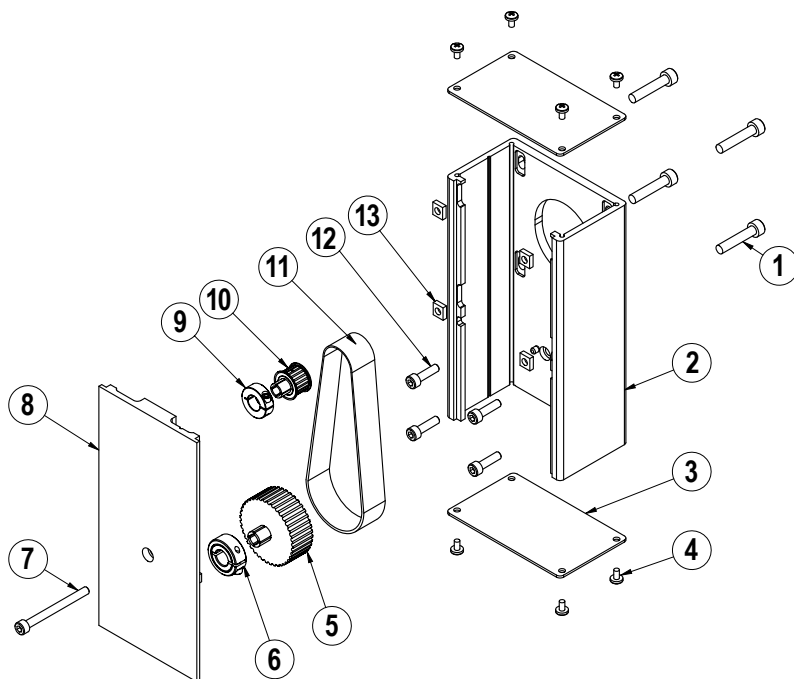

ITEM	PART NO.	DESCRIPTION	QTY.
◊1.	CONFIGURED	MOTOR FASTENER	4
◊2.	CONFIGURED	RP HOUSING	1
◊3.	CONFIGURED	RP HOUSING END CAP	2
◊4.	CONFIGURED	END CAP SCREW	8
◊5.	CONFIGURED	DRIVE SHAFT PULLEY	1
◊6.	CONFIGURED	COLLAR CLAMP, DRIVE SHAFT	1
◊7.	CONFIGURED	RP COVER FASTENER	1
◊8.	CONFIGURED	RP COVER	1
◊9.	CONFIGURED	COLLAR CLAMP, MOTOR	1
◊10.	CONFIGURED	MOTOR PULLEY	1
◊11.	CONFIGURED	BELT	1
◊12.	CONFIGURED	RP PLATE FASTENER	4
◊13.	CONFIGURED	SQUARE NUT	4

◊ Part numbers varies depending on YMH (Your Motor Here).
Contact help@tolomatic.com for replacement part numbers.

Disassembly Instructions

1. Remove End Caps (3), and release the tension on the Belt (11) by breaking loose the motor fasteners (1).
2. Remove the RP Cover (8).
3. The Belt (11) can now be removed along with the Motor.
4. Remove both Pulleys (10) and (5) from their respective shafts.
5. Remove the RP Housing (2) from the actuator head by removing the Fasteners (12).

Assembly Instructions

Note: Apply Loctite #242 to all fasteners upon installation

1. Install RP Housing (2) onto the actuator Head with Fasteners (12).
2. Install the Motor to the RP Housing with Fasteners (1) and Square Nuts (13). Do not tighten the fasteners at this time.
3. Locate the Belt (11) over the Pulleys (10) and (5) and slide both pulleys over their respective shafts. Tighten each pulley to its shaft with the Collar Clamps (9) and (6).
4. Position the Cover (8) in the mating slot of the RP case and install the Fasteners (7) to hold it in place. Take care not to overtighten. If the cover is deflected, it can interfere with the leadscrew.
5. Tension the Belt (11) by pulling the motor away from the drive shaft with the appropriate tension force shown in the chart below. While tensioning, the actuator should be positioned so the weight of the motor does not affect the belt tension. Tighten the Motor Fasteners (1) while the tensioning force is applied to the motor.

SMALLEST SHAFT DIAMETER (Motor or Actuator)		TOTAL WEIGHT TO APPLY	
Inches	mm	lbs	kgs
0.18 to 0.259	4.572 to 6.579	13	5.902
0.260 to 0.499	6.604 to 12.675	22	9.988
0.500 to 0.625	12.7 to 15.875	31	14.074
0.625 and larger	15.875 and larger	40	18.160

Additional tips are found in Tolomatic [Electric Actuator Motor Mounts Technical Note # 3600-4203](#).

6. Verify that there is clearance between the inside of the RP case and each pulley. Verify the pulleys are aligned to each other.
7. Install both End Caps (3) with the Screws (4) to finalize the assembly.

In-Line (LMI) Mounting Options

ITEM	PART NO.	DESCRIPTION	QTY
◊44.	CONFIGURED	MOTOR SPACER	1
◊45.	CONFIGURED	DOWEL PIN	2
◊46.	CONFIGURED	SCREW	4
◊47.	CONFIGURED	SCREW	4
◊48.	CONFIGURED	COVER	1
◊49.	CONFIGURED	CLAMP	1
◊50.	CONFIGURED	SCREW	1
◊51.	CONFIGURED	COUPLER	1

◊ Part number varies depending on YMH (Your Motor Here).
Contact help@tolomatic.com for replacement part number.

A replacement Motor Mount Kit contains all parts listed above.

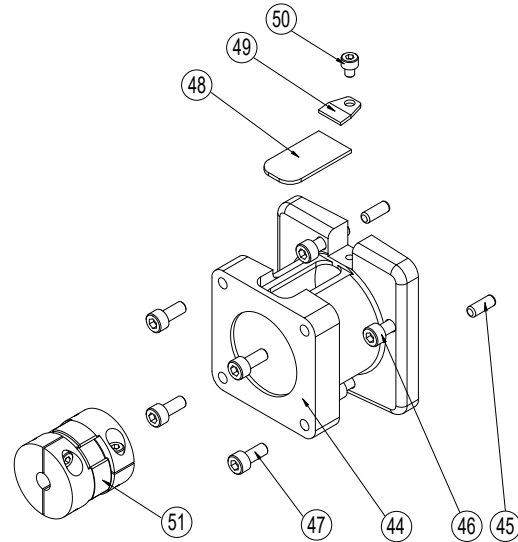

Replacement Motor Mount Kits ordering method: **MMK B3S15** **LMI YM**

EXAMPLE: MMK B3S15 BN025 LMI YM00TBDO

Motor Mount Kit Model & Size Lead Screw Motor Orientation Motor Code

Dual 180° Option

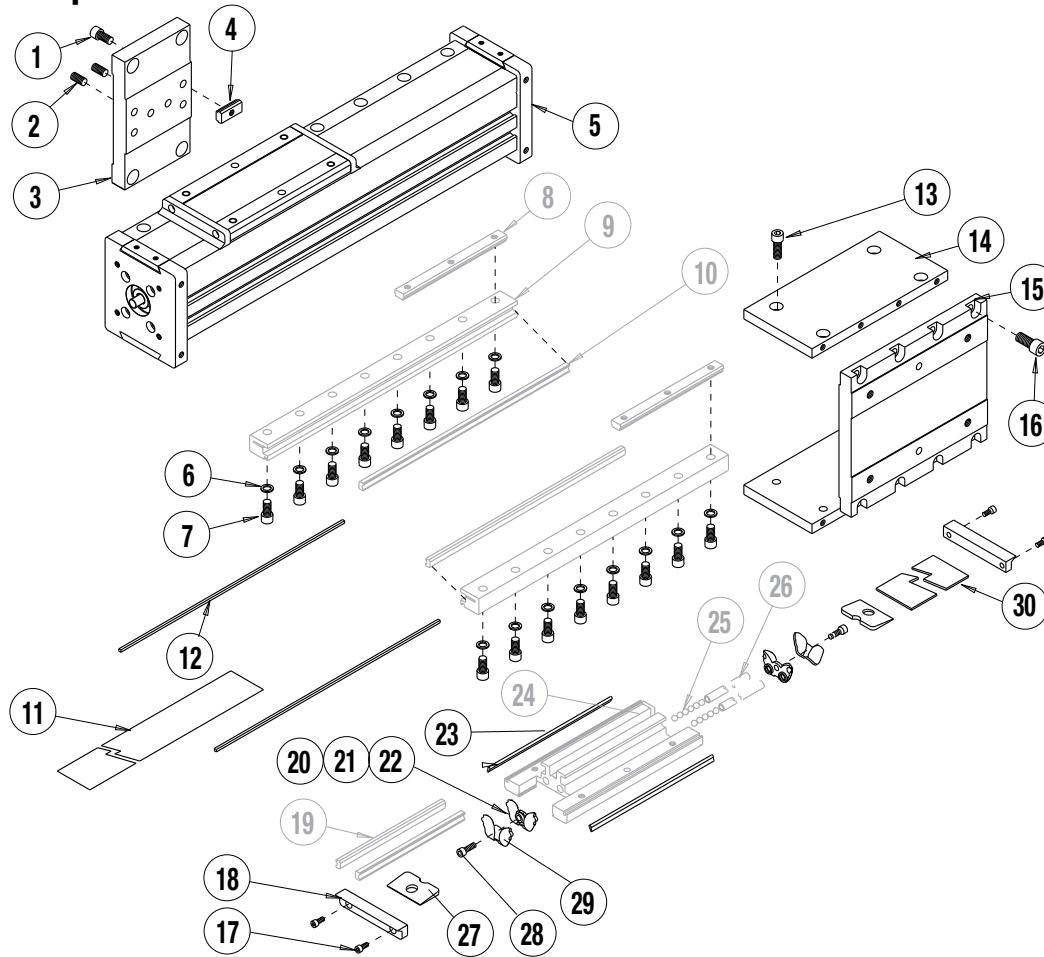

ITEM	US CONV	METRIC	DESCRIPTION	QTY.
² 1.	2317-1014	2517-1108	SOCKET HEAD CAP SCREW	4
² 2.	3415-1219	3415-1219	SET SCREW	2
² 3.	3415-1053	3415-1053	TUBE SUPPORT	1
4.	3415-1013	4415-1013	T-NUT	4
5.	3415-1367	4415-1318	HEAD, DUAL 180° OPTION	2
6.	3415-1059	3415-1059	WASHER	AR
7.	3415-1077	4415-1000	SOCKET HEAD CAP SCREW	AR
8.	3415-1215	4415-1215	RAIL NUT	AR
9.	3415-1342	3415-1342	MACHINED RAIL	2
10.	3415-1341	3415-1341	RAIL WAY	2
^{1,3} 11.	NDBB3S15_SK_	NDBB3S15_SM_	DUST BAND	AR
12.	3415-1340	3415-1340	BAND MAGNET	AR
13.	2317-1014	4415-1000	SOCKET HEAD CAP SCREW	8
14.	3415-1049	4415-1049	PLATE, CONN., DUAL CARRIER	2
15.	3415-1048	4415-1048	PLATE, DUAL CARRIER	1
16.	1209-1019	4420-1002	SOCKET HEAD CAP SCREW	8
17.	0910-1040	4415-1001	SOCKET HEAD CAP SCREW	4
¹ 18.	3415-2024	3415-2024	END CAP	2

ITEM	US CONV	METRIC	DESCRIPTION	QTY.
19.	3415-1024	3415-1024	CARRIER WAY	2
20.	3415-1014	3415-1014	BALL RETURN	2
21.	3415-1015	3415-1015	RIGHT BALL RACE	2
22.	3415-1016	3415-1016	LEFT BALL RACE	2
¹ 23.	3415-1025	3415-1025	WIPER	2
24.	3415-2021	4415-1235	MACHINED CARRIER	1
25.	3415-1009	3415-1009	BALL BEARING	114
26.	3415-1019	3415-1019	BALL RETURN TUBE	2
27.	3415-1047	3415-1047	UPPER BAND RAMP	2
28.	2307-1021	4415-1024	SOCKET HEAD CAP SCREW	2
29.	3415-1109	3415-1109	PLT BALL RETURN	2
¹ 30.	3415-2022	3415-2022	CARRIER COVER	1

¹Available in Repair Kit No. 3415-9049

²Included in Tube Support Kit 3415-9026 or metric 4415-9026

AR = As Required

³Replacement Dust Band ordering method: **NDB B3S15 DSK [] [] [] [] [] [] DC []**
EXAMPLE: NDB B3S15 DSK 21.25 DC 7

Dust Band Model & Size Stroke Length Aux. Carrier

Auxiliary Carrier Option Note: If replacing a Dust Band (11.) on an actuator that has an Auxiliary Carrier, add "DC _ _" between Stroke Length and Motor Code. "DC" indicates the need for additional length and "_ _" indicates the measurement of space between carriers (in inches [SK] or millimeters [SM] as indicated earlier in the configuration string).

Dual 180 Carrier Option Note: If equipped with the optional dual 180 carrier, add the letter "D" between the Model & Size and Stroke Length.

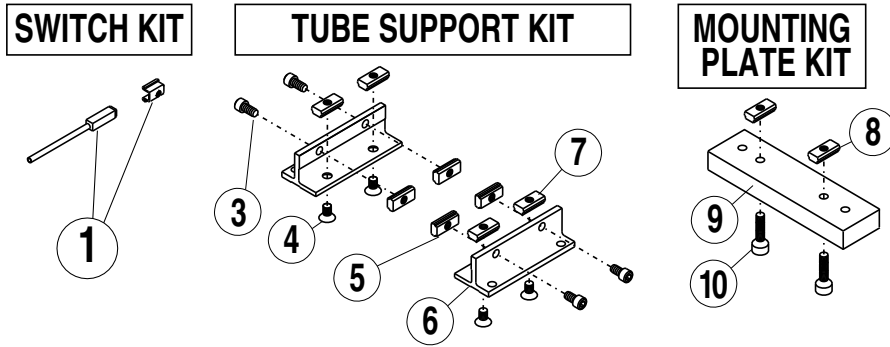

Optional Accessories Parts Listing

ITEM	DESCRIPTION
1.	SWITCH KIT
CONFIG. CODE ORDERING	
CODE	DESCRIPTION
BT	SWITCH KIT, REED, FORM C, 5M
BM	SWITCH KIT REED, FORM C, QUICK DISCONNECT
RT	SWITCH KIT, REED, FORM A, 5M
RM	SWITCH KIT, REED, FORM A, QUICK DISCONNECT
CT	SWITCH KIT, TRIAC, 5M
CM	SWITCH KIT, TRIAC, QUICK DISCONNECT
KT	SWITCH KIT, HALL-EFFECT, SINKING, 5M
KM	SWITCH KIT, HALL-EFFECT, SINKING, QUICK DISCONNECT
TT	SWITCH KIT, HALL-EFFECT, SOURCING, 5M
TM	SWITCH KIT, HALL-EFFECT, SOURCING, QUICK DISCONNECT
NOTE: Switch bracket, set screw, & mating QD cable is included	

ITEM	US CONV (SK)	METRIC (SM)	DESCRIPTION	QTY.
TUBE SUPPORT KIT				
	3415-9006	4415-9006	KIT INCLUDES ALL PARTS LISTED BELOW	
3	0801-1251	4415-1005	SHCS, 10-24 X .44/ M5 X 10	4
4	3415-1046	4415-1014	SFHCS, 10-24 X .38/ M5 X 10	4
5	3415-1013	4415-1013	B3S20 NUT	4
6	3415-1044	3415-1044	TUBE SUPPORT	2
7	3415-1013	4415-1013	B3S20 NUT	4
MOUNTING PLATE KIT				
	3415-9057	4415-9031	KIT INCLUDES ALL PARTS LISTED BELOW	
8	3415-1013	4415-1013	T-NUT	2
9	3415-1332	3415-1332	MOUNTING PLATE 1/2"	1
	3415-1333	3415-1333	MOUNTING PLATE 1"	1
10	0801-1251	8150-1070	SHCS (1/2" PLATE)	2
	1310-1015	2164-1020	SHCS (1" PLATE)	2

Switch Ordering NOTES

To order field retrofit switch and hardware kits for all Tolomatic actuators: SW (Then the model and bore size, and type of switch required)



REPLACEMENT SWITCH MODEL SWITCH CODE

(Hardware and Form A Reed switch with 5 meter lead for 1" size B3S actuator)

Mounting hardware is required if replacing switch for any actuator manufactured before 7/1/97

OPTIONAL ACCESSORY ASSEMBLY INSTRUCTIONS

- TUBE SUPPORTS. Four T-Nuts (5, 7) are required on each side of the Tube, two T-Nuts on bottom of Tube and two in lower slots on tube sides. Tube Supports should be secured at the required distances determined for the application to prevent Tube deflection. Apply Loctite #242 to Screws (3, 4) and secure Tube Supports (6) to Tube aligning holes in T-Nuts with holes in Tube Supports.
- Switches. Secure Switch (1) to magnet side of Tube with Switch Clamp (2) and Set Screw.
- SWITCHES

NOTE: Form A Reed Switches should not be used in TTL logic circuits. A voltage drop caused by the L.E.D. indicator will result. For applications where TTL circuits are used, please contact the factory.

WARNING: An ohmmeter is recommended for testing Reed Switches. NEVER use an incandescent light bulb as a high current rush may damage the switch.

Reed and TRIAC switches are only recommended for signalling position, not directly powering solenoids. For shifting a solenoid, a relay or resistor is recommended between it and the Reed Switch. Switch ratings must not be exceeded at any time.

NOTE: For Hall Effect Switch Magnet, be sure the S pole of the magnet (indicated with black dot) is facing toward the switch (down).

WIRING DIAGRAMS

R T & R M DC REED, FORM A

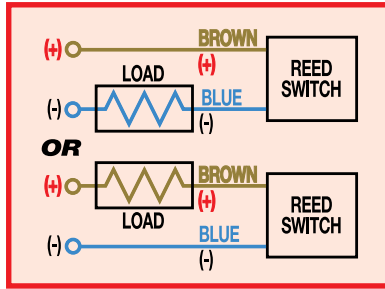

C T & C M AC REED, TRIAC

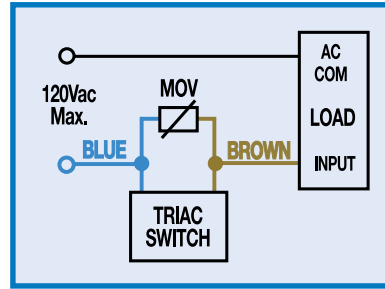

B T & B M DC REED, FORM C

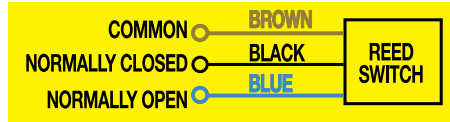

Some actuators may require switch mounting on a specific side of the assembly. Call Tolomatic for details.

T T & T M HALL-EFFECT, SOURCING, PNP

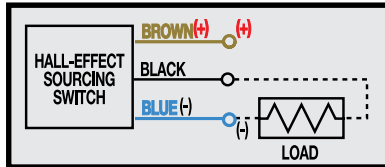

K T & K M HALL-EFFECT, SINKING, NPN

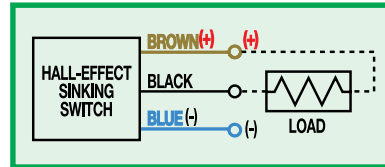

INSTALLATION INFORMATION



⚠
THE NOTCHED FACE OF THE SWITCH INDICATES THE SENSING SURFACE AND MUST FACE TOWARD THE MAGNET.

REPLACEMENT OF QD SWITCHES MANUFACTURED BEFORE JULY 1, 1997:

It will be necessary to replace or rewire the female end coupler.

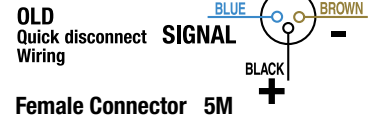

Christo-Lube® is a registered trademark of Lubrication Technology, Inc., www.lubricationtechnology.com
 Loctite® is a registered trademark of the Loctite Corporation, www.loctite.com
 Magnalube®-G is a registered trademark of the Carleton-Stuart Corporation, www.magnalube-g.com



COMPANY WITH
QUALITY SYSTEM
CERTIFIED BY DNV
= ISO 9001 =

3800 County Road 116, Hamel, MN 55340 USA
 http://www.Tolomatic.com • Email: Help@Tolomatic.com
 Phone: (763) 478-8000 • Fax: (763) 478-8080 • Toll Free: 1-800-328-2174

All brand and product names are trademarks or registered trademarks of their respective owners. Information in this document is believed accurate at time of printing. However, Tolomatic assumes no responsibility for its use or for any errors that may appear in this document. Tolomatic reserves the right to change the design or operation of the equipment described herein and any associated motion products without notice. Information in this document is subject to change without notice.