

BCS10 Cylinder-Style Screw-Drive Actuators

1-INCH

Models: SN01 SN02 SNA02
SN05 SN12
BNL08 BN08 BN05

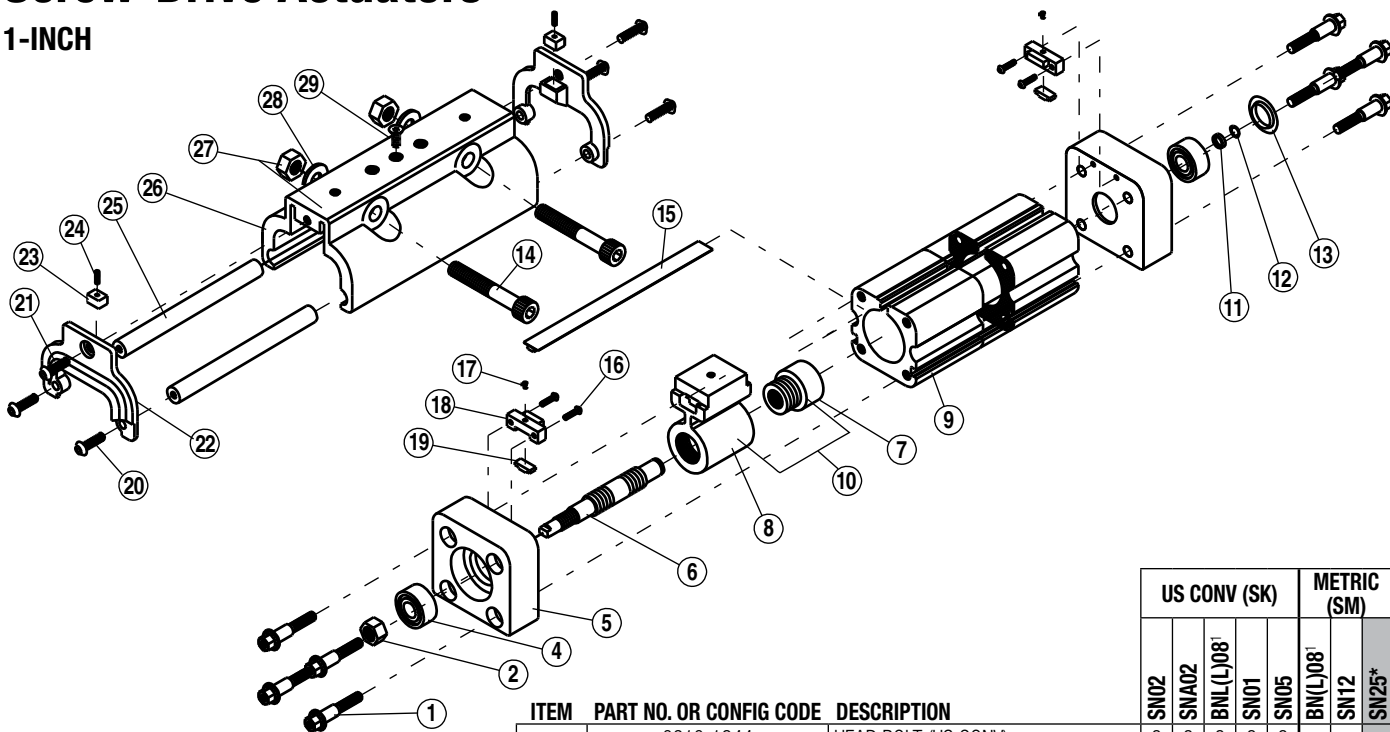

ITEM	PART NO. OR CONFIG CODE	DESCRIPTION	US CONV (SK)			METRIC (SM)			
			SN02	SNA02	BN(L)08 ¹	SN01	SN05	BN(L)08 ¹	SN12
31.	0910-1344	HEAD BOLT (US CONV)	8	8	8	8	8		
	4910-1344	HEAD BOLT (METRIC)						8	8
2.	0910-1482	NUT 5/16-24	1	1	1	1	1		
	4510-1104	NUT M8 X 1.0						1	1
4.	4510-1060	BALL BEARING,RADIAL	2	2	2	2	2	2	2
	0910-1382	HEAD, MACHINED (US CONV)	2	2	2	2	2		
5.	4510-1058	HEAD, MACHINED (METRIC)						2	2
	2.5.6.	RLS BCS10 _ SK _	A/R	A/R	A/R	A/R	A/R		
2.5.6.	RLS BCS10 _ SM _	LEAD SCREW (METRIC)						A/R	A/R
	7.	0910-1430	BALL NUT (US CONV)			1			
4510-1036		BALL NUT (METRIC)						1	
8.	0910-1384	NUT BRACKET (US CONV)			1				
	4510-1167	NUT BRACKET (METRIC)						1	
2.4.9.	RTB BCS10 _ SK _	TUBE, MACHINED (US CONV)	A/R	A/R	A/R	A/R	A/R		
	RTB BCS10 _ SM _	TUBE, MACHINED (METRIC)						A/R	A/R
10.	0510-9051	NUT BRACKET ASSEMBLY	1						
	0510-9052	NUT BRACKET ASSEMBLY		1					
	0510-9053	NUT BRACKET ASSEMBLY				1			
	0510-9054	NUT BRACKET ASSEMBLY					1		
	4510-9044	NUT BRACKET ASSEMBLY						1	
	4510-9045	NUT BRACKET ASSEMBLY							1

¹ Contact help@tolomatic.com when ordering a replacement low backlash (BNL) Ball Screw and Nut

² Specify stroke when ordering

³ When replacing the head bolts in actuators manufactured prior to July 1, 2006, the hole for the head bolt will need to be drilled 0.4" (10mm) deeper to accommodate the longer screw length.

A/R = As Required

*SN25 is Discontinued

Tube Aux. Carrier
⁴ Replacement Tube ordering method: **RTB BCS10** **SK** **DC**
EXAMPLE: RTB BCS10 BN02 SK21.25 DC7

⁵ Replacement Lead Screw ordering method: **RLS BCS10** **SK** **LMI YM** **DC**
EXAMPLE: RLS BCS10 BN02 SK21.25 LMI YM0TBD0 DC7

Lead Screw Nut Style & Size Stroke Length Motor Code Aux. Carrier
Model & Size Motor Orientation

Auxiliary Carrier Option Note: If replacing a Lead Screw (6.), Tube (9.) or Dust Band (15.) on an actuator that has an Auxiliary Carrier, be sure to add "DC _ _" to the end of the configuration string when ordering. "DC" indicates the need for additional length and "_ _" indicates the measurement of space between carriers (in inches [SK] or millimeters [SM] as indicated earlier in the configuration string).

Drawing repeated for reference

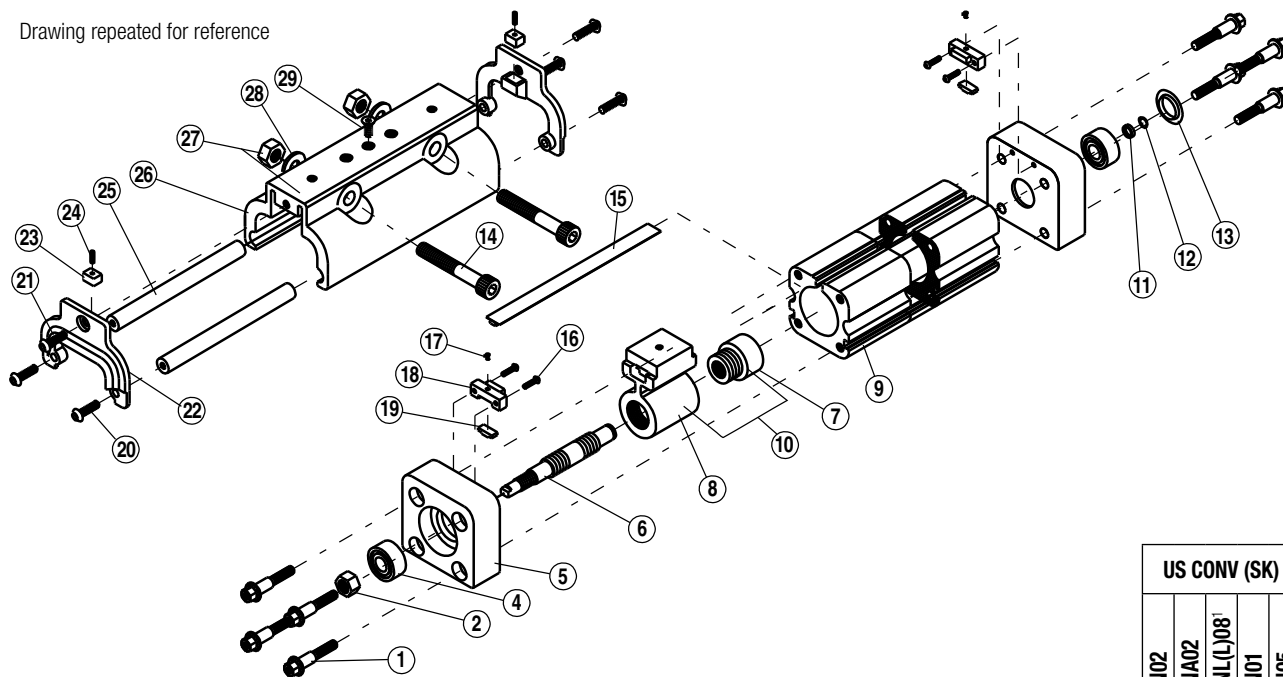

ITEM	PART NO. OR CONFIG CODE	DESCRIPTION	US CONV (SK)					METRIC (SM)		
			SN02	SNA02	BNL(L)08 ¹	SN01	SN05	BN(L)08 ¹	SN12	SN25*
11.	4510-1059	CUP, RETAINING RING	1	1	1	1	1	1	1	1
12.	0510-1019	RING, RETAINING	1	1	1	1	1	1	1	1
13.	0510-1012	PLUG	1	1	1	1	1			
14.	0912-1066	SHCS 1/4-20 X 1.75 LONG	1	1	1	1	1			
	4915-1173	SHCS M6 X 1.0 X 40 LONG						1	1	1
2,6,7,15.	NDB BCS10_SK_	DUST BAND (US CONV)	A/R	A/R	A/R	A/R	A/R			
	NDB BCS10_SM_	DUST BAND (METRIC)						A/R	A/R	A/R
16.	0910-1172	SHCS 6-32 X .50 LONG	4	4	4	4	4			
	4520-1046	SLHCS M4 X 0.7 X 16 LONG						4	4	4
17.	0515-1049	SET SCREW, 8-32 X .25 LONG	2	2	2	2	2			
	0610-1046	SET SCREW, M4 X 0.7 X 6 LONG						2	2	2
18.	0520-9015	BAND CLAMP ASSEMBLY (US CONV)	2	2	2	2	2			
	4515-9023	BAND CLAMP ASSEMBLY (METRIC)						2	2	2
19.	0520-1028	BAND CLAMP SLUG	2	2	2	2	2	2	2	
20.	0910-1172	SHCS 6-32 X .50 LONG	4	4	4	4	4			
	4910-1172	SBHCS M4 X 0.7 X 16 LONG						4	4	4
21.	0910-1290	SBHCS 8-32 X .38 LONG	2	2	2	2	2			
	4910-1003	SLHCS M4 X 0.7 X 8 LONG						2	2	2
6,22.	4510-1002	END CAP,CARRIER	2	2	2	2	2	2	2	
6,23.	4515-1012	BAND INSERT	2	2	2	2	2	2	2	
6,24.	4520-1012	SPRING	2	2	2	2	2	2	2	
6,25.	0910-1170	BEARING, ROD (US CONV)	2	2	2	2	2			
	4910-1170	BEARING, ROD (METRIC)						2	2	2
26.	0510-1025	CARRIER, MACHINED (US CONV)	1	1	1	1	1			
	4510-1049	CARRIER, MACHINED (METRIC)						1	1	1
27.	0912-1016	NUT 1/4-20	2	2	2	2	2			
	4510-1050	NUT M6 X 1.0						2	2	2
28.	1004-1144	WASHER	2	2	2	2	2	2	2	2
	2006-1063	SFHCS 10-24 X .38 LONG	1	1	1	1	1			
29.	4410-1016	SFHCS M5 X 0.8 X 10 LONG						1	1	1

¹ Contact help@tolomatic.com when ordering a replacement low backlash (BNL) Ball Screw and Nut

² Specify stroke when ordering

⁶ Available with Repair Kit #0510-9130

A/R = As Required

*SN25 is Discontinued

⁷ Replacement Dust Band ordering method: **NDB BCS10 SK [] [] [] [] [] DC []**

EXAMPLE: NDB BCS10 SK 21.25 DC7

Dust Band Model & Size Stroke Length Aux. Carrier

Auxiliary Carrier Option Note: If replacing a Lead Screw (6), Tube (9) or Dust Band (15) on an actuator that has an Auxiliary Carrier, be sure to add "DC ___" to the end of the configuration string when ordering. "DC" indicates the need for additional length and "___" indicates the measurement of space between carriers (in inches [SK] or millimeters [SM] as indicated earlier in the configuration string).

Introduction

Begin with a clean work area. Be sure all parts are present and have no visual damage or defects. The following tools are recommended for proper disassembly and assembly (exact wrench sizes will vary depending upon cylinder size):

- Tin Snips
- Allen Wrench Set
- Open-end or Box Wrenches and/or Sockets

Disassembly Instructions

- 1. Remove Carrier:** Remove Bolts (14), Washers (28) and Nuts (27). Remove Carrier (26) from Bracket (8) by removing Screw (29). Remove Spring (24), Band Insert (23), and End Cap (22) by removing Screws (20 and 21) at each end of Carrier. Remove Bearing Rods (25). Remove carrier (26).
- 2. Remove Dust Band:** Loosen Clamp Slug (19) holding Band by loosening Set Screw (17). Remove two Screws (16) securing Band Clamp Assembly (18). Remove Band Clamp Assembly (18) from top of Slug, then remove Clamp Slug from top of Band (next to Head). **IMPORTANT NOTE:** Edges of Dust Band are SHARP — Use caution when handling to avoid injury! Carefully pull the Dust Band (15) from the Tube (9) and through the Nut Bracket Assembly (10)

3. Disassemble Unit.

Remove the four Bolts (1) from both heads (5). Remove the lock nut (2) from the “live side” of the lead screw. Remove the “live side” head w/ bearing (4). Remove the Plug (13) from the “dead side” head. Push ring cup (11) to expose Retaining Ring (12) and remove retaining ring from groove of Lead Screw (6). Remove ring cup and head w/ bearing. Slide lead screw w/ nut bracket (8) and Ball Nut (7) out of Machined Tube (9).

A. Ball Nut Style: DO NOT REMOVE NUT BRACKET w/ BALL NUT FROM LEAD SCREW (balls will fall out).

B. Plastic Nut Style: Remove nut bracket w/ lead screw nut from lead screw.

- 4. Head Sub-Assembly:** If necessary, carefully remove Bearings (4) from both Heads (5).

5. Sub-Assemblies:

Ball Nut Style: Caution is required if removal of nut is necessary. Contact the factory for available parts and procedures.

Plastic Nut Style: Plastic nuts are factory pressed into the Nut Bracket and cannot be removed. If nuts are worn, a new Nut Bracket Assembly must be ordered.

Assembly Instructions

- 1. Area Preparation:** Ensure all parts are present and have no visual damage or defects.
- 2. Prepare Head Sub-Assembly:** Carefully install Bearings (4) in both Heads (5).
- 3. Assemble Unit:**

A. Ball Nut Style: Grease Lead Screw (6) with Mobil HP Multi-purpose grease. Install Lead Screw in machined tube. Place Head (5) on “dead” end of Lead Screw (non-threaded end). Secure with Ring Cup (11) and Snap Ring (12).

NOTE: Make sure the Snap Ring is properly seated in groove on the Lead Screw, then pull Ring Cup over Snap Ring. Install second Head, and Nut (2). Snug up, but do not tighten the four Bolts (1) on each Head. Place an End Plug (13) in the “dead” side Head.

B. Plastic Nut Style: Grease Screw (6) with Christolube® MCG405, assemble Nut Bracket to Screw with the Nut end facing the “live” end (threaded end) of the Screw. Install Screw in machined tube. Place Head on “dead” end of Screw (non-threaded end). Secure with Ring Cup (11) and Snap Ring (12). **NOTE:** Make sure the Snap Ring is properly seated in groove on the lead Screw, then pull Ring Cup over Snap Ring. Install second Head and Nut (2). Snug up, but do not tighten the four Bolts (1) on each Head. Place an End Plug (13) in the “dead” side Head.

- 4. Install Carrier:** Thread one end of Band (15) through slot in Bracket (8) and press down on Band (15) to seat in tube. Place Carrier (26) on Tube and align with Nut Bracket. Install Bearing Rods (25). Secure Spring (24), Band Insert (23), and End Cap (22) in place by tightening Screws (20 and 21) with Loctite 242 to each end of Carrier. Secure Carrier in Bracket by tightening Screws (29) with Loctite 242. Install Bolts (14), Washers (28) and Nuts (27). Snug up the bolts only. **NOTE:** “Snug” means no noticeable end play by hand. If a wrench is applied to either end, both ends will turn.
- 5. Align Heads:** Place Carrier next to each Head then tighten the four Head Bolts (1) to assure proper alignment of Head and Carrier. (When replacing the head bolts in actuators manufactured prior to July 1, 2006, the hole for the head bolt will need to be drilled 0.4” [10mm] deeper to accommodate the longer screw length.)

HEAD TORQUE REQUIREMENTS

Cylinder Size	In-Lbs of Torque
1"	70-80
1-1/2"	100-110
2"	180-195

- 6. Trim and Secure Dust Band:** Locate on one Head a Slug (19) and Band Clamp Assembly (18). (NOTE: Width of Slug should match dust Band width.) Tighten with Screw (16) and Loctite #242. Insert one end of Dust Band (15) under Band Clamp assembly and Slug until it is tight to the Head. Install Set Screw (17) into Band Clamp assembly and tighten against Slug.

With tin snips, cut the end of the Band so it nearly butts to the other Head. Place Clamp Slug (19) on top of Band (next to Head), then place Band Clamp Assembly (18) over Slug. Tighten to Head with two Screws (16) and Loctite #242. Install Set Screws (17).

- 7. Test Procedure:** The torque required to rotate the Lead Screw (6) should not exceed the following limits.

MAXIMUM BREAKAWAY REQUIREMENTS:

Cylinder Size	Torque
1"	25 ounce-inches
1-1/2"	30 ounce-inches
2"	45 ounce-inches

Check and/or readjust unit to conform to specification requirements. Retest.

- 8. Clean unit thoroughly before installing.**

Christo-Lube® is a registered trademark of Lubrication Technology, Inc., www.lubricationtechnology.com
Loctite® is a registered trademark of the Loctite Corporation, www.loctite.com

Reverse Parallel (RP) Mounting Option

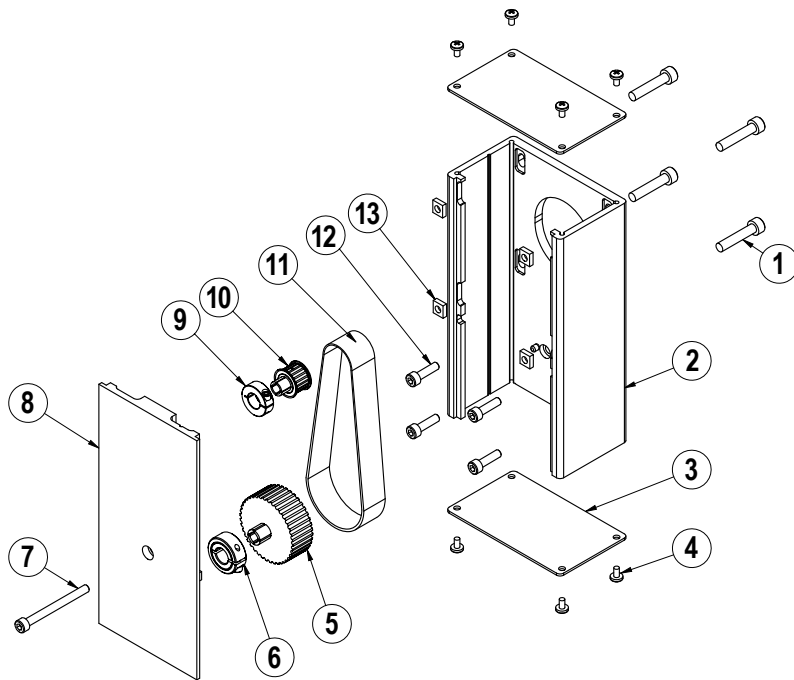

ITEM	PART NO.	DESCRIPTION	QTY.
◊1.	CONFIGURED	MOTOR FASTENER	4
◊2.	CONFIGURED	RP HOUSING	1
◊3.	CONFIGURED	RP HOUSING END CAP	2
◊4.	CONFIGURED	END CAP SCREW	8
◊5.	CONFIGURED	DRIVE SHAFT PULLEY	1
◊6.	CONFIGURED	COLLAR CLAMP, DRIVE SHAFT	1
◊7.	CONFIGURED	RP COVER FASTENER	1
◊8.	CONFIGURED	RP COVER	1
◊9.	CONFIGURED	COLLAR CLAMP, MOTOR	1
◊10.	CONFIGURED	MOTOR PULLEY	1
◊11.	CONFIGURED	BELT	1
◊12.	CONFIGURED	RP PLATE FASTENER	4
◊13.	CONFIGURED	SQUARE NUT	4

◊ Part numbers varies depending on YMH (Your Motor Here).
Contact help@tolomatic.com for replacement part numbers.

Disassembly Instructions

1. Remove End Caps (3), and release the tension on the Belt (11) by breaking loose the motor fasteners (1).
2. Remove the RP Cover (8).
3. The Belt (11) can now be removed along with the Motor.
4. Remove both Pulleys (10) and (5) from their respective shafts.
5. Remove the RP Housing (2) from the actuator head by removing the Fasteners (12).

Assembly Instructions

Note: Apply Loctite #242 to all fasteners upon installation

1. Install RP Housing (2) onto the actuator Head with Fasteners (12).
2. Install the Motor to the RP Housing with Fasteners (1) and Square Nuts (13). Do not tighten the fasteners at this time.
3. Locate the Belt (11) over the Pulleys (10) and (5) and slide both pulleys over their respective shafts. Tighten each pulley to its shaft with the Collar Clamps (9) and (6).
4. Position the Cover (8) in the mating slot of the RP case and install the Fasteners (7) to hold it in place. Take care not to overtighten. If the cover is deflected, it can interfere with the leadscrew.
5. Tension the Belt (11) by pulling the motor away from the drive shaft with the appropriate tension force shown in the chart below. While tensioning, the actuator should be positioned so the weight of the motor does not affect the belt tension. Tighten the Motor Fasteners (1) while the tensioning force is applied to the motor.

SMALLEST SHAFT DIAMETER (Motor or Actuator)		TOTAL WEIGHT TO APPLY	
Inches	mm	lbs	kgs
0.18 to 0.259	4.572 to 6.579	13	5.902
0.260 to 0.499	6.604 to 12.675	22	9.988
0.500 to 0.625	12.7 to 15.875	31	14.074
0.625 and larger	15.875 and larger	40	18.160

Additional tips are found in Tolomatic [Electric Actuator Motor Mounts Technical Note # 3600-4203](#).

6. Verify that there is clearance between the inside of the RP case and each pulley. Verify the pulleys are aligned to each other.
7. Install both End Caps (3) with the Screws (4) to finalize the assembly.

BCS10 Options

(For item 1-29, see drawing on page 1)

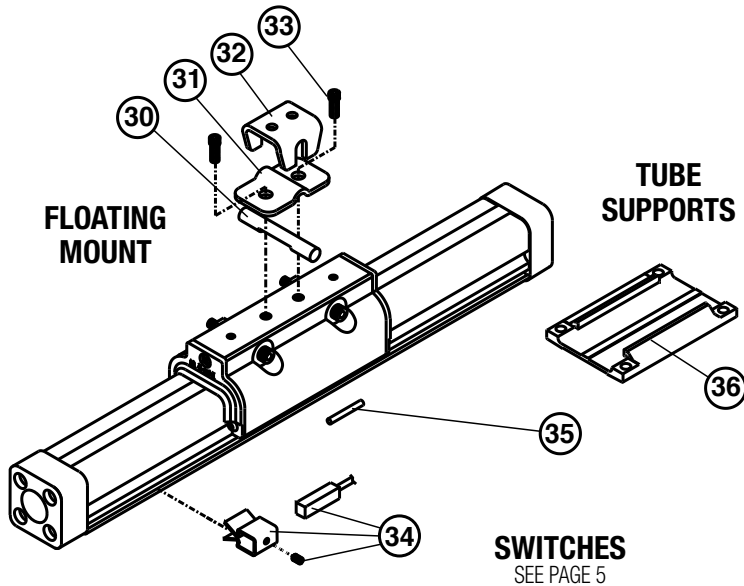

ITEM	PART NO.	DESCRIPTION	QTY
FLOATING MOUNT			
30.	0510-1009	PIN	1
31.	0910-1196	CLAMP	1
32.	0910-1195	BRACKET	1
33.	0910-1199	SCREW	2
SWITCHES			
34.	SEE PAGE 5		
35.	0910-1238	SWITCH MAGNET	1
TUBE SUPPORTS			
36.	4510-1010	BRACKET	1

TUBE SUPPORTS

Follow cylinder assembly instructions through steps 5. Before installing second cylinder Head (#5) in step 6, slide Tube Support (#36) onto cylinder Tube (#9).

FLOATING MOUNT

Completely assemble cylinder. Place Pin (#30) flat side towards Carrier (#26) and between the two center holes. Place Floating Mount Clamp (#31) over Pin (#30) and secure to the Carrier (#26) with Screws (#33) and Loctite® #242. Place Floating Mount Bracket (#32) over Pin (#30) and hold in place with a rubber band.

SWITCHES

On assembled cylinder, Secure Switch to open port side of cylinder with a Hardware Kit (#34) clamp and screw. Cycle the carrier over the Switch by hand to ensure that the carrier does not hit the switch. See page 5 for additional switch information.

In-Line (LMI) Mounting Options

ITEM	PART NO.	DESCRIPTION	QTY
◇44.	CONFIGURED	MOTOR SPACER	1
◇45.	CONFIGURED	DOWEL PIN	2
◇46.	CONFIGURED	SCREW	4
◇47.	CONFIGURED	SCREW	4
◇48.	CONFIGURED	COVER	1
◇49.	CONFIGURED	CLAMP	1
◇50.	CONFIGURED	SCREW	1
◇51.	CONFIGURED	COUPLER	1

◇ Part number varies depending on YMH (Your Motor Here). Contact help@tolomatic.com for replacement part number.

A replacement Motor Mount Kit contains all parts listed above.

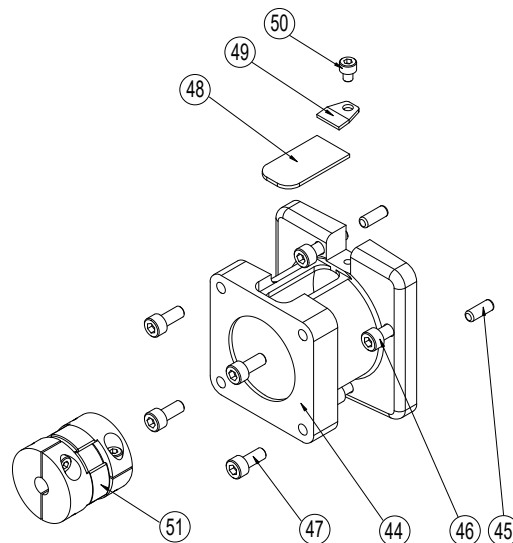

Replacement Motor Mount Kits ordering method: **MMK BCS10** **LMI YM**

EXAMPLE: MMK BCS10 BN08 LMI YM00TBD0

Motor Mount Kit | Model & Size | Lead Screw | Motor Code
Motor Orientation

SWITCH KIT	
CONFIG. CODE ORDERING	
MOUNTING HARDWARE & FE CONN. INCLUDED	
CODE	DESCRIPTION
BT	SWITCH ONLY, REED, FORM C, 5M
BM	SWITCH ONLY, REED, FORM C, MALE CONN.
RT	SWITCH ONLY, REED, FORM A, 5M
RM	SWITCH ONLY, REED, FORM A, MALE CONN.
CT	SWITCH ONLY, TRIAC, 5M
CM	SWITCH ONLY, TRIAC, MALE CONN.
KT	SWITCH ONLY, HALL-EFFECT, SINKING, 5M
KM	SWITCH ONLY, HALL-EFFECT, SINKING, MALE CONN.
TT	SWITCH ONLY, HALL-EFFECT, SOURCING, 5M
TM	SWITCH ONLY, HALL-EFFECT, SOURCING, MALE CONN.

NOTE: When ordered by Config. Code Female connector & all mounting hardware is included

Switch Ordering NOTES:

To order field retrofit switch and hardware kits for all Tolomatic actuators: SW (Then the model and bore size, and type of switch required)

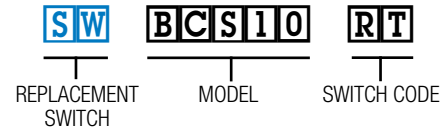

(Hardware and Form A Reed switch with 5 meter lead for 1" size BCS actuator)

Mounting hardware is required if replacing switch for any actuator manufactured before 7/1/97

SWITCHES

NOTE: Form A Reed Switches should not be used in TTL logic circuits. A voltage drop caused by the L.E.D. indicator will result. For applications where TTL circuits are used, please contact the factory.

WARNING: An ohmmeter is recommended for testing Reed Switches. NEVER use an incandescent light bulb as a high current rush may damage the switch.

Reed and TRIAC switches are only recommended for signalling position, not directly powering solenoids. For shifting a solenoid, a relay or resistor is recommended between it and the Reed Switch. Switch ratings must not be exceeded at any time.

NOTE: For Hall Effect Switch Magnet, be sure the S pole of the magnet (indicated with black dot) is facing toward the switch (down).

WIRING DIAGRAMS

RT & RM DC REED, FORM A

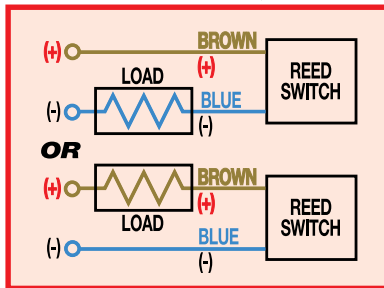

CT & CM AC REED, TRIAC

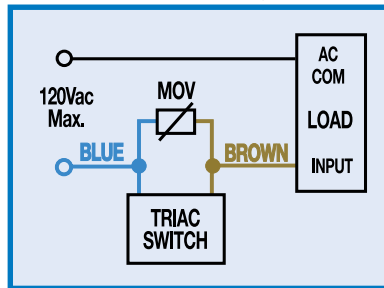

BT & BM DC REED, FORM C

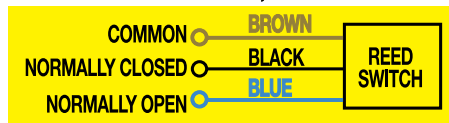

Some actuators may require switch mounting on a specific side of the assembly. Call Tolomatic for details.

TT & TM HALL-EFFECT, SOURCING, PNP

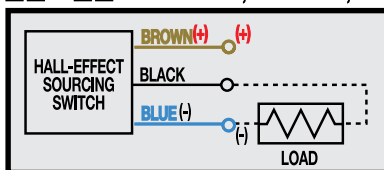

KT & KM HALL-EFFECT, SINKING, NPN

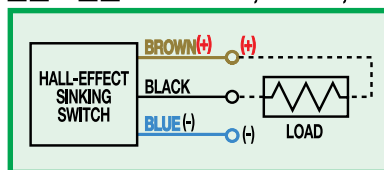

INSTALLATION INFORMATION



THE NOTCHED FACE OF THE SWITCH INDICATES THE SENSING SURFACE AND MUST FACE TOWARD THE MAGNET.

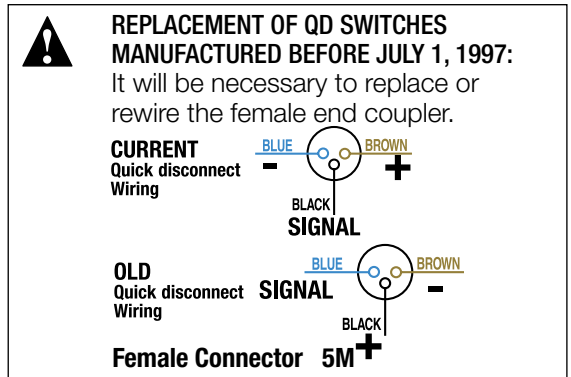

3800 County Road 116, Hamel, MN 55340 USA
 http://www.Tolomatic.com • Email: Help@Tolomatic.com
 Phone: (763) 478-8000 • Fax: (763) 478-8080 • Toll Free: 1-800-328-2174

COMPANY WITH QUALITY SYSTEM CERTIFIED BY DNV = ISO 9001 = Certified Site: Hamel, MN

All brand and product names are trademarks or registered trademarks of their respective owners. Information in this document is believed accurate at time of printing. However, Tolomatic assumes no responsibility for its use or for any errors that may appear in this document. Tolomatic reserves the right to change the design or operation of the equipment described herein and any associated motion products without notice. Information in this document is subject to change without notice.