

PB208, PB210, and PB217 1/2", 5/8" and 1-1/16" Bore

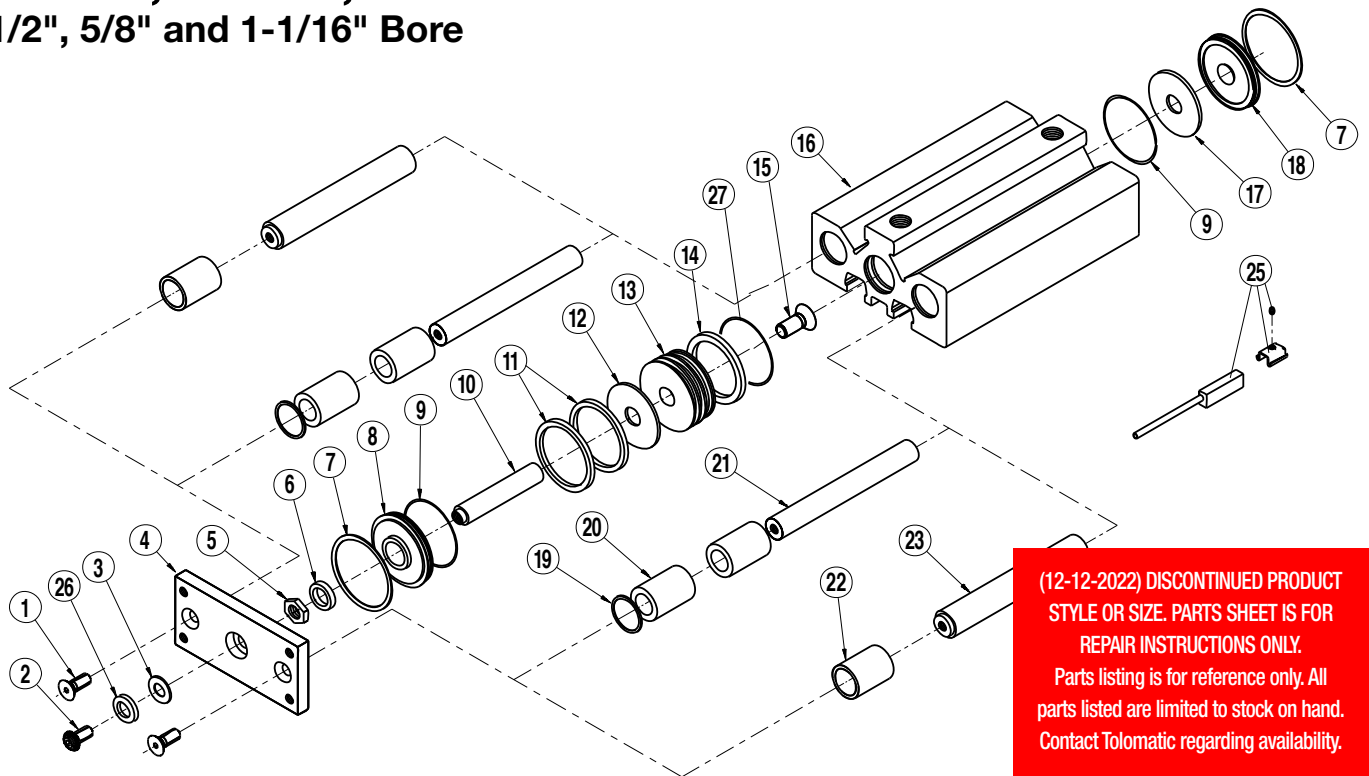

(12-12-2022) DISCONTINUED PRODUCT
STYLE OR SIZE. PARTS SHEET IS FOR
REPAIR INSTRUCTIONS ONLY.
Parts listing is for reference only. All
parts listed are limited to stock on hand.
Contact Tolomatic regarding availability.

List of Parts

ITEM	PART NO. OR CONFIG. CODE	DESCRIPTION	PB208	PB210	PB217
1.	0920-1024	SFHCS		2	
	0925-1031	SFHCS			2
2.	2309-1060	Nut Shoulder		1	
	2517-1126	SHS, BTN			1
3.	2520-1079	Spring, bel.			1
4.	2510-1068	Tooling Plate		1	
	2517-1068	Tooling Plate			1
5.	2307-1007	Nut, Hex, 10-32		1	
6.	2506-1020	Q-Ring, Buna-n		1	
	2520-1080	Q-Ring, Buna-n			1
7.	2510-1029	Ret. Ring		2	
	2517-1029	Ret. Ring			2
8.	2510-1058	Head		1	
	2517-1058	Head			1
9.	0728-1005	O-Ring, Buna-N		2	
	2317-1035	O-Ring, Buna-N			2
10.	2510-1051	Piston Shaft, 1/2" Stroke		1	
	2510-1052	Piston Shaft, 1" Stroke		1	
	2510-1053	Piston Shaft, 1-1/2" Stroke		1	
	2510-1054	Piston Shaft, 2" Stroke		1	
	2510-1055	Piston Shaft, 3" Stroke		1	
	2510-1056	Piston Shaft, 4" Stroke		1	
	2517-1051	Piston Shaft, 1" Stroke			1
	2517-1052	Piston Shaft, 2" Stroke			1

ITEM	PART NO. OR CONFIG. CODE	DESCRIPTION	PB208	PB210	PB217
10.	2517-1053	Piston Shaft, 3" Stroke			1
	2517-1054	Piston Shaft, 4" Stroke			1
	2517-1055	Piston Shaft, 5" Stroke			1
	2517-1056	Piston Shaft, 6" Stroke			1
11.	0915-1009	U-Cup, Buna-N		2	
	2517-1061	U-Cup, Buna-N			2
12.	2510-1022	Bumper		1	
	2520-1102	Bumper			1
13.	2510-1059	Piston		1	
	2517-1059	Piston			1
14.	2402-1013	Mag, Reed/Triac Switches		1	
	2510-1069	Magnet, Hall Effect Switch		1	
	2517-1069	Magnet			1
15.	2510-1038	Nut, Shoulder		1	
	6000-1731	SFHCS			1
16.	2510-1071	Base 1/2" Stroke PB210		1	
	2510-1072	Base 1" Stroke PB210		1	
	2510-1073	Base 1-1/2" Stroke PB210		1	
	2510-1074	Base 2" Stroke PB210		1	
	2510-1075	Base 3" Stroke PB210		1	
	2510-1076	Base 4" Stroke PB210		1	
	2517-1071	Base 1" Stroke PB217			1
	2517-1072	Base 2" Stroke PB217			1
	2517-1073	Base 3" Stroke PB217			1

List of Parts (Continued)

ITEM	PART NO. OR CONFIG. CODE	DESCRIPTION	PB208	PB210	PB217
16.	2517-1074	Base 4" Stroke PB217			1
	2517-1075	Base 5" Stroke PB217			1
	2517-1076	Base 6" Stroke PB217			1
17.	2510-1022	Bumper		1	
	2317-1032	Bumper			1
18.	2510-1057	Cap		1	
	2517-1057	Cap			1
19.	2510-1029	Ret. Ring		2	
	1004-1278	Ret. Ring			2
20.	1001-1192	Linear Bearing		4	
	2312-1011	Linear Bearing			4
21.	2510-1091	Linear Shaft 1/2" Stroke		2	
	2510-1092	Linear Shaft 1" Stroke		2	
	2510-1093	Linear Shaft 1-1/2" Stroke		2	
21.	2510-1094	Linear Shaft 2" Stroke		2	
	2510-1095	Linear Shaft 3" Stroke		2	
	2510-1096	Linear Shaft 4" Stroke		2	
	2517-1091	Linear Shaft 1" Stroke			2
	2517-1092	Linear Shaft 2" Stroke			2
	2517-1093	Linear Shaft 3" Stroke			2
	2517-1094	Linear Shaft 4" Stroke			2
	2517-1095	Linear Shaft 5" Stroke			2
22.	2517-1025	Composite Bearing		4	
	2517-1062	Composite Bearing			4
23.	2510-1081	Slide Shaft 1/2" Stroke		2	
	2510-1082	Slide Shaft 1" Stroke		2	
	2510-1083	Slide Shaft 1-1/2" Stroke		2	
	2510-1084	Slide Shaft 2" Stroke		2	
	2510-1085	Slide Shaft 3" Stroke		2	
	2510-1086	Slide Shaft 4" Stroke		2	
	2517-1081	Slide Shaft 1" Stroke			2
	2517-1082	Slide Shaft 2" Stroke			2
	2517-1083	Slide Shaft 3" Stroke			2
	2517-1084	Slide Shaft 4" Stroke			2
	2517-1085	Slide Shaft 5" Stroke			2
	2517-1086	Slide Shaft 6" Stroke			2
	SWITCHES				
25.	RT	Switch, Reed, Form A, 5M Wire		1	1
	RM	Switch, Reed, Form A, Male Connector		1	1
	BT	Switch, Reed, Form C, 5M Wire		1	1
	BM	Switch, Reed, Form A, Male Connector		1	1
	CT	Switch, TRIAC, 5M Wire		1	1
	CM	Switch, TRIAC, Male Conn.		1	1
	TT	Switch, Source Hall-effect, 5M Wire		1	1
	TM	Switch, Source, Hall-effect, Male Conn.		1	1
	KT	Switch, Sinking Hall-effect, 5M Wire		1	1
	KM	Switch, Sinking, Hall-effect, Male Conn.		1	1
26.	2406-1009	Washer		NA	1
27.	0905-1005	O-Ring (for use w/ magnet for Reed and Triac Switch)		1	NA

ITEM	PART NO. OR CONFIG. CODE	DESCRIPTION	PB208	PB210	PB217
1.	0515-1198	SFHCS	2		
2.	2309-1060	Nut Shoulder	1		
4.	2508-1068	Tooling Plate	1		
5.	2307-1007	Nut, Hex, 10-32	1		
6.	2506-1020	Q-Ring, Buna-n	1		
7.	2508-1078	Ret. Ring	2		
8.	2508-1058	Head	1		
9.	1001-1021	O-Ring, Buna-N	2		
10.	2508-1051	Piston Shaft, 1/2" Stroke	1		
	2508-1052	Piston Shaft, 1" Stroke	1		
	2508-1053	Piston Shaft, 1-1/2" Stroke	1		
10.	2508-1054	Piston Shaft, 2" Stroke	1		
	2508-1055	Piston Shaft, 3" Stroke	1		
	2508-1056	Piston Shaft, 4" Stroke	1		
11.	2508-1108	U-Cup, Buna-N	2		
12.	2508-1102	Bumper	1		
13.	2508-1059	Piston	1		
14.	2508-1069	Magnet	1		
15.	2309-1060	Nut, Shoulder	1		
16.	2508-1071	Base 1/2" Stroke PB208	1		
	2508-1072	Base 1" Stroke PB208	1		
	2508-1073	Base 1-1/2" Stroke PB208	1		
	2508-1074	Base 2" Stroke PB208	1		
	2508-1075	Base 3" Stroke PB208	1		
	2508-1076	Base 4" Stroke PB208	1		
17.	2508-1102	Bumper	1		
18.	2503-1057	Cap	1		
19.	2506-1029	Ret. Ring	2		
20.	2508-1109	Linear Bearing	2		
21.	2508-1091	Linear Shaft 1/2" Stroke	2		
	2508-1092	Linear Shaft 1" Stroke	2		
	2508-1093	Linear Shaft 1-1/2" Stroke	2		
	2508-1094	Linear Shaft 2" Stroke	2		
	2508-1095	Linear Shaft 3" Stroke	2		
	2508-1096	Linear Shaft 4" Stroke	2		
22.	2508-1080	Composite Bearing	2		
23.	2508-1081	Slide Shaft 1/2" Stroke	2		
	2508-1082	Slide Shaft 1" Stroke	2		
	2508-1083	Slide Shaft 1-1/2" Stroke	2		
	2508-1084	Slide Shaft 2" Stroke	2		
	2508-1085	Slide Shaft 3" Stroke	2		
	2508-1086	Slide Shaft 4" Stroke	2		
SWITCHES					
25.	RT	Switch, Reed, Form A, 5M Wire	1		
	RM	Switch, Reed, Form A, Male Conn.	1		
	BT	Switch, Reed, Form C, 5M Wire	1		
	BM	Switch, Reed, Form A, Male Conn.	1		
	CT	Switch, TRIAC, 5M Wire	1		
	CM	Switch, TRIAC, Male Conn.	1		
	TT	Switch, Source Hall-effect, 5M Wire	1		
	TM	Switch, Source, Hall-effect, Male Conn.	1		
	KT	Switch, Sinking Hall-effect, 5M Wire	1		
	KM	Switch, Sinking, Hall-effect, Male Connector	1		
26.	2406-1009	Washer	NA		
27.	0905-1005	O-Ring (for use w/ magnet for Reed and Triac Switch)	NA		

Disassembly and Assembly Instructions

POWER-BLOCK2 DISASSEMBLY

- To remove the Tooling Plate (#4) and Shafts (#21 or #23) first remove the Button Head Screw (#2). Note, for later reassembly, that the cupped surface of the Belleville Spring (#3) faces toward the Tooling Plate. Pull on the Tooling Plate (#5). The Tooling Plate and Shafts (#21 or #23) will slide out of the assembly.
- Push Head (#8) into bore to expose a gap between Head and Retaining Ring (#7). To remove the Head use a screwdriver to remove the Retaining Ring. The Head is now free to be removed.
- Remove the Piston/Piston Shaft Assembly from the Base (#16). Loosen Socket Flat Head Screw (#15) to remove the Piston Shaft (#10) from the Piston (#13). When removing the two U-Cups (#11) from the Piston note that the flare of the U-Cups face away from each other. In looking at the piston from the side view the two U-Cups form a "V" shape.
- Push Cap (#18) into bore to expose a gap between Cap and Retaining Ring (#7). Using a screwdriver remove the Retaining Ring from the Cap side of the Base (#16). Remove the Cap from the Base.
- To remove the Linear Bearings (#20) or the Composite Bearings (#22) use a screwdriver to remove the two Retaining Rings (#19) from the shaft bores of the Base (#16). The Bearings (#20 or #22) may now be pushed out, with a screwdriver.

POWER-BLOCK2 ASSEMBLY PROCEDURE

Clean work bench and area, check that all parts are there and without any visual damage or defects.

1. Base Assembly

PB208 and PB210 Models

(Composite and Linear Bearings) By hand press new Composite Bearing (#22) or Linear Bearing (#20), outside chamfered side down, into each of the two bearing bores in the Base (#16). Press an additional Bearing (#22) or (#20) outside chamfered side down, into the same two bearing holes in the Base. Bearing must be recessed to allow for retaining ring. Using a ring spreader insert two Retaining Rings (#19) to retain the Bearings.

PB217 Models

(Composite Bearings) Press new Composite Bearing (#22), outside chamfered side down, into each of the two bearing bores in the Base (#16). Press an additional Bearing (#22) outside chamfered side down, into the same two bearing holes in the Base with an arbor press until the bearing is flush with the front surface of the base.

(Linear Bearings) Place new Linear Bearing (#20) into each of the bearing bore holes in the Base (#16). Place second Linear Bearing into each of the bearing bore holes. Install the Retaining Rings (#19) into the grooves in the bores to hold the Bearings in place.

2. Cap Assembly

- Thoroughly lubricate the center bore of the base.
- Apply Loctite #495 to the recess in the Cap (#18) then press in the Bumper (#17) with the grooves in the Bumper facing away from the Cap.
- Install an O-Ring (#9) into the cap. Place a thin coat of Magnalube®-G over the O-Ring. Push the Cap (#18); Bumper side in, into the counterbore on the back side of the Base (#16). (Note: the mounting holes on the base are closest to the front side.)
- Install a Retaining Ring (#7) in the groove behind the Cap (#18).

3. Piston Assembly

PB208, PB210 and PB217 Models

- Install the two U-Cups (#11) into the two grooves on the Piston (#13) with the flares of each U-Cup facing away from each other.
- Apply Loctite #271 to the Piston Shaft (#10) threads and screw Shaft into the end of the Piston (#13) which is counterbored. Hand tighten.
- Apply Loctite #271 to the Socket Head Flat Screw (#15) and attach the Magnet to the Piston (#13) with secured Shaft and tighten nut with the appropriate hand wrench. DO NOT OVERTIGHTEN.

- Place a Bumper (#12) over the Piston Shaft (#10) so that the flat side is against the Piston.
- Place a thin coat of Magnalube®-G on the Piston Shaft (#10) and U-Cups (#11).
- Push the Piston Rod assembly, Piston first, into the front side of the center bore on the Base (#16).

PB220 Models

- Apply Loctite #271 to the Socket Flat Head Screw (#15) and attach the Piston (#13) to the flat end of the Piston Shaft (#10).
- Install the two U-Cups (#11) into the two remaining grooves in the Piston (#13) note that the flare of the U-Cups must face away from each other. In looking at the piston from the side view the two U-Cups form a "V" shape.
- Place a Bumper (#12) over the Piston Shaft (#10) so that the flat side is against the Piston (#13)
- Place a thin coat of Magnalube®-G on the Piston Shaft (#10) and the U-Cups (#11).
- Push the Piston/Piston Shaft Assembly, Piston first, into the front side of the center bore of the Base (#16).

4. Head Assembly

- Lubricate the Quad Ring (#6) with Magnalube®-G and insert into the center of the Head (#8).
- Press the Retaining Ring (#7) flush into the center of the Head (#8).
- Install an O-Ring (#9) onto the Head. Place a thin coat of Magnalube®-G over the O-Ring and Quad Ring (#6). Guide the Head over the Piston Shaft (#10) and push the Head (#8), flat surface in, into the counterbore on the front side of the Base (#16).
- Install a Retaining Ring in the groove in the counterbore in front of the Head (#8).

5. Tooling Plate and Bearing Rod Installation

PB208 and PB210 Models

- Clean the Hex Nut (#5) and Socket Head Flat Screw (#15) and apply Loctite #242 to the Piston Shaft (#10) threads
- Attach the Tooling Plate (#4) to the Piston Shaft (#10) with the Hex Nut and Shoulder Nut. The Shoulder Nut goes on the outside of the Tooling Plate. Adjust the position so that the end of the piston shaft is flush with the outer surface of the Hex Nut. Tighten with the appropriate wrenches.

PB217 Models

- On units with Composite Bearings only, apply a small amount of Magnalube®-G into the bearings on the base. No additional lubricant is needed with the Linear Bearings. Insert the Guide Shafts (#21 or #23) with the drilled and tapped holes towards the Tooling Plate (#4) through the bearings. Apply Loctite #271 to the threads of the two SHCS (#1) and attach the Tooling Plate to the Guide Shafts (#21 or #23).
- Apply Loctite #242 to the threads of the Button Head Screw (#2). Attach the Tooling Plate (#4) to the Piston Shaft (#10) with the Button Head Screw and Belleville Spring (#3). Note that the cupped surface of the Belleville Spring (#3) faces toward the Tooling Plate. Tighten all screws.
- Cycle the assembly back and forth by hand to seat the Bumpers, End Cap and Head.

(12-12-2022) DISCONTINUED PRODUCT
STYLE OR SIZE. PARTS SHEET IS FOR
REPAIR INSTRUCTIONS ONLY.
Parts listing is for reference only. All
parts listed are limited to stock on hand.
Contact Tolomatic regarding availability.

6. Switch Option

Clamp for switch will fit in either of the two grooves on the top (porting) side of the Base (#16). Secure Switch to the Base with Clamp and Set Screw. Note the scored surface of the Switch housing should face the base of the Power-Block2.

NOTE: Form A Reed Switches should not be used in TTL logic circuits. A voltage drop caused by the L.E.D. indicator will result. For applications where TTL circuits are used, please contact the factory.

WARNING: An ohmmeter is recommended for testing Reed Switches. NEVER use an incandescent light bulb as a high current rush may damage the switch.

Reed and TRIAC switches are only recommended for signalling position, not directly powering solenoids. For shifting a solenoid, a relay or resistor is recommended between it and the Reed Switch. Switch ratings must not be exceeded at any time.

NOTE: For Hall Effect Switch Magnet, be sure the S pole of the magnet (indicated with black dot) is facing toward the switch (down).
TO ORDER RETROFIT KITS: SW (then the model number and base size, and code for type of switch needed): **EXAMPLE: SWPB210RM**

All Switch Kits come with 1 switch and mounting hardware.

Female Connector 5M

(12-12-2022) DISCONTINUED PRODUCT STYLE OR SIZE. PARTS SHEET IS FOR REPAIR INSTRUCTIONS ONLY. Parts listing is for reference only. All parts listed are limited to stock on hand. Contact Tolomatic regarding availability.

Loctite® is a registered trademark of the Loctite Corporation, www.loctite.com

Magnalube®-G is a registered trademark of the Carleton-Stuart Corporation, www.magnalube-g.com

SWITCH TYPE CODE	
BT	(Form C Reed Switch with 5-meter lead)
BM	(Form C Reed Switch with 5-meter lead and QD)
RT	(Form A Reed Switch with 5-meter lead)
RM	(Form A Reed Switch with 5-meter lead and QD)
CT	(TRIAC Switch with 5-meter lead)
CM	(TRIAC Switch with 5-meter lead and QD)
KT	(Hall-effect Switch (Sinking) 5-meter lead)
KM	(Hall-effect Switch (Sinking) 5-meter lead and QD)
TT	(Hall-effect Switch (Sourcing) 5-meter lead)
TM	(Hall-effect Switch (Sourcing) 5-meter lead and QD)

UNIVERSAL SWITCH WIRING DIAGRAMS AND LABEL COLOR CODING

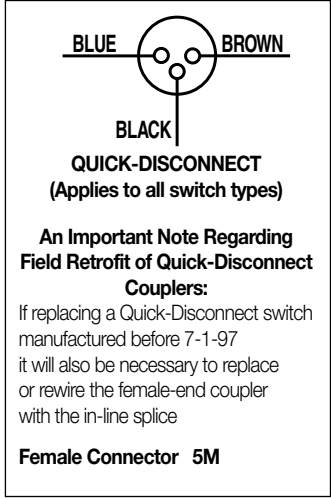
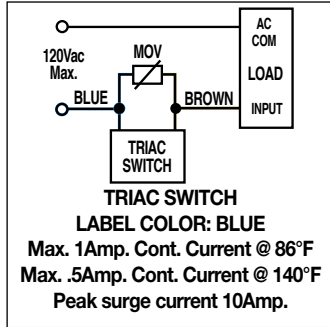
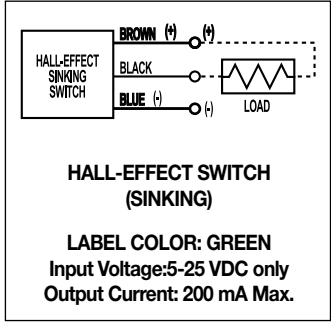
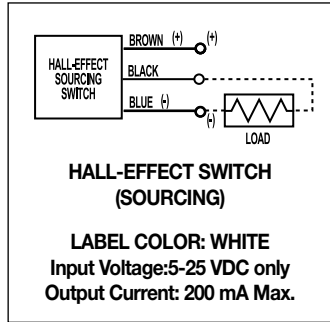
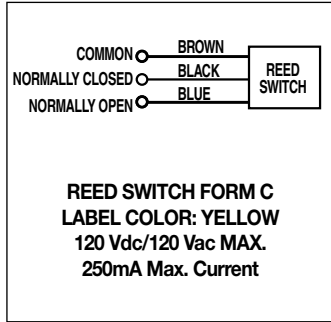
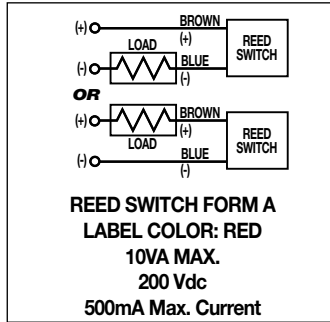

NOTE: The side of the switch with the groove indicates the sensing surface. This must face toward the magnet.

For complete Switch Performance Data, refer to the Tolomatic Fluid Power Products Catalog 9900-4000



3800 County Road 116, Hamel, MN 55340 USA
 http://www.Tolomatic.com • Email: Help@Tolomatic.com
 Phone: (763) 478-8000 • Fax: (763) 478-8080 • Toll Free: 1-800-328-2174

COMPANY WITH QUALITY SYSTEM CERTIFIED BY DNV = ISO 9001 =

All brand and product names are trademarks or registered trademarks of their respective owners. Information in this document is believed accurate at time of printing. However, Tolomatic assumes no responsibility for its use or for any errors that may appear in this document. Tolomatic reserves the right to change the design or operation of the equipment described herein and any associated motion products without notice. Information in this document is subject to change without notice.