

BC2 Series™ Band Cylinder®

BC205/BC2M05

1/2" (12 mm) Bore

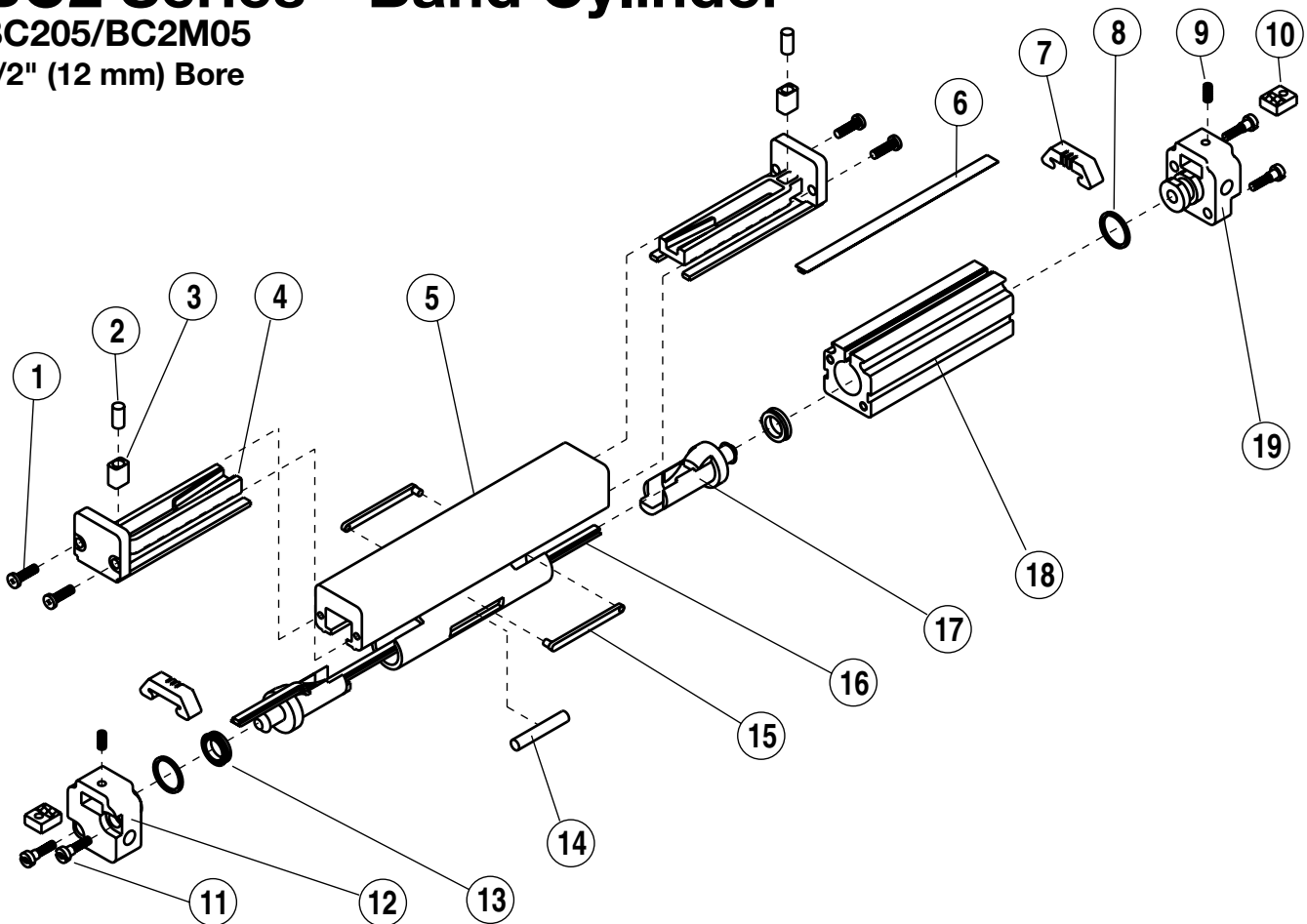

Parts Listing

| ITEM | PART NO. or CONFIG. CODE | DESCRIPTION | QTY. | |
|------------------|--------------------------|--------------------------------------|---------------------|---------------|
| | | | BC205 U.S. Standard | BC2M05 Metric |
| 1 | 0905-1117 | Screw | 4 | - |
| | 4505-1002 | | - | 4 |
| 2 ³ | 4510-1014 | Spring | 2 | |
| 3 ³ | 0605-1013 | Band Insert | 2 | |
| 4 ³ | 0905-1110 | End Cap/Band Ramp | 2 | |
| 5 | 0905-1113 | Piston Bracket/Carrier | 1 | - |
| | 4505-1003 | | - | 1 |
| 6 ^{3,4} | NDBBC205 | Replacement Dust Band specify stroke | A/R | - |
| | NDBBC2M05 | | - | A/R |
| 7 ³ | 0905-1033 | Shock Absorbing Pad | 2 | |
| 8 ³ | 0905-1005 | O-Ring | 2 | |
| 9 | 0905-1007 | Set Screw | 2 | |
| 10 | 0905-1008 | Band Clamp | 2 | |

| ITEM | PART NO. or CONFIG. CODE | DESCRIPTION | QTY. | |
|-------------------|--------------------------|--------------------------------------|---------------------|---------------|
| | | | BC205 U.S. Standard | BC2M05 Metric |
| 11 | 0505-1000 | Tapped Screw | 4 | - |
| | 4505-1000 | | - | 4 |
| 12 | 0905-1001 | Left Head | 1 | - |
| | 4905-1001 | | - | 1 |
| 13 ³ | 0905-1015 | U-Cup | 2 | |
| 14 | 0905-1171 | Magnet | 1 | |
| 15 ³ | 0905-1114 | Bearing | 2 | |
| 16 ^{3,4} | NSBBC205 | Replacement Seal Band specify stroke | A/R | - |
| | NSBBC2M05 | | - | A/R |
| 17 | 0905-1111 | Piston End | 2 | |
| 18 ⁴ | RTBBC205 | Replacement Tube specify stroke | A/R | - |
| | RTBBC2M05 | | - | A/R |
| 19 | 0905-1004 | Right Head | 1 | - |
| | 4905-1004 | | - | 1 |

COMMON REPLACEMENT PARTS:

3 Repair Kit: Parts contained in Repair Kit RKBC2(M)05SK_ _ _

4 After configuration code add: SK_ _ _ (note: the letters SK indicate stroke, follow these letters with the stroke length in decimal inches.)

MAINTENANCE

1. The Band Cylinder® should be kept as clean as possible around the bands and Carrier Bracket.
2. Always use air that is adequately lubricated. Tolomatic recommends that a 5 to 10 weight non-detergent, petroleum oil be used. For FDA requirements, we recommend that Multitherm® PG-1 or equivalent be used. For dry air applications, please consult Tolomatic, Inc., toll free at 1-800-328-2174.

DISASSEMBLY INSTRUCTIONS

1. With a razor blade, remove Shock Absorbing Pads and excess glue from face of cylinder Heads. Remove Set Screws (9) from Heads (12, 19) and dislodge Band Wedges (10) from Head slots. Remove the Head Screws (11) and remove Heads.
2. Slide the Piston Carrier Bracket (5) to one end of the Tube and remove the End Cap Screws (1). Hold a finger over the top of the End Cap to contain the Spring (2) while pulling on the End Cap Band Ramp (4) assembly to remove it. Slide Piston Carrier Bracket to opposite end of Tube and remove other End Cap Band Ramp assembly in same manner. Slide Piston out Tube. Remove Piston Ends (17) from the Piston Carrier Bracket (being careful not to damage the ends) Remove U-Cups (13).
3. Remove the Dust Band (6) and collapse Sealing Band (16) by pressing down on it lightly with an O-ring pick or similar tool, gliding the pick the length of the cylinder tube.

ASSEMBLY INSTRUCTIONS

1. **CLEAN AND LUBRICATE:** Thoroughly clean all components, particularly the tube bore slot and bands. **Generously lubricate the tube and all rubber parts including the rubber on both the Sealing and Dust Band with Magnalube®-G grease.**
2. **INSTALL CARRIER AND BEARINGS:** Snap Bearings (15) into slots on the Piston Bracket Carrier (5). Slide assembly into Tube (18). If there is any interference between the Bearings and the Tube slot, lightly sand Bearings with 30 micron mylar sandpaper to remove any interference.
3. **PREPARE AND INSERT INSIDE SEALING BAND AND PISTON ENDS:** Clean the Sealing Band (16) thoroughly and remove any residue from the stainless steel surface with a razor blade.

CAUTION: Sealing Band is sharp and may cause serious injury. Handle with care! Sharp edges of band are easily damaged.

CAREFULLY check band for nicks or burred edges. If present, remove by sanding beveled side with 320 emery cloth and the top side (side with retaining rubber) with 30 micron mylar sandpaper. Fill grooves on both sides of rubber strip with Magnalube-G grease. Weave one end of Sealing Band (16) through one Piston End (17). Feed Sealing Band through hole in Piston on Piston Bracket/Carrier (5) and snap Piston End (17) into Piston Bracket/Carrier (5). Weave other end of Sealing Band through other Piston End (17) and snap Piston End into place on other end of Piston Bracket/Carrier. Insert U-Cups (13) onto Piston Ends

4. **INSTALL PISTON BRACKET/CARRIER ASSEMBLY:** Generously lubricate bore and slot of Tube (18) and bearing portion of Piston Bracket/Carrier (5) with grease. Insert Piston Bracket/Carrier (5) into greased end of Tube (18) guiding Sealing Band through Tube. Push Piston Bracket/Carrier assembly along the Tube to seat the Sealing Band into its groove and disperse grease the length of the Tube. Remove excess grease from end of cylinder. With a razor blade, trim off rubber on Sealing Band (16) flush

with end of Tube closest to the Piston. With tin snips, trim metal band to .437" from rubber (tolerance of +/- .032").

5. **INSTALL HEAD:** Install O-Ring (8) into groove in Head (12). On end of Tube with trimmed Sealing Band, install Head (12) with a gentle rocking motion and secure with the two Tapped Screws (11).

CAUTION: Do NOT twist Head when installing. A cut O-Ring may result causing air leakage during operation. Do NOT cut Band longer than the Head thickness or serious injury may occur during installation.

6. **INSTALL DUST BAND:** Thoroughly clean Dust Band (6) and fill both grooves of rubber strip with grease. Weave Dust Band (6) through End Cap/Band Ramp (4). Slide this assembly through hole in Carrier portion of Piston Bracket/Carrier (5). Before seating the End Cap/Band Ramp (4) flush to the Carrier, place Band Insert (3) and Spring (2) into position on End Cap/Band Ramp (4). Repeat these same procedures for other end of Dust Band (6).

Apply Loctite® #222 on screws (1) and secure End Cap/Band Ramps (4) to Piston Bracket/Carrier (5).

7. **TRIM DUST BAND AND INSTALL BAND CLAMP:** With razor blade, trim rubber on end of Dust Band (6) flush with Head (12). With tin snips, trim steel portion of Band so end is just short of through hole in top of Head. Insert Dust Band into slot in Head. Insert Band Clamp (10) into slot on Head, fitting it between Sealing Band (16) and Dust Band (6). Insert Set Screw (9) into hole in top of Head (12). Apply Loctite® #222 and thread Set Screw (9) into Band Clamp (10) until it tightens firmly against bottom band.
8. **INSTALL SECOND HEAD:** Slide Carrier to opposite end of Tube (18). Trim Sealing Band (16) as indicated in step 4. Install second Head (19) and secure with two Tapped Screws (11) and Loctite® #222. Trim and insert Dust Band (6), Band Clamp (10) and secure as indicated in step 7.
9. **INSTALL SHOCK ABSORBING PAD:** Clean the exposed top face of the Head (19) with contact cleaner, avoiding excess cleaner contacting the Dust Band (6). Using Loctite #495, glue a Shock Absorbing Pad (7) to face of each Head (12 and 19).

10. CHECK ASSEMBLY AND REMOUNT**OPTIONAL ACCESSORY ASSEMBLY INSTRUCTIONS****1. TUBE SUPPORTS**

Follow cylinder assembly instructions through steps 4. Before installing second cylinder Head (19) in step 5., slide Tube Support (23) onto cylinder Tube (18).

2. FOOT MOUNTS

On assembled cylinder, insert Screws (29) through holes in Foot Mount Bracket (30) and install in holes on cylinder Heads (12,19).

3. FLOATING MOUNT

Completely assemble cylinder. Attach Floating Plate (20) to Carrier (5) with Screws (22) and Loctite® #242. Place Floating Mount Bracket (33) over pin of Floating Plate (20) and hold in place with a rubber band.

4. SWITCHES

On assembled cylinder, Secure Switch to open port side of cylinder with Switch Hardware Kit. Cycle the carrier over the Switch by hand to ensure that the carrier does not hit the switch.

See page 3 and 4 for additional switch information

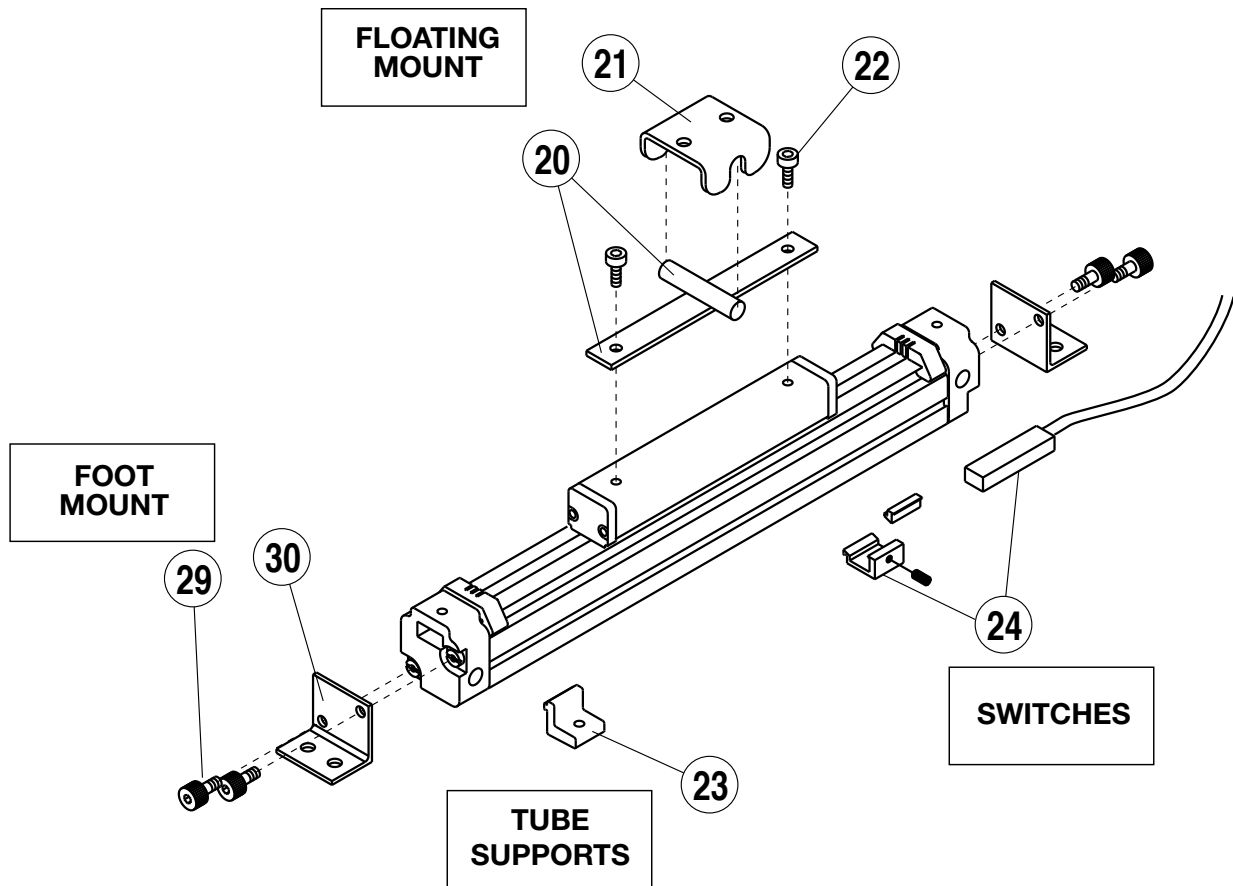

| ITEM | PART NO. | DESCRIPTION | QTY. | |
|----------------------------------|-----------|----------------------------|------------------------|------------------|
| | | | BC205 U.S. Standard | BC2M05 Metric |
| FLOATING MOUNT | | | | |
| KIT | 0905-9115 | Floating Mount Bracket Kit | 1 | – |
| | 4905-9115 | | – | 1 |
| 20 | 0905-1026 | Floating Plate | 1 | 1 |
| 21 | 0905-1027 | Floating Bracket | 1 | 1 |
| 22 | 0605-1045 | Screw | 2 | – |
| | 4905-1005 | | – | 2 |
| TUBE SUPPORTS⁴ | | | | |
| 23 ⁴ | 0905-1034 | Tube Support Bracket | 2 | 2 |
| FOOT MOUNT¹ | | | | |
| KIT ¹ | 0905-9010 | Foot Mount Kit | 1 | – |
| | 4905-9010 | | – | 1 |
| 29 | 0905-1038 | Screw | 4 | – |
| | 4905-1006 | | – | 4 |
| 30 | 0905-1037 | Bracket | 2 | 2 |

| ITEM | PART NO. | DESCRIPTION | QTY. | |
|---|--------------------------------------|--------------------|------------------------|------------------|
| | | | BC205 U.S. Standard | BC2M05 Metric |
| SWITCHES | | | | |
| CONFIG. CODE ORDERING | | | | |
| Mounting Hardware & FE conn. included | | | | |
| | | DESCRIPTION | CODE | |
| 24 | Switch Kit, Reed, Form C, 5m | | BT | |
| | Switch kit, Reed, Form C, Male Conn. | | BM | |
| | Switch kit, Reed, Form A, 5m | | RT | |
| | Switch kit, Reed, Form A, Male Conn. | | RM | |
| | Switch kit, Triac, 5m | | CT | |
| | Switch kit, Triac, Male Conn. | | CM | |
| NOTE: When kit is ordered female connector & all mounting hardware is included. | | | | |
| | 0905-1171 | Switch Magnet | 1 | 1 |

Service Parts Ordering NOTES:

1 Foot Mount Kit contains two foot mount brackets and mounting hardware

4 A minimum of 2 (two) Tube Supports required per cylinder

NA = Not Available

Switch Ordering NOTES:

To order field retrofit switch and hardware kits for all Tolomatic actuators: SW (Then the model and bore size, and type of switch required)

Example: SWBC205RT

(Hardware and Form A Reed switch with 5 meter lead for 0.5" bore BC2 band cylinder)

WIRING DIAGRAMS

RT & RM DC REED, FORM A

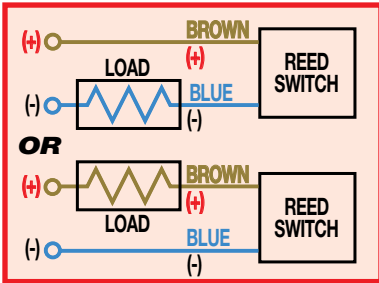

CT & CM AC REED, TRIAC

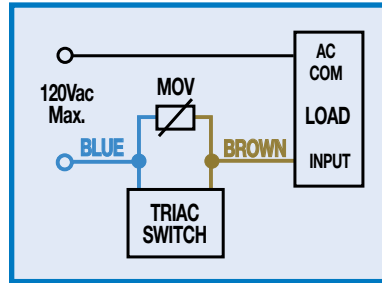

BT & BM DC REED, FORM C

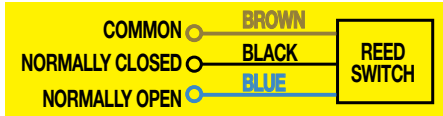

INSTALLATION INFORMATION



⚠ THE NOTCHED FACE OF THE SWITCH INDICATES THE SENSING SURFACE AND MUST FACE TOWARD THE MAGNET.

Some actuators may require switch mounting on a specific side of the assembly. Call Tolomatic for details.

⚠ REPLACEMENT OF QD SWITCHES MANUFACTURED BEFORE JULY 1, 1997: It will be necessary to replace or rewire the female end coupler.



Female Connector 5M

SWITCH OPTION

NOTE: Form A Reed Switches should not be used in TTL logic circuits. A voltage drop caused by the L.E.D. indicator will result. For applications where TTL circuits are used, please contact the factory.

WARNING: An ohmmeter is recommended for testing Reed Switches. NEVER use an incandescent light bulb as a high current rush may damage the switch.

Reed and TRIAC switches are only recommended for signalling position, not directly powering solenoids. For shifting a solenoid, a relay or resistor is recommended between it and the Reed Switch. Switch ratings must not be exceeded at any time.

For complete Switch Performance Data, refer to the Tolomatic Fluid Power Products Catalog # 9900-4000.

MAINTENANCE

The Band Cylinder® should be kept as clean as possible around the bands and Carrier Bracket.

LUBRICATION

All Tolomatic Band Cylinders are pre-lubricated at the factory. To ensure maximum cylinder life, the following guidelines should be followed.

- 1. Filtration-** We recommend the use of dry, filtered air in our products. 'Filtered air' means a level of 10 Micron or less. 'Dry' means air should be free of appreciable amounts of moisture. Regular maintenance of installed filters will generally keep excess moisture in check.
- 2. External Lubricators (optional)-** The factory pre-lubrication of Tolomatic Band Cylinders will provide optimal performance without the use of external lubrication. However, external lubricators can further extend service life of pneumatic actuators if the supply is kept constant.

Oil lubricators, (mist or drop) should supply a minimum of 1 drop per 20 standard cubic feet per minute to the cylinder. As a rule of thumb, double that rate if water in the system is suspected. Demanding conditions may require more lubricant.

If lubricators are used, we recommend a **non-detergent, 20cP @ 140°F 10-weight lubricant**. Optimum conditions for standard cylinder operation is +32° to +125°F (+0° to 51.6°C).

NOTE: Use of external lubricators will wash away the factory installed lubrication. External lubricants *must be maintained* in a constant supply or the results will be a dry actuator prone to failure.

- 3. Sanitary environments-** Oil mist lubricators must dispense 'Food Grade' lubricants to the air supply. Use fluids with **ORAL LD₅₀ toxicity ratings of 35 or higher such as Multitherm® PG-1 or equivalent**. Demanding conditions can require a review of the application.

Band Cylinder® is a registered trademark of Tolomatic, Inc.
 Loctite® is a registered trademark of the Loctite Corporation, www.loctite.com
 Magnalube®-G is a registered trademark of the Carleton-Stuart Corporation, www.magnalube-g.com



3800 County Road 116, Hamel, MN 55340
 http://www.Tolomatic.com • Email: Help@Tolomatic.com
 Phone: (763) 478-8000 • Fax: (763) 478-8080 • Toll Free: 1-800-328-2174



Information furnished is believed to be accurate and reliable. However, Tolomatic assumes no responsibility for its use or for any errors that may appear in this document. Tolomatic reserves the right to change the design or operation of the equipment described herein and any associated motion products without notice. Information in this document is subject to change without notice.